

Process Manual

Technical guidelines for the insulation
of industrial installations



ProRox®

Industrial
insulation

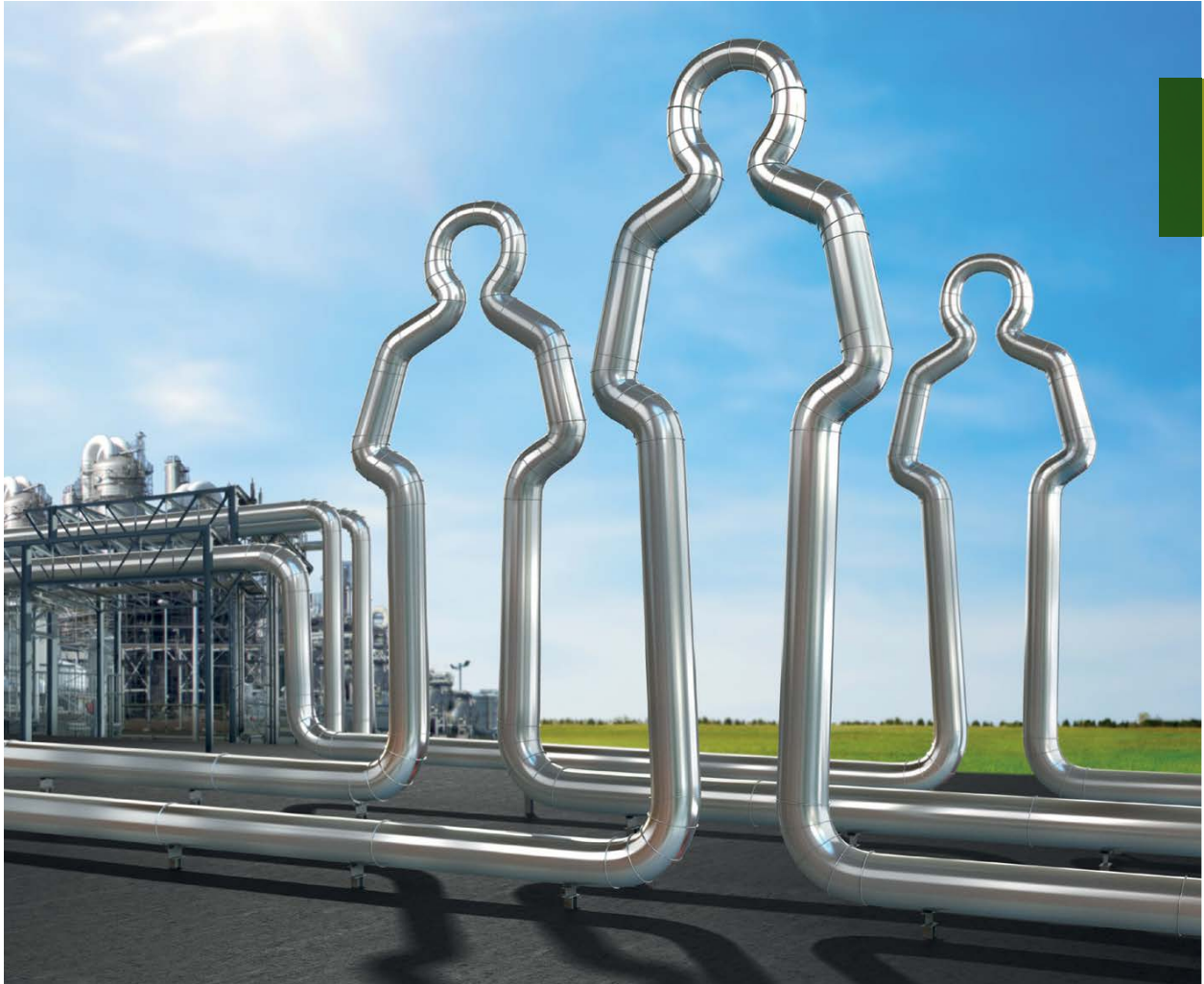

Discover Rockassist[®],
the thermal calculation tool
at rti.rockwool.com

Rockassist

is an online calculation program for calculating the ideal insulation thickness, maximise operational energy efficiency and thus reduce energy costs and CO₂ emissions.

EXPERT TOOL



Overview ROCKWOOL Technical Insulation system solutions

1.2 Insulation of piping 25

1.2.1 Insulation with ProRox mandrel wound pipe sections 32

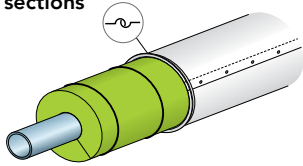

1.2.2 Insulation with ProRox load-bearing mats (wrap) 32

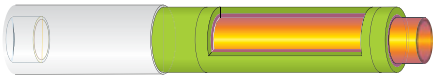

1.2.3 Insulation with ProRox wired mats 36

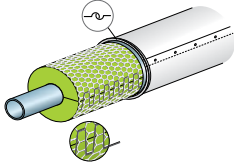

1.2.4 Insulation support 38

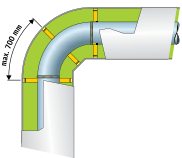

1.2.5 Cladding (jacketing) 40



1.2.6 Pipe hangers and pipe support 43

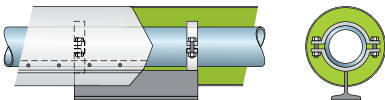

1.2.7 Insulation of valves and flanges 44

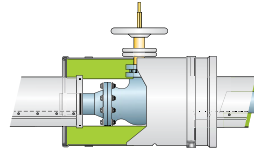

1.2.8 Insulation of pipe elbows and T pieces 46

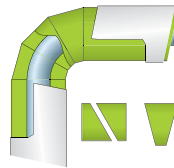

1.2.9 Reducers 47

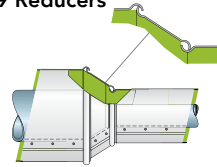

1.2.10 Expansion joints 48

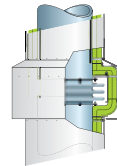

1.2.11 Tracing 49

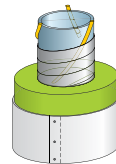

1.2.12 Foot traffic 50

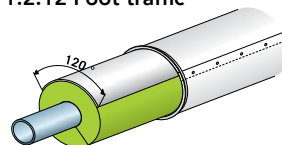

1.3 Insulation of vessels 55

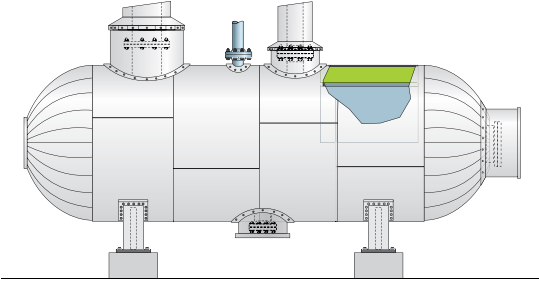

1.4 Insulation of columns 61

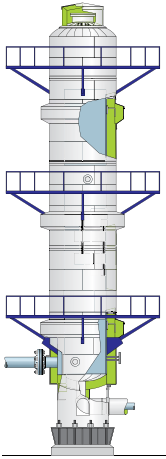

1.5 Insulation of storage tanks 67

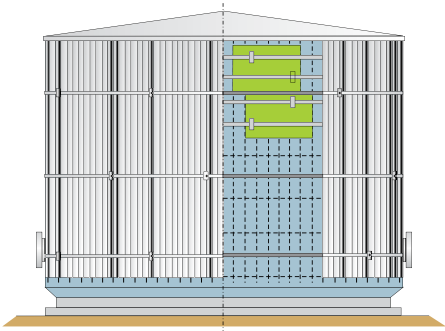

1.6 Insulation of boilers 75

1.6.1 Insulation of fire tube boilers 75

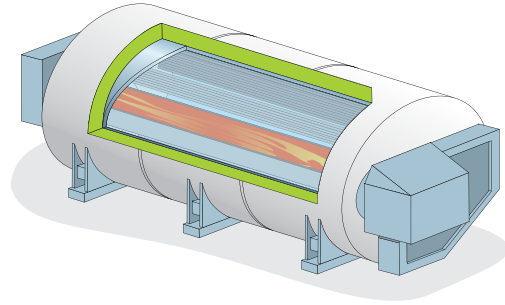

1.6.2 Supercritical steam generators 77

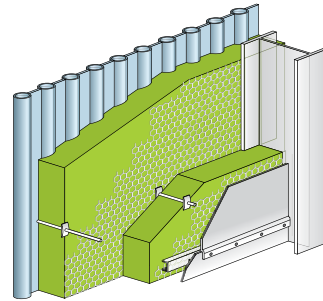

1.7 Insulation of flue gas ducts 83

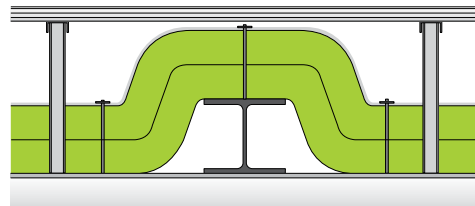

1.8 Cold boxes 90

Contents

9

1. System solutions

1.1 Planning and preparation	11
1.2 Insulation of piping	25
1.3 Insulation of vessels	55
1.4 Insulation of columns	61
1.5 Insulation of storage tanks	67
1.6 Insulation of boilers	75
1.7 Insulation of flue gas ducts	83
1.8 Cold boxes	90

93

2. Theory

2.1 Norms & Standards	96
2.2 Product properties & test methods	118
2.3 Bases for thermal calculations	131

139

3. Tables

3.1 Units, conversion factors and tables	142
3.2 Product properties insulation and cladding materials	158
3.3 Usage tables	163

181

4. Products

4.1 Products: Europe, Middle-East & Africa	186
4.2 Products: North America	195



Dear customer,

ROCKWOOL® Technical Insulation is a known entity in the insulation market. Specialists such as yourself often willingly turn to our products and expertise in industrial and marine & offshore insulation (with ProRox® & SeaRox® product lines). We have now packaged that expertise into a practical guide: the 'Industrial Insulation Process Manual'.

This new manual offers a transparent overview of our ProRox product range, including our thermal, fire-resistant and acoustic insulation solutions for technical installations in the process & power generation industries.

The Process Manual is a handy and compact expert tool which is very convenient to consult. Fold-out sections take you straight to the right page, whether you are looking for straightforward piping insulation or for more complex applications for columns, tanks and boilers. In addition to the many pictures and photographs, a whole range of tables and diagrams clarify the information provided.

Keep this manual close by. It is a helpful tool for the application of our ProRox insulation solutions in a process environment. Should you need any further information about a specific application, procedure or practical problem, please consult rti.rockwool.com or contact your local ROCKWOOL Technical Insulation representative.

John Mogensen
ROCKWOOL Technical Insulation
Managing Director



European Industrial
Insulation Foundation

Founding Partner

www.eiif.org

Founding partner of EIIIF

ROCKWOOL Technical Insulation was one of the founding partners of the European Industrial Insulation Foundation (EIIIF), which has established itself as a resource for industries that need to reduce CO₂ emissions.



We share our knowledge to your advantage

ROCKWOOL Technical Insulation – a subsidiary of the ROCKWOOL Group – develops innovative technical insulation solutions for the process industry and the shipbuilding & offshore markets. Through our comprehensive product lines ProRox and SeaRox we offer a full spread of sustainable products and systems guaranteeing the highest possible protection of all technical installations against heat and energy loss, fire, noise and other unwanted influences.

Our +80 years of experience are reflected in a complete set of high-grade products and expert advice. Today, our dedicated and technically experienced people remain fully committed to providing the very best service and tools in the market and a total range of cutting-edge insulation solutions. Besides excellent insulation products,

they are the real key to our success. Thanks to their expertise and extensive experience, we can offer end users in the petrochemicals, power generation, shipbuilding, offshore and the process industries solid stone wool insulation solutions, expert tools and an impeccable service - all shaped to fit everyone's needs.

Industrial insulation

shaped by experts.

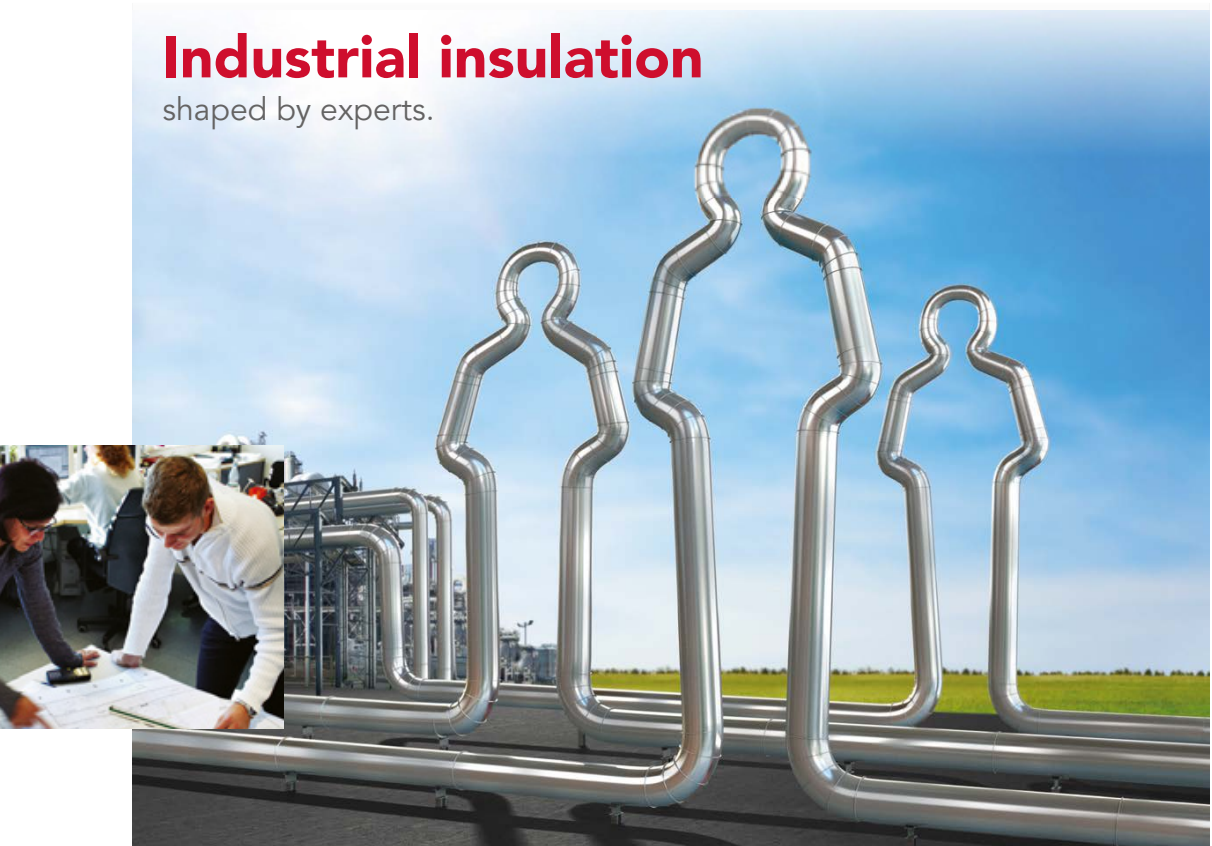

The ROCKWOOL Technical Insulation Process Manual

Know-how for designers, engineers, site supervisors and managers of industrial plants

Energy keeps the world in motion. Without it, everything would come to a standstill. The global economy is dependent upon a secure, efficient supply of energy. Over eighty percent of the energy currently being consumed however is obtained from non-renewable resources. And those resources are becoming increasingly scarce, whilst at the same time the demand for energy is exploding. This means that owners, designers and operators of large, industrial plants are challenged with the task of reducing their energy consumption as much as possible in order to ensure the long term sustainability of their operations.

Solar energy is just one of the possible alternatives. Through, for example, solar power plants we already succeed in converting concentrated sunlight very efficiently into electricity. And this is just one of the solutions that can help us drive down fuel consumption and carbon emissions.

On top of that, insulation significantly reduces the energy needed to manufacture a product or provide a service. Nowadays there are a great many efficient insulation systems that enable scarce energy reserves to be put to the best possible use. The ROCKWOOL Technical

Insulation Process Manual illustrates these systems both theoretically and practically. This process manual targets designers, installers and managers of industrial plants and provides them an overview of the possible modern insulation techniques for, by way of example, chemical or petrochemical installations and power stations. Based on current standards and regulations the manual provides accessible, practical guidelines for the implementation of numerous insulation applications.

Restriction of thermal losses to an absolute minimum, including during transfer or storage, can considerably reduce the energy consumption of industrial plants. This also results in a reduction in carbon dioxide (CO₂) emissions, which are created each time fossil fuels such as coal or gas are burnt and which, as a greenhouse gas, is responsible for the global increase in temperature.

From an environmental perspective, adequate insulation of industrial plants is a significant means of reducing (CO₂) emissions. This measure pays off in two ways, because within the framework of the EU Emission Trading Scheme, CO₂ reduction equally signifies a reduction in emission costs.

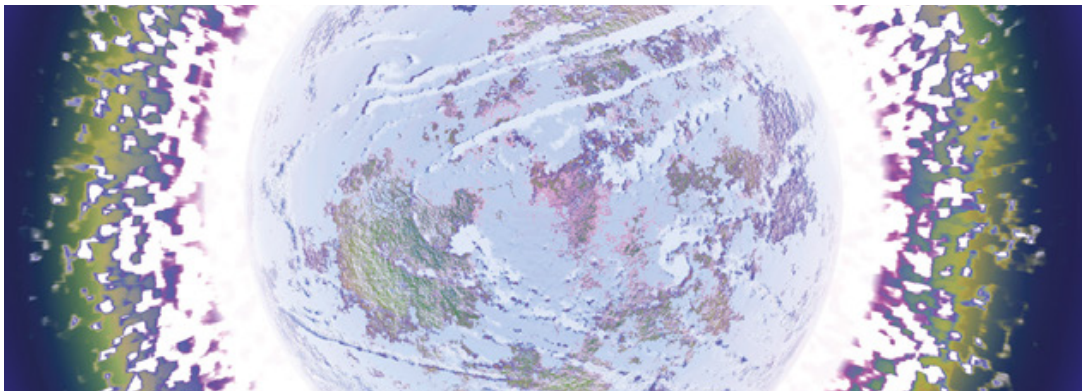

In addition, the right insulation keeps temperatures, for example in pipes and storage tanks, within strict tolerances, thereby ensuring reliable process efficiency. At the same time, adequate insulation protects the plant itself. Modern insulating materials can thoroughly protect plant components from moisture and associated corrosion. Installation and process maintenance costs can be reduced considerably and the effective lifetime of industrial plants can be successfully maximised.

Furthermore, industrial insulation also provides a significant contribution to personal protection. Optimum insulation reduces process temperatures and noise in the industrial environment to an acceptable level, to the limits generally regarded in the industry to be those required for a safe and comfortable working environment.

With a complete range of techniques and insulation systems, ROCKWOOL Technical Insulation offers designers and construction supervisors optimum tailored solutions for the petrochemical, energy, ship building, offshore and processing industries.



Process Manual

In the 'Flow of Energy' diagram on the following page, you will find an overview of all of the sectors in which we are active, like the process industry and marine & offshore. All of our ProRox (and SeaRox) products, such as mandrel wound pipe sections, slabs (board), wired mats and lamella mats (wrap), as well as loose insulating wool, fulfil the highest quality and safety standards and comply with the strictest, and therefore safest, fire safety classes. Stone wool is non-flammable up to temperatures of approximately 1830°F (1000°C) and therefore provides a crucial contribution towards passive fire protection.

As a supplement to this process manual, ROCKWOOL Technical Insulation also regularly provides information about technical innovations, product solutions and recent and relevant documents available online at our website rti.rockwool.com. The process manual is a guideline and can only provide general advice for specific instances in the field of plant and processes. For these instances, ROCKWOOL Technical Insulation's experts are available to provide advice during the design, engineering and implementation phases.



ROCKWOOL Technical Insulation, Flow Of Energy >

ROCKWOOL Technical Insulation, flow of energy

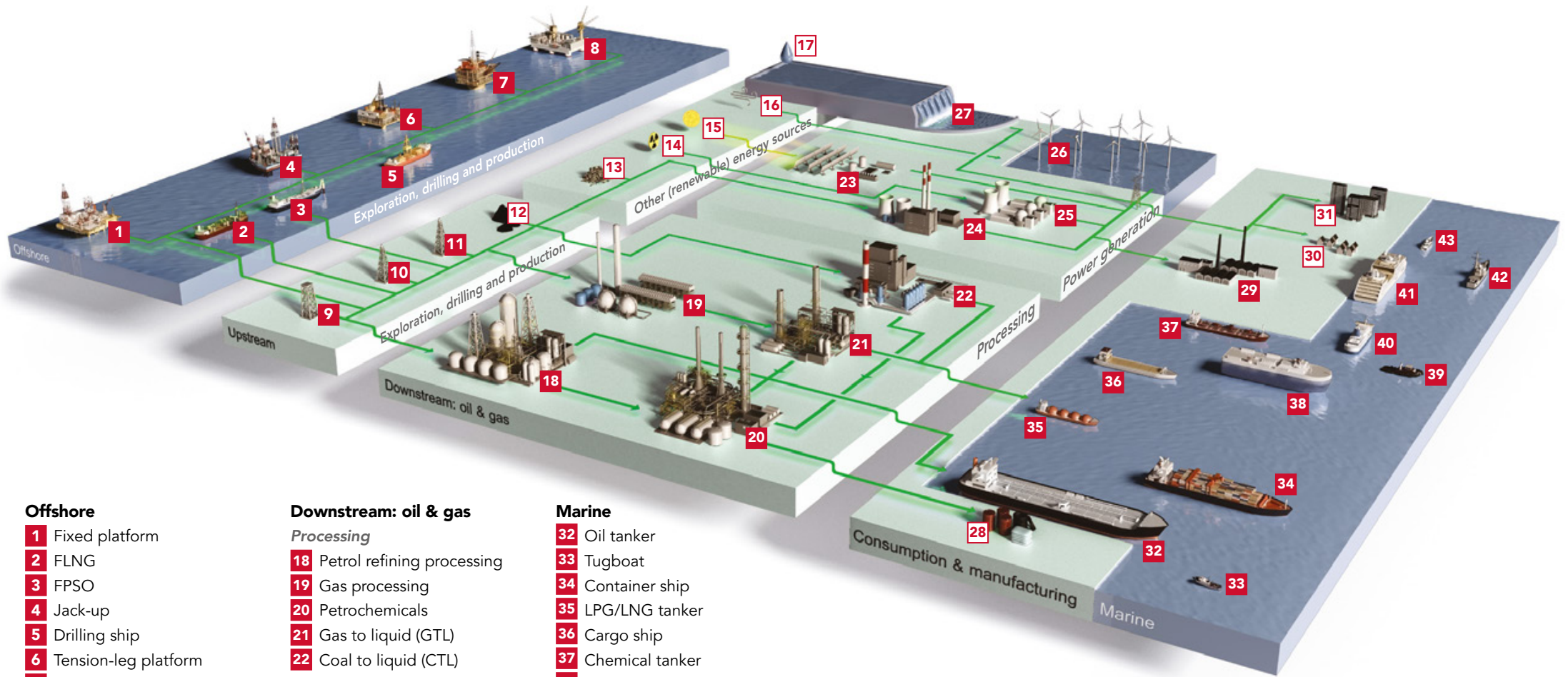

- Offshore**
- 1 Fixed platform
 - 2 FLNG
 - 3 FPSO
 - 4 Jack-up
 - 5 Drilling ship
 - 6 Tension-leg platform
 - 7 Spar
 - 8 SSST – (AU/DR/FPU)

- Upstream**
- 9 Oil
 - 10 Shale gas
 - 11 Natural gas
 - 12 Coal

- Other energy sources**
- 13 Waste
 - 14 Plutonium
 - 15 Sun
 - 16 Windpower
 - 17 Hydropower

- Downstream: oil & gas**
- Processing*
- 18 Petrol refining processing
 - 19 Gas processing
 - 20 Petrochemicals
 - 21 Gas to liquid (GTL)
 - 22 Coal to liquid (CTL)
- Power generation**
- 23 Solar power plant
 - 24 Conventional power generation
 - 25 Nuclear power generation
 - 26 Windfarm
 - 27 Hydropower station

- Consumption & manufacturing**
- 28 End products
 - 29 Manufacturing
 - 30 Residential
 - 31 Non-residential

- Marine**
- 32 Oil tanker
 - 33 Tugboat
 - 34 Container ship
 - 35 LPG/LNG tanker
 - 36 Cargo ship
 - 37 Chemical tanker
 - 38 Ro-Ro ship
 - 39 Fishing boat
 - 40 Ferry
 - 41 Cruiser/Passenger ship
 - 42 Military ship
 - 43 Yacht

■ Areas & industries where our technical insulation products are used.

□ Others

ProRox® ProRox insulation: Our ProRox product line covers all our thermal, fire-resistant and acoustic insulation solutions for technical installations in the process and in offshore industries.

SeaRox® SeaRox insulation: SeaRox comprises the full marine and offshore product line. This sharp focus enables us to combine our expertise and extensive experience like never before to develop outstanding insulation solutions for our customers.



1

System solutions

ProRox[®]

Industrial
insulation

1. System solutions

Table of contents

1.1 Planning and preparation	11
1.1.1 Decision criteria for the design of an insulation system	11
A. Functional requirements	12
B. Safety aspects	16
C. Economics	17
D. Environmental	18
E. Corrosion mitigation	18
1.1.2 Design & planning of the insulation work	19
1.1.3 Corrosion mitigation	19
1.1.4 Storage of insulation materials	23
1.2 Insulation of piping	25
1.2.1 Insulation with ProRox mandrel wound pipe sections	32
1.2.2 Insulation with ProRox load-bearing mats (wrap)	34
1.2.3 Insulation with ProRox wired mats	36
1.2.4 Insulation support	38
1.2.5 Cladding (jacketing)	40
1.2.6 Pipe hangers and pipe supports	43
1.2.7 Insulation of valves and flanges	44
1.2.8 Insulation of pipe elbows and T pieces	46
1.2.9 Reducers	47
1.2.10 Expansion joints	48
1.2.11 Tracing	49
1.2.12 Foot traffic	50
1.2.13 Non contact insulation for CUI (Corrosion under insulation) mitigation	50
1.2.14 Acoustic solutions	51
1.3 Insulation of vessels	55
1.4 Insulation of columns	61
1.5 Insulation of storage tanks	67
1.6 Insulation of boilers	75
1.6.1 Insulation of fire tube boilers	75
1.6.2 Supercritical steam generators	77
1.7 Insulation of flue gas ducts	83
1.7.1 Installation of the insulation systems for flue gas ducts	83
1.7.2 Cladding (jacketing) of flue gas ducts	86
1.7.3 Acoustic insulation of flue gas ducts	89
1.8 Cold boxes	90

1. System solutions

1.1 Planning and preparation

The design of a suitable insulation system for technical installations is a major factor for its economical operation, functionality, security, durability and environmental impact. Additionally, the installation-specific heat losses are specified for the entire life cycle of the plant. Corrections at a later stage, such as subsequently increasing the thickness of the insulation, for example, may no longer be possible due to lack of space. Corrections at a later stage may also entail a far greater investment compared to the original planning. Continually rising energy costs are also often overlooked factors when dimensioning the insulation. Insulation thicknesses that are designed to last take energy price increases into account. They form an important criterion for the economical operation of the installation after just a few years.

We have an obligation to future generations to treat our environment with care. Correctly dimensioned insulation systems constitute an important contribution to environmental protection, carbon dioxide (CO₂) reduction and to economic success, because: CO₂ reduction is also an economical operation, as it lowers the costs for CO₂ emission certificates.

Nowadays, conservational and economical operations are no longer conflicting ideas, but on the contrary, they are two inseparable parameters.

1.1.1. Decision criteria for the design of an insulation system

Selecting a suitable insulation system depends on the following four parameters:

- **A. Functional requirements**
 - a. Object dimensions
 - b. Operation of the installation
 - c. Operating temperatures
 - d. Permissible heat losses or temperature changes of the medium
 - e. Frost protection
 - f. Ambient conditions
 - g. Maintenance and inspection
- **B. Safety aspects**
 - a. Personal protection
 - b. Fire protection
 - c. Explosion prevention
 - d. Noise reduction within the plant
- **C. Economics**
 - a. Economical insulation thickness
 - b. Pay-back time
- **D. Environment**
- **E. Corrosion prevention**

1.1 Planning and preparation

A. Functional requirements

a) Object dimensions

The space requirements of the insulation must be taken into account when the installation is being designed and planned. Therefore, the insulation thicknesses should be determined in the early planning stages and the distances between the individual objects should be taken into account in the piping isometrics. To guarantee systematic installation of the insulation materials and the cladding (jacketing) without increased expense, observe the minimum distances between the objects as specified in the following illustrations.

If nothing else is specified or local experience/practice does not exist, use the following minimum distances provided by DIN 4140 for onshore applications as a guide.

Minimum distances between vessels and columns in accordance with DIN 4140; dimensions in inches (mm)

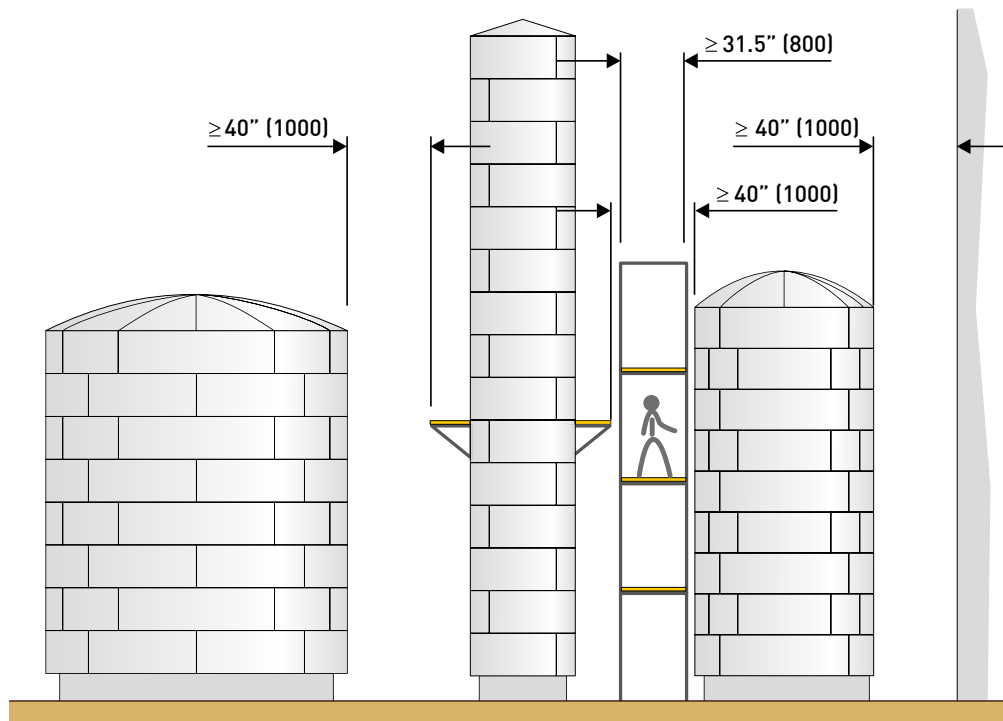

Minimum distances between insulated pipes in accordance with DIN 4140; dimensions in inches (mm)

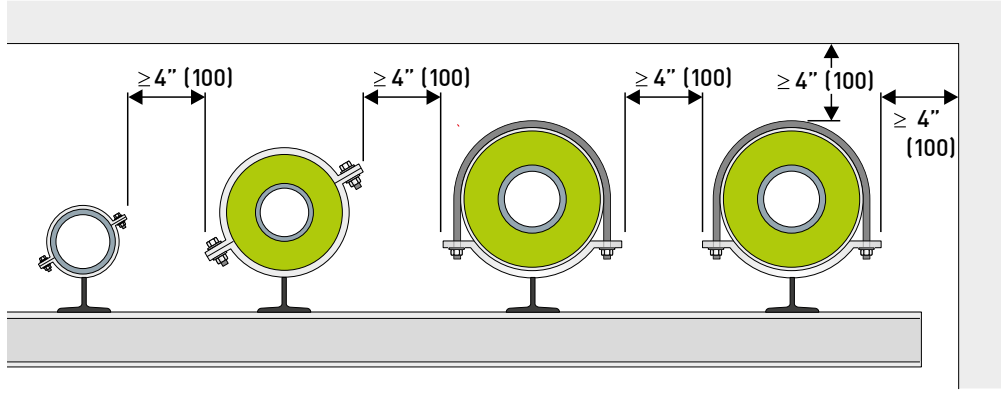

Minimum distances within range of pipe flanges in accordance with DIN 4140; dimensions in inches (mm)

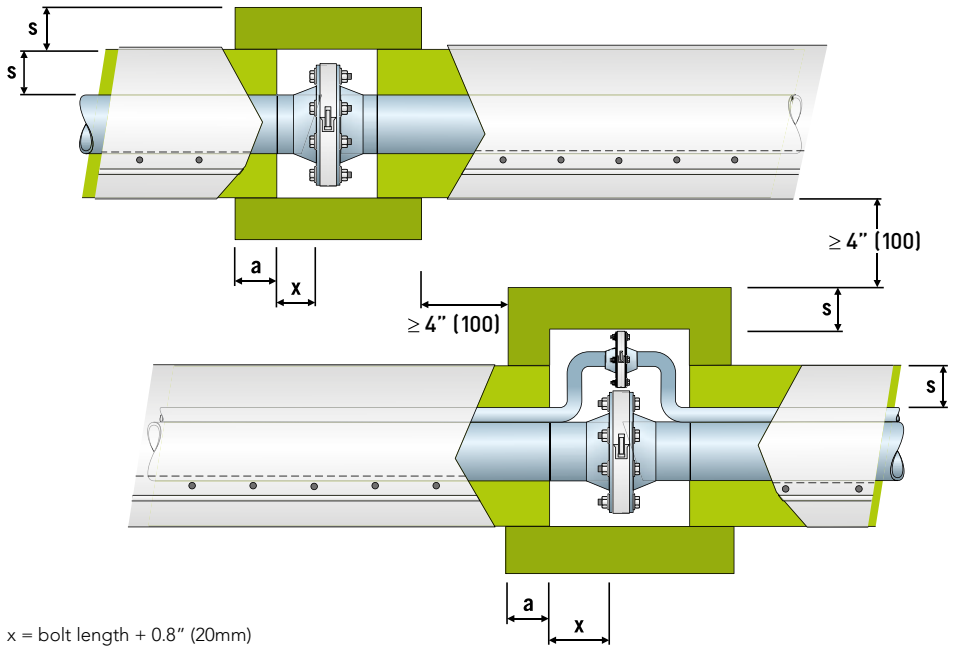

$x = \text{bolt length} + 0.8'' (20\text{mm})$
 $a = \text{overlap}, a \geq s$
 $s = \text{insulation thickness}$

1.1 Planning and preparation

A. Functional requirements

b) Operation of the installation

To select a suitable insulation system, the operating method of the installation must be considered. A basic distinction is made between continuous and interrupted operation. With continuous operation, the operating temperatures are constantly above or constantly below the ambient temperatures. The interrupted operating method, also referred to as intermittent or batch operation, is characterised by the fact that the installation is switched off between each operating phase and during that time can assume ambient temperatures. For special applications, so called dual temperature systems, the operating temperature alternates between above or below the ambient temperature.

c) Operating temperature

The appropriate insulation material should be resistant to the intended operating/peak temperatures. This product property is assessed by the maximum service temperature (also see Chapter 2.2 "Product properties").

d) Permissible heat losses or temperature changes of the medium

With many technical processes, it is essential that media in vessels, columns or tanks do not fall below a specific lower temperature limit, otherwise chemical processes will not proceed as intended or the media will set and can no longer be pumped or extracted. Over-cooling can lead to the precipitation of, for example, sulphuric acid in exhaust and flue gas streams, which furthers corrosion in the pipes or channels. With flowing media, it is essential to ensure that the temperature of the medium is still at the desired level at the end of the pipe. The thermal insulation is designed according to these requirements. Under extreme conditions (for example, lengthy periods of storage, long transport routes or extreme temperatures), installing tracing may be necessary, to ensure that the media is kept within the required temperature limits.

Use "Rockassist", a thermo-technical engineering calculation program, to ensure the optimum engineering and design of these insulations. Rockassist can help with estimating temperature drops with flowing or stagnant mediums. More information can be found on our website rti.rockwool.com. For special situations please contact ROCKWOOL Technical Insulation for further guidance.

Inside buildings, uninsulated or poorly insulated parts of installations can heat the room climate unnecessarily. This leads to higher room temperatures, which can have a negative effect on the working environment - both for the people who work long hours under these conditions and for the electronic components. In addition to the increased heat losses, further energy consumption is required to air condition the rooms. The design of the insulation and the related reductions in terms of heat losses from parts of installations should be relevant to the entire infrastructure and use of the building.

Rockassist thermo-technical calculation program

Go and register online for our free calculation tool

EXPERT TOOL

rti.rockwool.com



Rockassist is available on smartphone and tablet



e) Frost protection

Installations that are situated outside are at risk from frost in the winter. In addition to the undesirable malfunctioning of installations, installations also risk damage caused by the expansion of frozen water. Adequate measures – so called frost protection – must be taken to protect the installation from freezing. Insulation can reduce heat losses and postpone the moment at which the installation freezes. Insulation alone, however, cannot indefinitely prevent the installation from freezing. Installing additional tracing may be necessary between the object and the insulation. To prevent freezing, the insulation must be designed so that the density of heat flow rate of the insulated object is less than the heat conducted by the tracing.

f) Ambient conditions

Select an insulation system that offers long-lasting resistance to the surrounding environment.

- Atmospheric influences: wind, rain
- Mechanical loads such as vibrations or foot traffic
- Corrosive environment (close to the sea, chemicals,...)

Prevent the ingress of moisture into the insulation system. Moisture accumulation in insulation increases thermal conductivity and the risk of corrosion of the insulated installation components.

Cladding (jacketing) must be installed to prevent the ingress of moisture into the system. However, with installations situated outside or with installations operating intermittently, there is a high risk of moisture accumulation. This is caused by moisture condensing from the ambient air inside the cladding (jacketing).

For this reason, retain an air space of at least 1/4" (13 mm) between the insulation and the cladding (jacketing). In addition, drainage and ventilation holes of minimum 0.4" (10 mm) diameter and at intervals of maximum 12" (300 mm) should be provided on the underside or at the lowest point of the cladding (jacketing). If necessary, the insulation and cladding (jacketing) must resist chemical influences that develop within the environment.

g) Maintenance and inspection

To avoid complicating routine maintenance and inspection work unnecessarily with the insulation, maintenance-intensive areas must be taken into account, especially when designing the insulation work. Removable insulation systems, such as removable coverings and hoods, could be fitted in such areas, for example. Easily removable covering systems are also recommended for flanges and pipe fittings. These coverings are generally fastened with quick-release clamps, which can be opened without special tools. The insulation of fixtures such as flanges or pipe fittings must be interrupted at a sufficient distance to allow installation or dismantling to be carried out. In this case, take the bolt length at flange connections into consideration. The connection of the insulation should have an extremity and any fixtures in the range of the insulation, including the interruption in the installation, should be insulated with removable coverings.

1.1 Planning and preparation

B. Safety aspects

a) Personal protection

Surface temperatures in excess of 140°F (60°C) can lead to skin burns, if the surface is touched. Therefore, all accessible installation components should be designed to prevent people being exposed to the risk of injury by burns. The insulation applied to such plant components must ensure that surface temperatures in excess of 140°F (60°C) do not occur during operation. Use our thermo-technical engineering program "Rockassist" to calculate the required insulation thickness. All of the operational parameters must be known to achieve a reliable design, including, for example, the operating temperature, the ambient temperature, air movement, surface materials, distance from other objects, etc.

Note

As the surface temperature depends on a set of physical parameters, which cannot always be calculated or estimated with any degree of certainty, the surface temperature is not a guaranteed measurement. Also refer to Technical Letter No. 5 of the German BFA WKS B "The problem of guaranteeing surface temperatures". If the required protection (temperature) cannot be achieved by insulation, apply additional protective devices, such as safety guards or enclosure of the object.

b) Fire protection

The general fire protection requirements imposed on structural installations are usually defined within the local Building Codes or the specifications of plant owner. Structural installations must be designed, built, modified and maintained to prevent the outbreak of a fire and the spread of fire and smoke. In the event of a fire, the rescuing of people and animals and effectively extinguishing the fire must be made possible. During the design of the installation, it is vital to determine



the nature and scope of the fire prevention measures together with the building supervisory board, the fire brigade, insurance companies and the operator.

As a basic principle, consider the fact that the fire load in a building or technical installation can be considerably increased by flammable insulation materials. On the other hand, non-flammable insulation materials such as mineral wool, which has a melting point of > 1,830°F (> 1,000°C), not only have a positive impact on the fire load, but in the event of a fire, also constitute a certain fire protection for the installation component.

Installation components with tracing, in particular, which use thermal oil as a heat transfer medium, have an increased risk of catching fire in the event of a leak. In this case, ensure that the thermal oil cannot penetrate into the insulation material.

c) Explosion prevention

If there is a risk of fire and explosion, the surface temperature of the object and the cladding (jacketing) must be considerably lower than the ignition temperature of the flammable substance and/or gas mixtures. This requirement also

applies to thermal bridges, such as pipe mounting supports, supporting structures and spacers etc. With regard to insulation systems, explosion protection can only be achieved with a doubleskin covering. A doubleskin covering is a factory made cladding (jacketing) that has been welded or soldered to make it air proof and diffusion-resistant. In addition special (local) explosion regulations must be observed.



In explosive areas electrostatically charged substances like unearthed cladding (jacketing) or non-conductive plastics must be earthed. For further guidance please consult the German guideline BRG 132 (previously ZH 1/200 "Static Electricity").

d) Noise protection

The guidelines for noise in the ordinance and workplace are stated in the local regulations and standards. Generally, the level of the guideline values depends on the nature of the activity, such as:

- ARAB (Belgium)
- ARBO (Netherlands)
- Code du travail (France)
- ISO 15665

The sound propagation of installation components can be reduced using insulation systems. The nature and effect of the sound insulation depend on the frequency and the sound pressure level.

C. Economics

In the industry there are two grades of insulation. The first grade focuses on reducing heat losses and the prevention of injuries to people operating or working nearby the installations. The second grade of insulation, the so called "economical insulation thickness" focuses on significant heat loss reduction and as a result achieving a better return on investment.

a) Economical insulation thickness

Insulation reduces the heat losses from the object. The thicker the insulation, the greater the heat reduction and consequently, the more energy is saved. However, the investment and expenditure, e.g. for depreciation, interest rates and higher maintenance costs also rise if the insulation thickness is increased. At a certain insulation thickness, the sum of the two cost flows reaches a minimum. This value is known as the economical insulation thickness. A qualitative curve of a similar costs function is shown below.

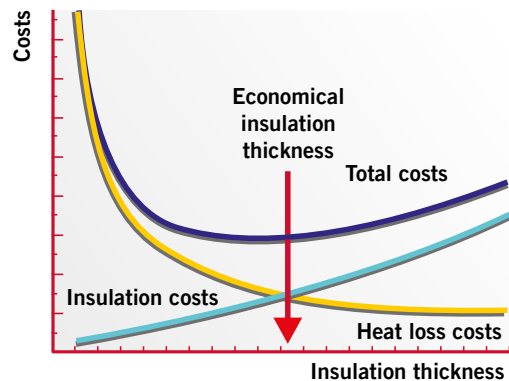

The German VDI guideline 2055 describes in detail various calculation methods used to determine the economical insulation thickness.

The energy costs cannot be based solely on the current price. Developments over recent years indicate that substantial increases in energy prices are also anticipated for the future.

1.1 Planning and preparation

C. Economics

Increasing energy prices are tending to bring about a shift in economic insulation thicknesses towards larger thicknesses.

b) Pay-back time

In addition to the economical insulation thickness, another frequently used economical parameter is the return on investment period (ROI), also referred to as the payback period. This is defined as the period within which the cost of the insulation is recuperated through savings on heat loss costs.

$$\text{ROI period} = \frac{\text{Costs of the insulation}}{\text{annual saving}} \quad [\text{a}]$$

In the case of technical insulation systems, the return on investment period is generally very short, often being much less than one year. Considering only the return on investment period, however, can be deceptive, as this approach disregards the service life of the installation. With long-life installations, it is advisable to select higher insulation thicknesses, even if this means accepting a longer return on investment period. Throughout the entire service life of the installation however, the increased insulation thickness results in a significantly higher return on the investment in insulation and achieves a much more economic operation of the installation.



D. Environmental

The burning of fossil fuels, such as coal, oil or gas, not only depletes the available primary energy sources, but also, due to the emission of carbon dioxide (CO₂) into the atmosphere, places a burden on the environment.

The increasing CO₂ concentration in the Earth's atmosphere plays a significant part in the global increase in temperature, also referred to as the "greenhouse effect". CO₂ absorbs the thermal radiation emanating from the earth's surface and in doing so reduces the dissipation of heat into space. This will lead to a change in the world's climate with as yet inestimable consequences. Reducing CO₂ emission can only be achieved through more efficient management of fossil fuels.

Increasing the insulation thicknesses is essential for the reduction of CO₂ emissions. Also refer to the Technical Letter No. 6 of the German BFA WKS B "High rate of return on environmentally friendly insulation layer thicknesses".

Reducing CO₂ emissions also has a positive financial benefit for businesses within the context of the EU emissions trading scheme. The benefits of increased insulation thicknesses in technical installations are twofold, as the costs for both energy consumption and CO₂ emissions are decreased.

E. Corrosion mitigation

See chapter 1.1.3

1.1.2 Design & planning of the insulation work

Requirements with regard to the insulation work to be done later must be included in the design and construction phase of industrial plants. It is therefore advisable to involve all project managers at an early stage, to preclude unnecessary and unprecedented problems during the insulation works from the outset.

All preparatory work must be completed according to the relevant insulation standards, such as DIN 4140, AGI Q05, BS 5970 and the CINI manual. The following preconditions must be fulfilled:

- If the equipment requires protection against corrosion, the application of the insulation shall not be commenced before the coating operation has been completed and approved. Uncoated stainless steel shall be clean and free of soluble salts (chlorides).
- Tracing and technical measurement equipment has been installed.
- The minimum distance between the objects has been observed (see illustrations on pages 12 and 13).
- The surface displays no coarse impurities.
- Mounting supports have been installed on the object to accommodate the support structure (For further guidance please consult AGI Q153, BS 5970 or the CINI manual).
- Collars and sealing discs have been fitted to the object (For further guidance please consult AGI Q152, BS 5970 or the CINI manual).
- Taps on the object are long enough to ensure that flanges lie outside the insulation and can be screwed on without hindrance.
- Supports are designed so that the load (weight) of the insulation, water vapour retarders, and cladding (jacketing) system can be distributed and therefore allow effective and professional installation. Emphasis should be given to a design that eliminates water traps and drains water away from the insulation system.
- The insulation can be applied without any obstacles (e.g. scaffolding).
- Welding and bonding work has been carried

out on the object.

- The foundations have been completed.

1.1.3 Corrosion mitigation

Corrosion under insulation – CUI – is recognized as one of industry's greatest challenges with respect to materials. CUI has been the cause of several accidents involving the loss of human life and personal injury, fire and pollution. One oil company estimates that CUI accounts for 40-60% of its pipeline maintenance costs. Globally, billions of euros are spent every year on problems arising from corrosion under insulation.

Corrosion occurs when unprotected metal (steel and stainless steel) comes into contact with water and oxygen, which is nothing out of the ordinary. We know about this from our old cars and other metal that is exposed outdoors.

With CUI, you cannot see the metal is corroding because the metal is concealed by insulation and cladding (jacketing). In some cases, the corrosion isn't discovered until a pipeline begins to leak. The environment under insulation can also be extra corrosive due to high temperatures and sometimes the presence of salts (e.g. chlorides) and other substances from various sources such as rain water, process water from wash down or condensation, that accelerate corrosion. Corrosion under insulation is a systemic challenge and must also be treated as such from the design phase through to scrapping. Important aspects are:

- The design must prevent water penetration and water traps inside the system, but also ensure there is sufficient space to apply the correct surface treatment and install the insulation and cladding (jacketing).
- The coating system/metallization is the primary corrosion protection and must be chosen according to the temperature – bearing in mind the system may be exposed to very hot water. Installation of the coating, including surface preparation, is critical for service life and performance.

1.1 Planning and preparation

- The insulation material must be optimized so that it does not accelerate corrosion.
- Cladding (jacketing) must be installed correctly so that water drains away from the surfaces, assemblies must be sealed, and drain holes provided.
- Cladding (jacketing) should include a high-quality continuous moisture barrier that is heat-laminated to the interior surface to help prevent a galvanic corrosion cell forming between the pipe/equipment and the cladding (jacketing).
- Polyfilm moisture barrier on the interior surface of the cladding (jacketing) to help prevent galvanic corrosion (which can be a type of CUI).
- Quality control is important throughout the process.
- Lastly, inspection routines must be drawn up and cladding (jacketing), insulation and coating systems under the insulation must be maintained after commissioning.

For further details on CUI we also refer to NACE SP0198 (Control of Corrosion Under Thermal Insulation and Fireproofing Materials – A Systems Approach), which gives detailed information on generic coating types for use under insulation, and the more detailed documents:

- European Federations of Corrosion Publications No. 55, Corrosion under insulation (CUI), guidelines.
- API RP 583 Corrosion Under Insulation and Fireproofing.

Corrosion under insulation is most prone to occur on carbon steel operating in the temperature range 25°F (-4°C) to 350°F (175°C) and on stainless steel in the range 120°F (50°C) to 350°F (175°C).

As previously stated, corrosion mitigation (prevention) is a systemic approach, from the design phase to scrapping. In relation to materials, the important parameters are the selection and installation of coating system, and selection and installation of insulation material and cladding (jacketing). The coating system/

metallization is the primary corrosion protection and must be chosen according to the temperature – bearing in mind the system may be exposed to very hot water. Installation of the coating, including surface preparation, is critical for service life and performance.

Good guidelines to the choice of coating system for use under insulation is found in **NACE SP0198**. The coating material supplier's instructions should be followed with regard to surface preparation and application.

Corrosion under insulation is possible under all types of insulation, the insulation material will not prevent or cause corrosion, but it may influence the rate of corrosion:

As per NACE SP0198, the following insulation characteristics have the greatest influence on corrosion:

1) Water leachable salt content in insulation such as chloride:

We recommend insulation materials with a chloride content of less than 10mg/kg (EN 13468) and/or that comply with ASTM C795, as this not only ensures a material that is safe for use directly on stainless steel, but will also not accelerate corrosion of carbon steel.

2) Water retention, permeability and wettability:

For insulation systems for hot service, we recommend the use of an insulation material that is open to water vapour diffusion, as this allows water egress from the insulation system, preventing water entrapment on the metal surface. To minimise liquid water ingress, the material should be water repellent, with water absorption of less than 1kg/m² when measured according to EN 1609/EN 13472. The CUI risk is highest for pipelines and for pipe insulation. It is therefore recommended to use a product with even better water repellency, with a water absorption of less than 0.2kg/m² when measured according to EN 1609/EN 13472 and properties that are thermally stable up to 482°F (250°C).

3) Foams containing residual compounds that may react with water to form hydrochloric or other acids: We recommend the use of stone wool based insulation materials, which are inert and have a pH that is neutral to slightly alkaline.

Cladding (jacketing) is applied to the insulation to keep the insulation dry. Sealants are used for joints and protrusions to ensure that the weather barrier is as tight as possible. Cladding (jacketing) should be selected as per expected service conditions – mechanical, chemical and UV light exposure.

Combat the risk of CUI - corrosion under Insulation

CUI is a major issue in the industry. It leads to higher maintenance costs and can cause pipe leaks or even ruptures. According to NACE*, water-leachable salt, water retention, permeability and wettability all play a major role in mitigating the risk of CUI.

Our next generation ProRox mandrel wound pipe sections and wired mats with WR-Tech™ (Water Repellency Technology) get to grips with CUI. They absorb less water, dry faster, are more durable and have a very low water-leachable salt content. Minimising the risk of corrosion under insulation.

*NACE SP0198-2017, Control of Corrosion Under Thermal Insulation and Fireproofing Materials.

LOWEST WATER ABSORPTION

< 5X LESS WATER ABSORPTION, EVEN AFTER HEATING AND AGING

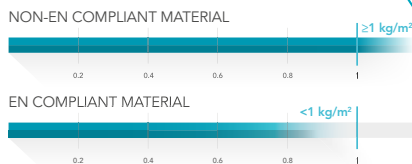

PROROX WITH WR-TECH

NON HEATED, NON AGED

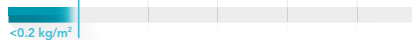

AFTER HEATING AT 250°C FOR 24H

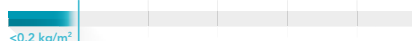

AFTER AGING IN AMBIENT CONDITIONS FOR 6 MONTHS



Next generation ProRox solutions with WR-Tech



SILICONE OIL FREE

Complies with VW specification PV 3.10.7, does not result in fish-eyes, usable in paint shops.

FASTEST WATER DISSIPATION

Open vapour structure ensures fastest dry-out time.

PROROX WITH WR-TECH

2 HOURS' IMMERSION

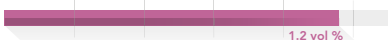

AFTER 2 HOURS' RECOVERY



AFTER 48 HOURS' RECOVERY



LOW WATER LEACHABLE CHLORIDE CONTENT

Safe to use over steel.

Complies with strict industry standards ASTM C795 and EN 13468.



1.1 Planning and preparation

The table further on this page, which has been derived from the standard DIN 4140, indicates the initial risks of electrochemical corrosion in cases where various combinations of metals are used.

Note

The table does not take into account forms of corrosion with other root causes, such as stress corrosion. For further information, see Chapter 2.2 "Product properties" – AS-quality.

Material		Combination material					
Metal	Surface ratio in proportion to combination material	Zinc	Aluminium	Ferritic steel	Lead	Austenitic stainless steel	Copper
Zinc	Small	-	M	M	H	H	H
	Large	-	L	L	L	L	L
Aluminium	Small	L	-	L	H	H	H
	Large	L	-	L	M	L	H
Ferritic steel	Small	L	L	-	H	H	L
	Large	L	L	-	L	L	L
Lead	Small	L	L	L	-	H	H
	Large	L	L	L	-	M	M
Austenitic stainless steel	Small	L	L	L	L	-	M
	Large	L	L	L	L	-	L
Copper	Small	L	L	L	L	L	-
	Large	L	L	L	L	L	-

L - Light or little corrosion to material

M - Moderate corrosion to material, for example, in very humid atmospheres

H - Heavy electrochemical corrosion to material

Observation: The table shows the corrosion of the "material", and not that of the "combination material".

"Light" means: "small-scale in proportion to the combination material", "heavy" means: "large-scale in proportion to the combination material".

Example 1: Material is a zinc galvanised screw in combination material, a cladding (jacketing) made from austenitic stainless steel: Row "zinc small": "H" – heavy corrosion of the screw.

Example 2: Material, a cladding (jacketing) made from austenitic stainless steel screwed on with a screw galvanised with combination material zinc: Row "austenitic stainless steel large". "L" – the corrosive attack upon the austenitic steel is light.

1.1.4 Storage of insulation materials

Incorrect storage of insulation materials outdoors can – mainly due to moisture – influence the performance of the material. Moisture in insulation materials has the following negative influences. The thermal conductivity of water is approximately 25 times greater than that of air, which is present in cells or between the fibres in insulation.

An increase in moisture therefore results in an increase in the thermal conductivity of the insulation and, correspondingly, a decrease in the insulation efficiency. Even a moisture content of 5 % can result in an increase of thermal conductivity by 25 %. A higher moisture also means a significantly higher weight, which, as a rule, is not taken into account in the static design of an insulation system. Moisture causes many types of corrosion that virtually never develop in a dry system. The major types of corrosion in relation to insulation technology are oxygen, electrochemical and stress corrosion. Insulation materials for austenitic components, which in stainless steel quality are manufactured with a low chloride ion content, irrecoverably lose this property when moisture is introduced. Insulation materials must be protected against moisture when stored, during installation and when fitted. If storage in a closed structure is impossible, protect the insulation material from weather influences by covering it with waterproof material. Ensure the insulation is not in direct contact with the floor; otherwise it may become wet as a result of ground moisture.

For further information please see our website rti.rockwool.com. Go to the "Documentation" section for our "Storage and handling guideline" for ROCKWOOL ProRox insulation material.





1. System solutions

1.2 Insulation of piping

Piping plays a central role in many industrial processes in chemical or petrochemical installations such as power plants, as it connects core components such as appliances, columns, vessels, boilers, turbines etc. with one another and facilitates the flow of materials and energy. To guarantee a correct process cycle, the condition of the media within the pipes must remain within the set limitations (e.g. temperature, viscosity, pressure, etc.). In addition to the correct isometric construction and fastening of the piping, the piping insulation also has an important function. It must ensure that heat losses are effectively reduced and that the installation continues to operate economically and functionally on a permanent basis. This is the only way to guarantee the maximum efficiency of the process cycle throughout the design service life without losses as a result of faults.

Requirements for industrial piping

The basic efficiency and productivity factors of piping for the processing industry include energy efficiency, dependability and reliability under different conditions, in addition to the functionality of the process control, an appropriate structure that is suitable for the operating environment, as well as mechanical durability. The thermal insulation of piping plays a significant role in fulfilling these requirements.

Thermal insulation

The functions of proper thermal insulation for piping include:

- Reduction of heat losses (cost savings)
- Reduction of CO₂ emissions
- Frost protection
- Process control: ensuring the stability of the process temperature
- Noise reduction
- Condensation prevention
- (Personal) protection against high temperatures
- Fire protection



ROCKWOOL ProRox products for pipe insulation

We offer a wide range of high-quality stone wool insulation products for the insulation of industrial plants. All products are part of our extensive ProRox range for technical insulation. With this specific field of application in mind we developed our pre-formed mandrel wound pipe sections, load bearing mats (wrap) as well as various wired mats for pipe insulation. All these products are easy to install and contribute to a high level of efficiency, functionality and reduced heat losses. Continuous internal and external inspection and high levels of quality assurance ensure the consistently high quality of all ROCKWOOL Technical Insulation products.

The examples of use below cannot fully take into account the particular circumstances of the construction-related factors. Determine whether the products are suitable for the corresponding application in each individual case. If in doubt, consult our sales consultants and technical service managers.

The applicable standards and regulations must also be observed. A few examples follow:

- NACE SP0198 (Control of corrosion under thermal insulation and fireproofing materials - a systems approach)
- MICA (National Commercial & Industrial Insulation Standards)
- DIN 4140 (Insulation works on technical industrial plants and in technical facility equipment)
- AGI Q101 (Insulation works on power plant components)
- CINI-Manual "Insulation for industries"
- BS 5970 (Code of practice for the thermal insulation of pipework, ductwork, associated equipment and other industrial installations)

1.2 Insulation of piping

Hot insulation systems

Principally, a thermal insulation structure for piping consists of an appropriate insulating material, usually covered by metal cladding (jacketing). This protects the object and the insulation from external influences such as the weather or mechanical loads. Spacers are also essential with insulation such as wired mats, which do not offer sufficient resistance to pressure to hold the weight of the cladding (jacketing) and other external loads. These spacers transfer the cladding (jacketing) loads directly onto the object. In the case of vertical piping, support structures are fitted to take on the loads of the insulation and the cladding (jacketing). In general, support structures and spacers form thermal bridges.

Selecting a suitable insulation system depends on numerous parameters. These are described in greater detail in Chapter 1.1. Regarding the different forms of piping insulation, a fundamental distinction can be drawn between the following insulation systems.

Insulation with ProRox mandrel wound pipe sections

Generally, the best insulation is achieved using ProRox mandrel wound pipe sections with WR-Tech (Water Repellency Technology). We have a wide range of mandrel wound pipe sections with WR-Tech for large and small pipes that satisfy all requirements. The ProRox mandrel wound pipe sections are made of stone wool and incorporate WR-Tech, an innovative water-repellent binder to mitigate the risk of corrosion under insulation. The ProRox pipe sections with WR-Tech are available with or without reinforced aluminium foil covering. The sections can be used up to temperatures of 1200°F (650°C) or 1400°F (760°C) when using ProRox PS 980^{NA} Type V insulation. They are supplied ready split and hinged for quick and easy snap-on assembly and are suitable for thermal and acoustical insulation of industrial pipe work.

Due to their excellent fit and high compression resistance mandrel wound pipe sections with WR-Tech can often be applied in a single layer without any additional spacers.

If multiple layers are required, we can also supply double layered - so called 'nested' - mandrel wound pipe sections with WR-Tech. This reduces installation costs considerably. Also the number of thermal bridges, which have a negative influence on the insulation, is greatly reduced, while a lower thickness may be applied compared to wired mats.

Using mandrel wound pipe sections with WR-Tech for the insulation of pipes results in considerably reduced installation time and costs. The lack of spacers and "unforeseen" gaps minimises heat losses and the risk of personal injuries due to hot spots on the cladding (jacketing). At temperatures above 550°F (300°C), the provisional application of spacers should be determined in each individual case. Last but not least our ProRox mandrel wound stone wool pipe sections with WR-Tech helps to minimize the risk of corrosion under insulation. They absorb less water, dry faster, are more durable and have a very low water-leachable salt content. (see also chapter 1.13 Corrosion mitigation).

Mandrel wound pipe sections with WR-Tech are always precisely tailored to the corresponding pipe diameter to minimise the risk of convection and processing defects. ProRox mandrel wound pipe sections with WR-Tech are available in diameters of NPS 1/2" (23 mm) to NPS 36" (915 mm).



Insulation with ProRox load-bearing mats (wrap)

Load bearing mats (wrap), such as ProRox MA 520 ALU and ProRox MA 960^{NA}, are the latest development in the insulation sector. ProRox MA 520 ALU is a stone wool insulation mat (wrap) with a special fibre structure, bonded onto fibreglass reinforced aluminium foil. The flexible application makes the mats (wrap) easy to cut. ProRox MA 960^{NA} is a stone wool insulation mat (wrap) that is available with a black fibrous scrim. Reinforced aluminium foil facing is available upon request. It is designed for easy installation of large diameter pipes, vessels and equipment.

Typical applications include:

- pipe diameters >NPS 12" (\geq DN 300), or;
 - piping with a high number of shaped pieces such as elbows or T-joints.
 - pipe diameters <NPS 12" (\leq DN 300) in a double layer system (first layer with ProRox PS 960, second layer with ProRox MA 520 ALU) without support constructions.
- ProRox MA 520 ALU can be applied up to temperatures of 550°F (300°C). ProRox MA 960^{NA} can be applied up to temperatures of 1200°F (650°C). Their high compression resistance means, that in many cases, ProRox load bearing mats (wrap) can be applied without any additional spacers.



Consequently the number of thermal bridges, which have a negative influence on the insulation, is greatly reduced. The result is considerably reduced installation time and costs. The lack of spacers and "unforeseen" gaps minimises heat losses and the risk of personal injuries due to hot spots on the cladding (jacketing). At temperatures above 550°F (300°C) also load-bearing mats (wrap) need spacers, and then ProRox wired mats may be a more efficient alternative.

Load-bearing mats (wrap) are tailored to the corresponding length of the pipe circumference on site and are fastened with clamps.

Insulation with ProRox wired mats

Wired mats, such as ProRox WM 950, are lightly bonded stone wool mats and are available with WR-Tech, an innovative water-repellent binder to mitigate the risk of corrosion under insulation and to ensure the thermal performance during operation. They are usually stitched with galvanized wire onto a galvanized wire mesh.

Pipe insulation with ProRox wired mats has been a time-tested universal solution for many decades now. Due to their flexibility and high temperature resistance, wired mats can be easily cut and mounted onto the piping. These wired mats are ideal for application in situations where the use of ProRox mandrel wound pipe sections with WR-Tech or ProRox load bearing mats (wrap) is difficult or impossible:

- temperatures above 550°F (300°C)
- pipe diameters \geq DN 350 (14 inches),
- piping with a high number of shaped pieces such as elbows or T-joints.

ProRox wired mats have a relatively low resistance to pressure and from a practical point of view should only be mounted in combination with spacers or support structures. Because of the resulting thermal bridges, better insulation performances are often achieved in the lower and middle temperature range [up to 550°F (300°C)] with ProRox mandrel wound pipe sections with WR-Tech or load bearing mats (wrap) rather than with wired mats.

1.2 Insulation of piping

Comparison of the different insulation systems

The particular advantage of ProRox mandrel wound pipe sections with WR-Tech and load-bearing mats (wrap) lies in the fact that support structures are not required and therefore thermal bridges caused by the insulation are minimised or removed. On the other hand, wired mat systems have their advantages due to their maximum service temperature in the case of hot face insulation.

The advantages of ProRox mandrel wound pipe sections with WR-Tech and load-bearing mats (wrap) at a glance are:

- It is not necessary to install spacers or support structures.
- Faster application without the interference of spacers.

- Both products offer an even, firm surface for installing the cladding (jacketing).
- The lack of spacers gives rise to lower heat losses.
- It yields an even surface temperature across the cladding (jacketing).
- In comparison to wired mats, a more shallow insulation thickness can be applied.
- The operating costs of the installation decrease as a result of lower heat losses.

Generally speaking, a spacer or support structure functions as a thermal bridge, as a result of which the heat loss in the total insulation is increased considerably.

Insulation system with a spacer ring to illustrate heat loss (thermal bridge)

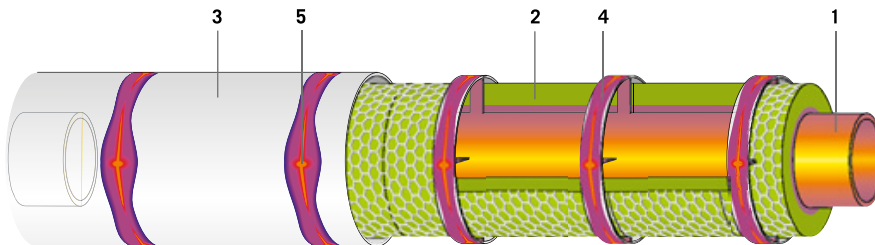

1. Pipe - 2. Insulation: ProRox wired mats - 3. Cladding (jacketing) - 4. Spacer ring - 5. Heat loss

Insulation system without a spacer ring

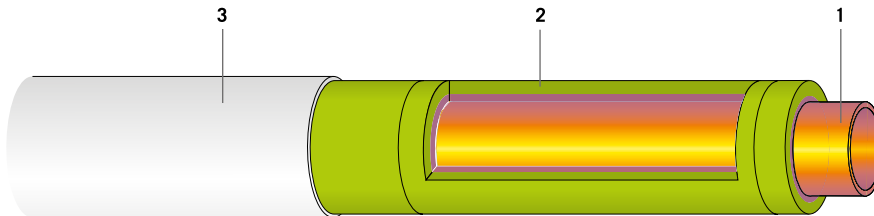

1. Pipe - 2. Insulation: ProRox pipe sections with WR-Tech or Load bearing mats (wrap): ProRox MA 520 ALU or ProRox MA 960^{NA} - 3. Cladding (jacketing)

Required insulation thicknesses

Please consult chapter: 2.3 'Bases for thermal calculation' and/or Rockassist, our online thermo-technical calculation program.

Go and register
online for our
free Rockassist
calculation tool

EXPERT TOOL



Rockassist is available on smartphone and tablet

1.2 Insulation of piping

Selection of pipe insulation systems

ProRox mandrel wound pipe sections with WR-Tech (Water Repellency Technology) generally get the best insulation results. We offer a wide range of mandrel wound pipe sections with WR-Tech for large and small pipes that satisfy all requirements. The ProRox mandrel wound pipe sections are made of stone wool and incorporate WR-Tech, an innovative water-repellent binder to mitigate the risk of corrosion under insulation. The sections are quick and easy to install. Their excellent fit and high compression resistance means ProRox mandrel wound pipe sections with WR-Tech can be applied in a single layer without any additional spacers. They also have a lower insulation thickness. Load bearing mats (wrap), are usually applied for the insulation of large pipe diameters and shaped pieces like elbows and T-joints. Generally, ProRox wired mats are applied within the higher temperature range [$T > 550^{\circ}\text{F}$ ($> 300^{\circ}\text{C}$)].

Generally speaking, a spacer or support structure functions as a thermal bridge, as a result of which the heat loss in the total insulation is increased considerably.

The design of an insulation system depends upon many factors such as the dimensions, mechanical loads, safety aspects, economics, etc. Consequently this also requires a considered selection of the insulation material. Use the application matrix on the next page as a guide.

Comparison

ProRox mandrel wound pipe sections with WR-Tech and load-bearing mats (wrap) offer the advantage that spacers are generally not required.

- ProRox mandrel wound pipe sections with WR-Tech and load-bearing mats (wrap) are applied more quickly without the interference of spacers.
- Both products offer an even, firm surface for installing the cladding (jacketing).
- The lack of spacers creates lower heat losses
- It yields an even surface temperature across the cladding (jacketing)
- In comparison to wired mats, a more shallow insulation thickness can be used. With a same insulation thickness, the operational costs of the installation decrease as a result of lower heat losses.

Application	Temperature		Mandrel wound pipe section with WR-Tech	Load bearing mats (wrap)			Wired mats with WR-Tech*/ Wired mats	
	°F	°C		ProRox PS 960	ProRox MA 520 ALU	ProRox MA 960 ^{NA}	ProRox WM 951*/ WM 950	ProRox WM 961*/ WM 960
Piping	< 550°F	< 300°C	•••••	•••	•••	••	•	
	550°F - 1100°F	300°C - 600°C	•••		•••	••	•	
	> 1100°F	> 600°C					•••	
Short sections, (many) elbows, valves, flanges	< 550°F	< 300°C	•	••••	••••	•••	••	
	550°F - 1100°F	300°C - 600°C	•		••••	•••	••	
	1100°F - 1200°F	600°C - 660°C					•••	
Piping with tracing			•••••	•••	•••	••	•	
City heating pipes	D ≤ 14"	D ≤ 356 mm	•••••	••••	••••			
	D > 14"	D > 356 mm	••••	•••••	•••••			

Note: ••••• = most optimal product

1.2 Insulation of piping

1.2.1 Insulation with ProRox mandrel wound pipe sections

For the best insulation results, ProRox mandrel wound pipe sections with WR-Tech (Water Repellency Technology) are generally recommended. The sections can be used up to temperatures of 1200°F (650°C). They are supplied ready split and hinged for quick and easy snap-on assembly and are suitable for thermal and acoustic insulation of industrial pipe work. Their excellent fit and high compression resistance means mandrel wound pipe sections can be applied in a single layer without any additional spacers or support structures. Consequently the number of thermal bridges, which have a negative influence on the insulation, is greatly reduced, while a low thickness may be applied compared to wired mats. The result is considerably reduced installation time and costs. The lack of spacers and “unforeseen” gaps minimises heat losses and the risk of personal injuries due to hot spots on the cladding (jacketing).

At temperatures above 660°F (350°C), the provisional application of spacers must be determined in each individual case. ProRox mandrel wound pipe sections are available in a wide range of diameters, ranging from NPS 1/2" (23 mm) to NPS 36" (915 mm).

Note

Due to their low thermal conductivity, better thermal insulation values can be achieved with mandrel wound pipe sections with WR-Tech than, for example, with wired mats. With insulation on straight mandrel wound pipe sections, a combination of both products in the same insulation thickness is therefore not advisable. If this combination is essential, for example, in the case of bends or shaped pieces, it is vital to select the correct insulation thickness. This is the only way to guarantee that no unexpected, potentially hazardous surface temperatures occur.

Insulation thicknesses to guarantee protection against contact

Please consult chapter 2.3: Bases for thermal calculation and/or Rockassist, our online thermo-technical calculation program.

Installation

Before starting the insulation works, ensure that all preparatory work on the object has been completed. Refer to Chapter 1.1 for details.

The ProRox PS 960 mandrel wound pipe section is mounted directly onto the pipe to form a close fit. With horizontal pipes, the lengthwise joint of the mandrel wound pipe section should be turned towards the underside at the 6 o'clock position. For systems that have a higher risk of water infiltration, the joint shall be oriented in a position that best prevents water migrating to the pipe. With vertical pipes, the lengthwise joints should be staggered at an angle of 30° to one another. Secure the mandrel wound pipe sections with galvanised binding wire or with steel bands. With an insulation thickness exceeding 5 inches (120 mm) [or temperatures > 550°F (300°C)], install the insulation in at least two layers. If the insulation is assembled in multiple layers, the joints of the individual insulation layers must be staggered.

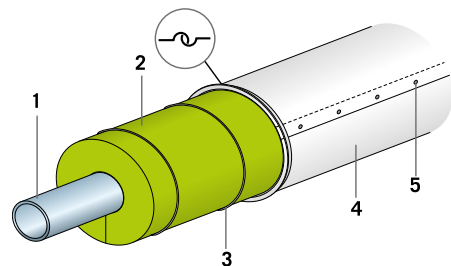

1. Pipe - 2. Insulation: ProRox pipe sections with WR-Tech -
3. Clamp or binding wire - 4. Cladding (jacketing) -
5. Sheet-metal screw or rivet - 6. Heavy Mass layer

Support structures and spacers

Spacers are not generally essential in insulation systems with mandrel wound pipe sections. With pipes that are exposed to large mechanical loads (e.g. strong vibrations) and/or temperatures above 660°F (350°C), determine whether a spacer ring is required in each individual case.

With pipes that have been installed vertically, with a height in excess of 20 feet (6 m), fit support structures to transfer the dead load of the insulation system onto the pipe. Attach the first support ring to the lowest point of the vertical pipe. The distance between the support rings should not exceed approximately 20 feet (6 m).

1.2 Insulation of piping

1.2.2 Insulation with ProRox load-bearing mats (wrap)

Load bearing mats (wraps) such as ProRox MA 520 ALU and ProRox MA 960^{NA} are the latest development in the insulation business. ProRox MA 520 ALU is a stone wool insulation mat (wrap) with a special fibre structure, bonded onto fibreglass reinforced aluminium foil. ProRox MA 960^{NA} is a stone wool insulation mat (wrap) available with black mat (wrap) or reinforced foil facing. The flexible application makes the mats (wrap) easy to cut. Load bearing mats (wrap) are ideal for application as pipe insulation in situations where the use of mandrel wound pipe sections is difficult. For instance where pipe diameters \geq DN 350, or in case of a high number of shaped pieces such as elbows or T-joints.

ProRox MA 520 ALU can be applied up to temperatures of 550°F (300°C). The main advantage of ProRox MA 520 ALU is relative high compression resistance that allows the use of the product without support construction. At temperatures above 550°F (300°C) this advantage is lost and in addition also the thermal conductivity is less good at such temperatures compared to other products. So even when the product has a

maximum service temperature of 932°F (500°C), better and more cost efficient insulation solutions can be made with ProRox wired mats or pipe sections or pipe sections in combination with ProRox MA 520 ALU for equipment operating at temperatures above 550°F (300°C).

ProRox MA 960^{NA} can be applied up to temperatures of 1200°F (650°C). Due to the high compression resistance, load bearing mats (wrap) can be applied without additional spacers in many cases. Consequently, the number of thermal bridges which have a negative influence on the insulation, is greatly reduced.

The result is considerably reduced installation time and costs. The lack of spacers minimises heat losses and the risk of personal injuries caused by hot spots on the cladding (jacketing). Load-bearing mats (wraps) are precisely tailored to the corresponding length of the pipe circumference on site and are fastened with clamps.

Insulation thicknesses to guarantee protection against contact

Please consult chapter 2.3: Bases for thermal calculation and/or Rockassist, our online thermo-technical calculation program.

Go and register online for our free Rockassist calculation tool

EXPERT TOOL

ti.rockwool.com



Rockassist is available on smartphone and tablet

Installation

Before starting the insulation works, ensure that all preparatory work on the object has been completed. Refer to Chapter 1.1 for details.

Cut the mats (wrap) to the required length, based on the external insulation diameter (pipe diameter + two times the insulation thickness). Fasten the mat (wrap) firmly to the pipe with steel bands. Ensure that the mats (wrap) form a tight joint and that no lengthwise joints or circular joints are visible. The joints of the individual mats (wrap) are securely taped with self-adhesive aluminium tape. If the insulation is assembled in multiple layers, the joints of the individual insulation layers must be staggered.

Support structures and spacers

Spacers are not generally essential in insulation systems with load bearing mats (wrap). With pipes that are exposed to large mechanical loads (e.g. strong vibrations), determine whether a spacer ring is required in each individual case.

With pipes that have been installed vertically, with a height in excess of 20 feet (6 m), fit support structures to transfer the dead load of the insulation system onto the pipe. Attach the first support ring to the lowest point of the vertical pipe. The distance between the support rings should not exceed approximately 20 feet (6 m).

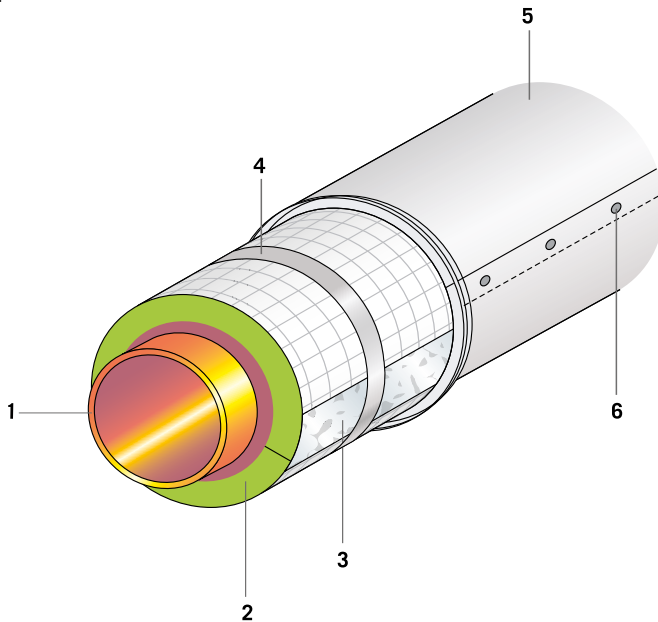

1. Pipe - 2. Insulation: ProRox load bearing mat (wrap) - 3. Self-adhesive aluminium tape - 4. Steel bands -
5. Cladding (jacketing) - 6. Sheet-metal screw or rivet

1.2 Insulation of piping

1.2.3 Insulation with ProRox wired mats

Pipe insulation with ProRox wired mats has been a time-tested universal solution for many decades now. Due to their flexibility and high temperature resistance, wired mats can be easily cut and mounted onto the piping. These ProRox wired mats are ideal for application on large pipe diameters and shaped pieces as elbows or T-joints.

ProRox wired mats have a relatively low resistance to pressure and from a practical point of view should only be mounted in combination with spacers. Because of the resulting thermal bridges, better insulation performances are often achieved in the lower and middle temperature range [up to 550°F (300°C)] with mandrel wound pipe sections or load bearing mats (wrap) rather than with wired mats.

Insulation thicknesses to guarantee protection against contact

Please consult chapter 2.3 Bases for thermal calculation and/or our Rockassist program.

Installation

Before starting the insulation works, ensure that all preparatory work on the object has been completed. Refer to Chapter 1.1 for details.

Cut the mat (wrap) to a length so that it can be fitted to the pipe with slight pre stressing. Wire the closing joints (lengthwise and circular) of the mats (wrap) together using steel wire (0.02 inch or 0.5 mm thickness) or secure with mat (wrap) hooks. Stainless steel pipes and pipes with an operating temperature > 750°F (400°C) can only be insulated with wired mats with stainless steel stitching wire and wire netting to prevent galvanic corrosion cracking.

With an insulation thickness of more than 5 inches (120 mm) [or temperatures > 550°F (300°C)], apply multiple layer insulation. If the insulation is assembled in multiple layers, the lengthwise and crosswise joints of the individual insulation layers must be staggered. If mechanical loads are anticipated, use steel straps to secure the wired mats.

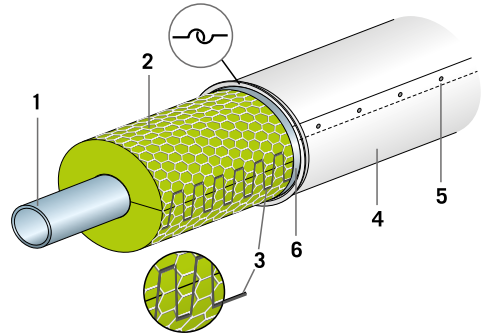

1. Pipe - 2. Insulation: ProRox wired mats -
3. Stitching of the joint edge with binding wire -
4. Cladding (jacketing) - 5. Sheet-metal screw or riveted bolt -
6. Spacer ring

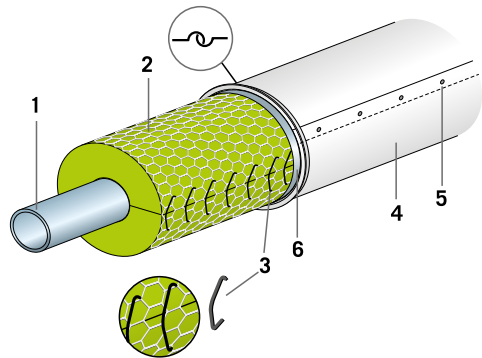

1. Pipe - 2. Insulation: ProRox wired mat- 3. Joint edge closed with mat (wrap) hooks -
4. Cladding (jacketing) -
5. Sheet-metal screw or riveted bolt -
6. Spacer ring

Support structures and spacers

As wired mats do not offer sufficient resistance to pressure to bear the weight of the cladding (jacketing), spacer or support structures should be applied at intervals of about 1 m for pipes located horizontally and vertically.

1.2 Insulation of piping

1.2.4 Insulation support

A. Spacers

The purpose of spacers is to keep the cladding (jacketing) at a predetermined distance from the pipe. Spacers are essential when the insulation (e.g. wired mats) cannot bear the mechanical load of the cladding (jacketing). At temperatures lower than 660°F (350°C), the use of spacers is generally not necessary if ProRox mandrel wound pipe sections or load-bearing mats (wrap) are used. However, a support structure or spacers on pipes is recommended where mechanical loading of the insulation is expected (e.g. strong vibrations) and/or the temperature is higher than 660°F (350°C).

Spacer rings usually consist of metal rings on which the cladding (jacketing) rests, and metal or ceramic bars used as spacers, which rest on the pipe. Elastic spacers such as Omega clamps are frequently used to reduce the transference of vibrations. With steel spacers, apply at least three bars, whereby the total maximum distance – measured as circumference of the external ring – must be no more than 16 inch (400mm). With ceramic spacers, apply at least four bars at a maximum permissible distance of 10 inch (250mm). Ideally, the spacers are positioned under the cladding overlap to reinforce the joint in case of additional mechanical loads (foot traffic).

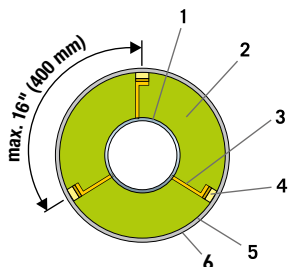

1. Pipe - 2. ProRox insulation - 3. Spacer - 4. Thermal dividing layer - 5. Support ring - 6. Cladding (jacketing)

The number of spacers depends on the insulation, temperature and the mechanical load. If nothing else is specified or local experience/practice does not exist, use the following intermediate distances provided by CINI 1.3.23 as a guide. Please note

that depending on local standards, the temperature range can differ.

Insulation system	Horizontal piping		Vertical piping	
	≤ 660°F ≤ 350°C	> 660°F > 350°C	≤ 660°F ≤ 350°C	> 660°F > 350°C
Mandrel wound pipe sections with WR-Tech	none	*	20 ft 6 m	20 ft 6 m
Load bearing mats (wrap)	none	*	20 ft 6 m	20 ft 6 m
Wired mats	3.3 ft 1 m	3.3 ft 1 m	3.3 ft 1 m	3.3 ft 1 m

*In accordance with CINI 1.3.23 at process temperatures above 660°F (350°C), spacers should be applied, in consultation with the designer.

The spacers on pipes are located under the circular joint of the cladding (jacketing). On shaped sections such as pipe elbows, spacers are fitted at both ends. If the external distance between the two spacers exceeds 27 inch (700mm), place additional spacers between them.

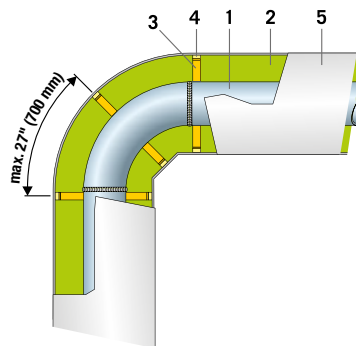

1. Pipe - 2. ProRox insulation - 3. Spacer - 4. Thermal dividing layer - 5. Cladding (jacketing)

B. Support construction

The purpose of support structures is to transfer the mechanical load of the insulation system and the forces affecting the insulation system onto the object. Support structures are essential in the case

of vertical piping. In addition to the static and dynamic forces, changes in piping length and support structures due to temperature must also be taken into account when dimensioning. Support structures are fastened to mounting supports, which are welded to the pipe beforehand, or are clamped directly onto the pipe with double clamping rings. For temperatures above 660°F (350°C), the support structures must be made of high-temperature steels.

The table below is an initial dimensioning guide, and states the weight of the insulation system against the nominal width of the pipe and the insulation thickness. The table accounts for an insulation with an apparent density of 6 lb/ft³ (100 kg/m³), including the spacer and a 0.04 inch

(1.0 mm) strong galvanised sheet 0,95 lb/ft² (11 kg/m²).

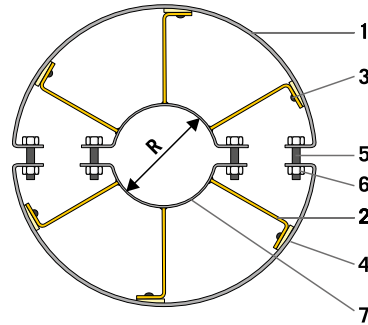

- 1. Support ring - 2. Bar - 3. Rivet or screw connection -
- 4. Thermal decoupling - 5. Clamping screw - 6. Screw nut - 7. Internal clamping ring

Weight of the insulation (kg/m and lb/ft pipe)

Pipe diameter			Weight of insulation system in relation to different insulation thicknesses	Insulation thickness in inch (mm)							
NPS (inch)	Nominal diameter Ø DN	mm		1.00 (30)	1.50 (40)	2.00 (50)	2.50 (60)	3.50 (80)	4.00 (100)	5.00 (120)	6.00 (140)
0,5	15	21	lb /ft	0.3	0.5	0.8	1.1	1.5	2.5	3.7	5.2
			kg/m	4	5	6	8	11	15	19	24
1,0	25	34	lb /ft	0.5	0.7	1	1.4	1.8	2.8	4.1	5.7
			kg/m	4	5	7	8	12	15	20	25
2,0	50	60	lb /ft	0.8	1.1	1.5	1.9	2.4	3.6	5	6.7
			kg/m	5	7	8	10	13	17	22	27
2,5	65	76	lb /ft	1.0	1.3	1.7	2.2	2.7	4.0	5.5	7.2
			kg/m	6	7	9	10	14	18	23	28
3,0	80	89	lb /ft	1.2	1.5	2.0	2.5	3.0	4.3	5.9	7.7
			kg/m	7	8	10	11	15	19	24	29
4,0	100	114	lb /ft	1.5	2.0	2.5	3.0	3.6	5.1	6.8	8.7
			kg/m	8	9	11	12	16	21	26	31
8,0	200	219	lb /ft	2.9	3.6	4.4	5.2	6.1	8.1	10.3	12.8
			kg/m	12	14	16	18	23	28	33	39
12,0	300	324	lb /ft	4.4	5.3	6.3	7.4	8.5	11	13.8	16.8
			kg/m	17	19	21	24	29	35	41	47
20,0	500	508	lb /ft	7.2	8.6	10.2	11.8	13.5	17	20.8	24.8
			kg/m	34	37	41	44	52	60	69	78
28,0	700	711	lb /ft	10.0	12.0	14.0	16.2	18.4	22.9	27.8	32.9
			kg/m	34	37	41	44	52	60	69	78
planar surface			lb /ft ²	1.3	1.6	1.8	2.1	2.3	2.8	3.3	3.8
			kg/m ²	15	16	17	18	20	22	24	26

1.2 Insulation of piping

1.2.5 Cladding (jacketing)

Suitable cladding (jacketing) should be applied to protect the insulation from weather influences, mechanical loads and (potentially corrosive) pollution. Selecting the appropriate cladding depends on various factors, such as working loads, foot traffic, wind and snow loads, ambient temperatures and conditions.

Note

An insulation system resistant to foot traffic must not become permanently damaged if a person weighing 220 lbs (100 kg), (weight including any tools being carried) walks across it. It is not designed to bear additional loads, such as the placing of heavy equipment. For the purpose of the safety regulations, a durable insulation is not considered to be a walkable surface!

When selecting the appropriate cladding (jacketing), take the following points into account:

- As a general rule, galvanised steel is used in buildings due to its mechanical strength, fire resistance and low surface temperature

(in comparison to an aluminium cladding (jacketing)).

- Aluminium is used outdoors, because it is easy to fit and more cost-effective than stainless steel and does not tend to corrode under common weather conditions.
- In corrosive environments, aluminised steel, stainless steel or glass reinforced polyester is used as cladding (jacketing). Stainless steel is recommended for use in environments with a fire risk.
- The surface temperature of the cladding (jacketing) is influenced by the material type. The following applies as a general rule: the shinier the surface, the higher the surface temperature.
- To exclude the risk of galvanic corrosion, only use combinations of metals that do not tend to corrode due to their electrochemical potentials (also see page 22 in section 1.1).
- For acoustic insulation, a noise absorbent material (bitumen, mylar foil) is mounted on the insulation or inside the cladding (jacketing). To reduce the risk of fire, limit the surface temperatures of the cladding (jacketing) to the maximum operating temperature of the noise absorbent material.

Cladding (jacketing) material	Areas at risk of fire	Corrosive environment	Max. surface temperature		
			< 120°F (50°C)	< 140°F (60°C)	> 140°F (60°C)
Aluminium sheet	-	-			●
Aluminium/zinc coated steel sheet	-	-			●
Galvanised steel sheet	●	-			●
Austenitic stainless steel sheet	●	●			●
Aluminised steel sheet	●	●			●
Plastic-coated steel or aluminium	-	-		●	
Glass fibre-reinforced polyester	-	●			< 190°F (90°C)
Coatings/mastics	-	-			175°F (80°C)
Foils	-	-	●		

The thickness of the metal sheet depends on the pipe diameter, type of the metal and type of insulation (rigid or non-rigid insulation according to ASTM). With special acoustic requirements, a larger thickness [> 0.04" (1 mm)] is generally used.

Recommended sheet thickness and overlaps regarding cladding (jacketing) made from flat sheets (conform CINI)

External diameter of the insulation (mm)		Minimum thickness of metal cladding (jacketing) sheet (recommended by CINI)									
		Aluminium (CINI 3.1.01)		Aluminised steel sheet (CINI 3.1.02)		Alu-Zinc coated steel sheet (CINI 3.1.03)		Zinc coated steel sheet (CINI 3.1.04)		Austenitic stainless steel sheet (CINI 3.1.05)	
inch	mm	inch	mm	inch	mm	inch	mm	inch	mm	inch	mm
< 5.5"	< 140	0.024	0.6	0.022	0.56	0.020	0.5	0.020	0.5	0.020	0.5
5" to 12"	130-300	0.031	0.8	0.031	0.8	0.031	0.8	0.031	0.8	0.031	0.8
>12"	> 300	0.039	1.0	0.031	0.8	0.031	0.8	0.031	0.8	0.031	0.8

The recommended sheet thickness deviates to a certain level per standard/country. The thickness recommended by CINI is shown in the table above. See section 3.2.2 for the thickness according to DIN 4140 and BS 5970.

To reduce the risk of galvanic corrosion, it is very important to use the correct screws, straps etc.

The basic guidelines are:

- Fasten cladding (jacketing) on lengthwise joints with at least six sheet metal screws or blind rivets every metre.
- Place the screws or blind rivets equidistantly. If screws or rivets are fitted in two rows, do not stagger the screws or rivets.
- The cladding (jacketing) can also be held in place with corrosion-resistant straps instead of screws or rivets.
- Do not use aluminium screws.

Influence of the cladding (jacketing) on the surface temperature

In addition to the insulation thickness, the thermal conductivity of the insulation and the ambient conditions (for example temperature and wind), the surface temperature of insulation is also influenced by the emissions ratio of the cladding (jacketing).

The following applies as a general rule for thermal insulation: the shinier a surface is (lower emissivity), the higher the surface temperature. The following example shows the various surface temperatures that depend on the cladding (jacketing):

- Diameter: 4 1/2" (114 mm)
- Temperature of the medium: 930°F (500°C)
- Place of installation: Interior [Wind speed 1.1 mph (0.5 m/s)]
- Insulation: ProRox WM 950, wired mats; thickness: 4" (100 mm)
- Various cladding (jacketing) materials
 - Aluminium sheet
 - Galvanised steel sheet, bright
 - Stainless steel
 - Paint-coated plastic cladding (jacketing)

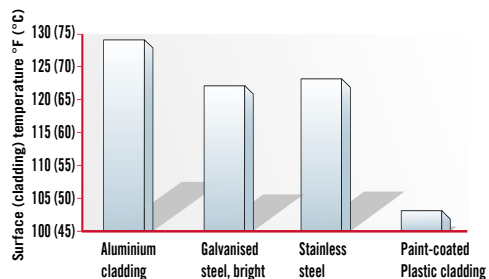



1.2.6 Pipe hangers and pipe supports

There is a wide range of solutions for pipe hangers and pipe supports. The following illustrations show the possibilities described below for insulation systems:

- Pipe hangers in direct contact with the piping
- Pipe supports in direct contact with the piping
- Pipe supports not in direct contact with the piping (commonly used with cold insulation systems)

Pipe hangers in direct contact with the piping

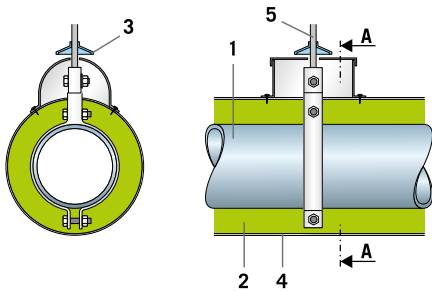

1. Pipe - 2. Insulation: ProRox mandrel wound pipe sections with WR-Tech - 3. Collar - 4. Cladding (jacketing) - 5. Pipe hanger

Pipe support in direct contact with the piping

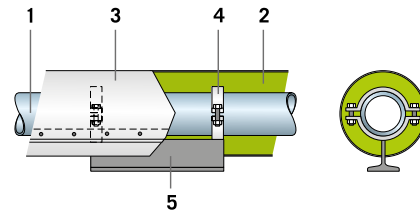

1. Pipe - 2. Insulation: ProRox mandrel wound pipe sections with WR-Tech - 3. Cladding (jacketing) - 4. Pipe clamp - 5. Pipe saddle

Pipe support not in direct contact with the piping

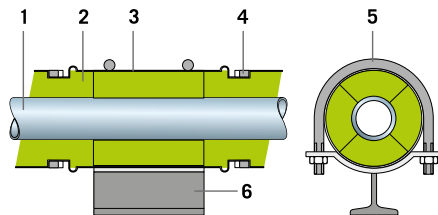

1. Pipe - 2. Insulation: ProRox mandrel wound pipe sections with WR-Tech - 3. Cladding (jacketing) - 4. Seal - 5. Stirrup - 6. Pipe saddle

A basic rule applying to all pipe attachments is that the insulation system [i.e. the insulation and cladding (jacketing)] must not be damaged if the piping expands. Damage to the cladding (jacketing) of outdoor installations, in particular, can allow the ingress of moisture in the material. The result may be permanent damage of the insulation system and as a consequence high heat losses, and dangerously high surface temperatures and corrosion etc.

1.2 Insulation of piping

1.2.7 Insulation of valves and flanges

Heat losses incurred through non insulated fixtures such as valves and flanges are substantial, even at low temperatures. Refer to VDI 4610. As a rough estimation it is also possible to simplify a valve to a pipe with a pipe length of 1 meter. A heat loss calculation of a 1 meter long uninsulated pipe can be done via the thermal calculation program Rockassist. The temperature of the medium can also decrease to such an extent at non-insulated fittings or flanges, that process critical temperatures are reached, at which point for example, the medium will start to crystallise. Valves and flanges should therefore be insulated as much as possible with at least the same insulation thickness as the pipe. To avoid damage during inspection or repairs, the insulation for valves and flanges is designed with removable coverings or hoods, to allow rapid disassembly. Removable coverings or hoods are usually insulated from the inside with wired mats. The coverings are fastened to the object with lever fastenings, which are fixed directly onto the covering or on to straps. Take the following conditions into account when designing insulated coverings for fittings and flanges:

- The overlap distance of the insulated covering over the insulated pipe should be at least 2" (50 mm).
- The pipe insulation should end at the flanges, leaving a gap equal to the bolt length + 1.2" (30 mm) and should be closed off with a lock washer so the flange can be loosened without damaging the insulation.
- With valves, an extended spindle should preferably be fitted horizontally or below the pipe to prevent leakage along the spindle shaft.
- The cladding (jacketing) must be fitted to prevent the ingress of moisture in the insulation. On inclined or vertical piping, for example, mount rain deflectors above the removable coverings. If the ingress of moisture into the insulation is unavoidable, make 0.4" (10 mm) diameter drain holes in the removable covering.
- The air gap between valves and the insulation can be filled up with ProRox LF 970 to further reduce heat losses caused by convection.

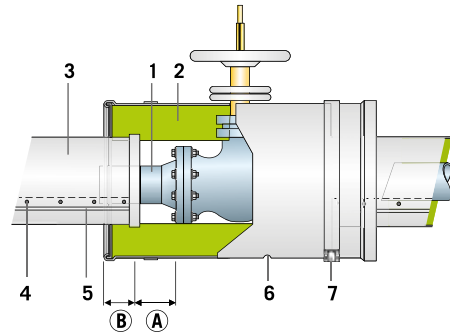

1. Pipe - 2. ProRox insulation -
3. Cladding (jacketing) - 4. Sheet-metal screw or rivet with EPDM gaskets - 5. Swage - 6. Drainage opening -
7. Strap - (B) $\geq 2"$ (50 mm) - (A) = bolt length + 1.2" (30 mm)

A number of possible design options for insulation systems for pipe fittings and flanges follow:

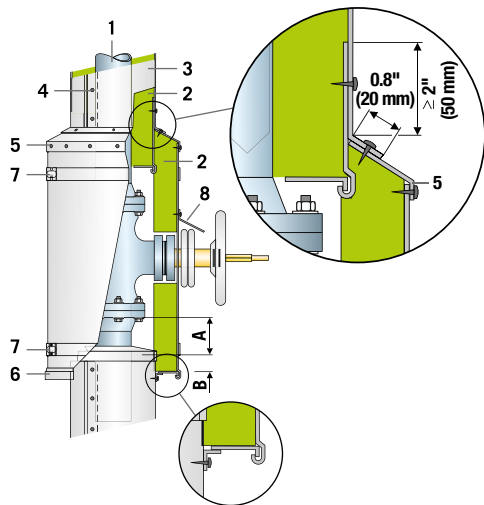

1. Pipe - 2. ProRox insulation -
3. Cladding (jacketing) - 4. Sheet-metal screw or rivet with EPDM gaskets - 5. Rain deflector - 6. Lock washer -
7. Straps - 8. Rain deflector -
- (B) $\geq 2"$ (50 mm) - (A) = bolt length + 1.2" (30 mm)

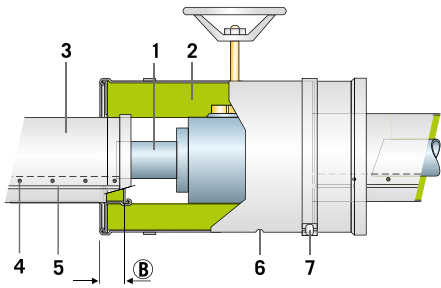

1. Pipe - 2. ProRox insulation - 3. Cladding (jacketing) - 4. Sheet-metal screw or rivet - 5. Swage - 6. Drainage opening - 7. Straps - $\textcircled{B} \geq 2"$ (50 mm)

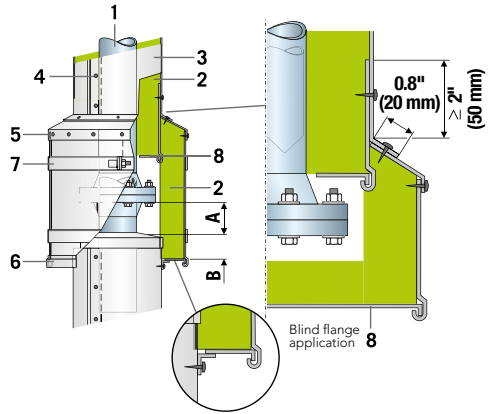

1. Pipe - 2. ProRox insulation - 3. Cladding (jacketing) - 4. Sheet-metal screw or rivet - 5. Rain deflector - 6. Lock washer - 7. Straps - 8. Lock washer - $\textcircled{B} \geq 2"$ (50 mm) - $\textcircled{A} = \text{Screw length} + 1.2"$ (30 mm)

Leakages

With pipes where a leaking fluid content could damage the insulation or the coating system, we recommend to mount flange straps with a leak detection fitting around the flange. Flange bands can also prevent flammable products from penetrating into the insulation material and can help prevent the outbreak of fire, for example in case of thermal oil pipelines.

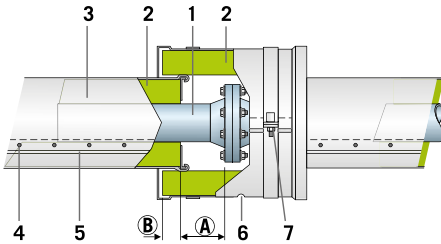

1. Pipe - 2. ProRox insulation - 3. Cladding (jacketing) - 4. Sheet-metal screw or rivet - 5. Swage - 6. Drainage opening - 7. Straps - $\textcircled{B} \geq 2"$ (50 mm) - $\textcircled{A} = \text{Bolt length} + 1.2"$ (30 mm)

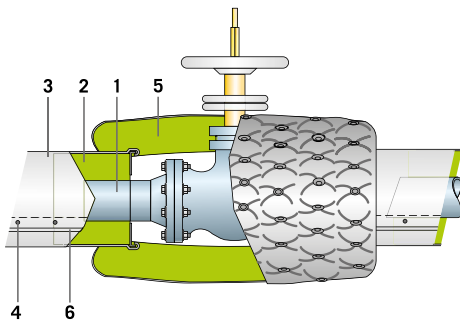

1. Pipe - 2. ProRox insulation - 3. Cladding (jacketing) - 4. Sheet-metal screw or rivet - 5. Removable coverings (insulated from the inside - 6. Swage

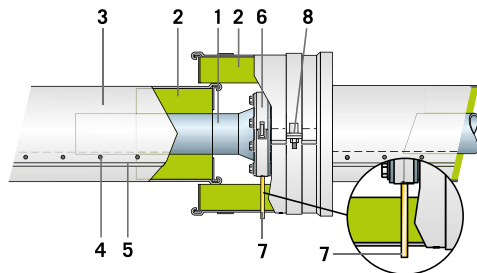

1. Pipe - 2. ProRox insulation - 3. Cladding (jacketing) - 4. Sheet-metal screw or rivet - 5. Swage - 6. Flange band - 7. Leak detection fitting - 8. Clamps

1.2 Insulation of piping

1.2.7 Insulation of valves and flanges

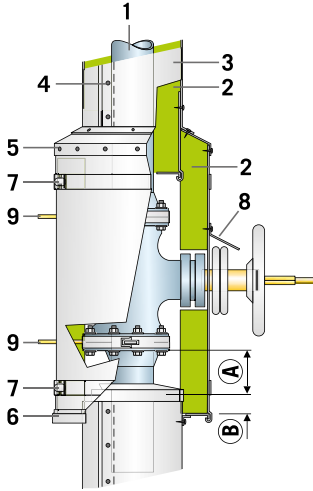

1. Pipe - 2. ProRox insulation - 3. Cladding (jacketing) - 4. Sheet-metal screw or rivet - 5. Collar - 6. Collar - 7. Clamps - 8. Rain deflector - 9. Leak detection fitting - $\text{B} \geq 2"$ (50 mm) - $\text{A} = \text{bolt length} + 1.2"$ (30 mm)

1.2.8 Insulation of pipe elbows and T pieces

The cladding (jacketing) of elbows and T-pieces is susceptible to damage, due to expanding or vibrating pipes. There is a particular risk of moisture penetrating damaged swage connections in the cladding, if the object is located outdoors.

For the insulation of shaped pieces, we recommend using the same insulation in the same thickness as used for the pipe.

Insulation of pipe elbows with ROCKWOOL mandrel wound pipe sections

For the insulation of pipe elbows with mandrel wound pipe sections with WR-Tech (e.g. ProRox PS 960), the pipe sections are cut into segments and tightly fitted onto the pipe elbow with the lengthwise joints facing downwards. The angular

division of the segments should correspond to the radius of the pipe elbow. The mandrel wound pipe section segments are fastened to the pipe elbow with clamps or binding wire. Joints between the individual segments are plugged tightly with ProRox loose fill.

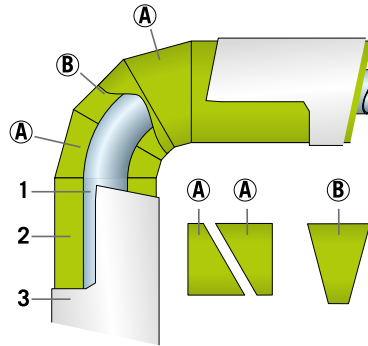

1. Pipe - 2. Insulation: ProRox mandrel wound pipe sections with WR-Tech - 3. Cladding (jacketing) - A and B = Segmented mandrel wound pipe sections

Insulation of pipe elbows with wired or load bearing mats (wrap)

If the piping is insulated with wired mats or load bearing mats (wrap), shaped pieces such as pipe elbows or T-pieces are generally insulated with the same mats (wrap). In this case, the mats (wrap) are cut into so-called fish-shaped elbow segments. These are mounted onto the pipe elbow to seal the elbow. With wired mats, all the joints (both circular and lengthwise joints) are sewn together with binding wire or mat (wrap) hooks. Spacers are required at least at the start and end of the elbow (for more details, please see page 38).

Load-bearing mats (wrap) are fixed to the pipe elbow with metal or plastic straps. Any gaps between the individual segments are plugged up with ProRox loose fill. Secure the joint edges with self-adhesive aluminium tape.

The diagrams below show how the sheet is mounted onto shaped pieces.

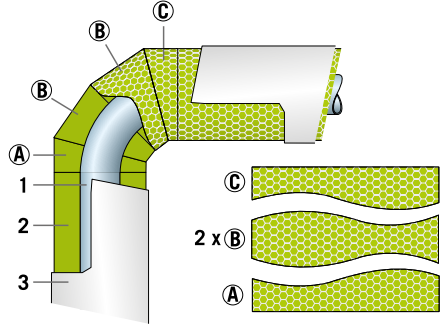

1. Pipe - 2. ProRox insulation - 3. Cladding (jacketing) -
 Ⓐ to Ⓒ: Elbow segments of mats (wrap)

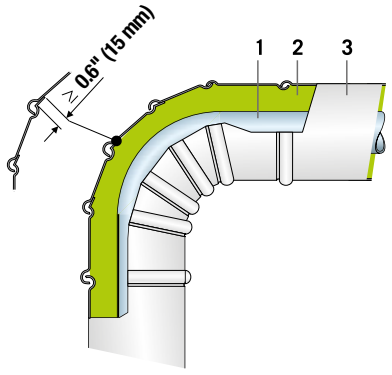

1. Pipe - 2. ProRox insulation - 3. Cladding (jacketing)

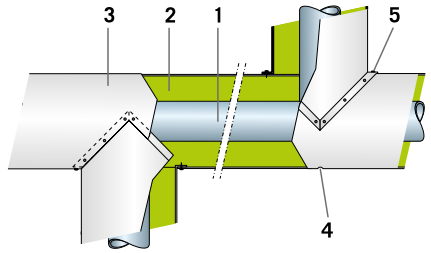

1. Pipe - 2. ProRox insulation - 3. Cladding (jacketing) -
 4. Drainage opening - 5. Edging with mastic compound

1.2.9 Reducers

Pipes that branch out with many outlets reduce the pipe diameter. Examples of how to install reducers follow:

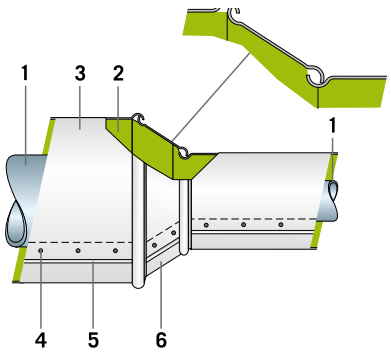

1. Pipe - 2. ProRox insulation - 3. Cladding (jacketing) -
 4. Sheet-metal screw or rivet - 5. Swage - 6. Reducer

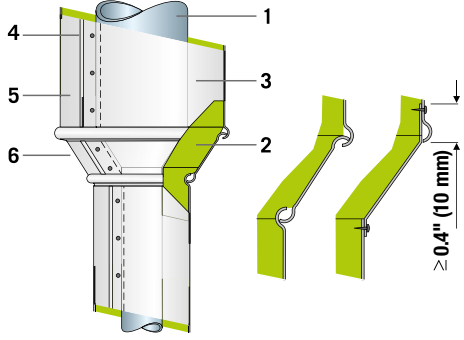

1. Pipe - 2. ProRox insulation - 3. Cladding (jacketing) -
 4. Sheet-metal screw or rivet - 5. Swage - 6. Reducer

1.2 Insulation of piping

1.2.10 Expansion joints

In thermal insulation systems, large differences between the piping and the cladding (jacketing) temperature can occur. The materials used for the pipe, insulation, insulation support and cladding (jacketing) also have different thermal expansion coefficients. This leads to different thermal elongations of the various components in the insulation system, which must be allowed for using constructive measures. The elongation " Δl " can be determined as follows:

$$\Delta l = l \cdot \Delta t \cdot \alpha$$

In this formula, "l" corresponds to the length of the pipe, " Δt " corresponds to the difference in temperature between the cold and warm pipe (or cladding) and " α " corresponds to the linear thermal expansion coefficient (see tables in chapter 3).

If bellow expansion joints for thermal length compensation have been built into the pipe, the insulation system bellows, thereby compromising the compensatory effect. The expansion bellows are covered with a sheet that is then insulated (see diagram). With temperatures above 550°F (300°C), do not use galvanised sheets due to the risk of galvanic corrosion (cracking).

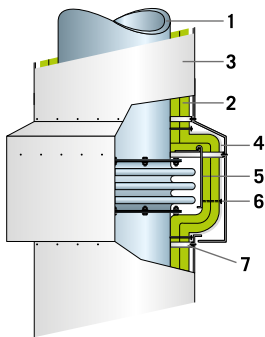

1. Pipe - 2. ProRox insulation - 3. Cladding (jacketing) -
4. Aluminium foil - 5. Cover sheet -
6. Mat (wrap) pin with clip - 7. Spacer

To compensate for thermal expansion of the cladding (jacketing), install the expansion joints shown below.

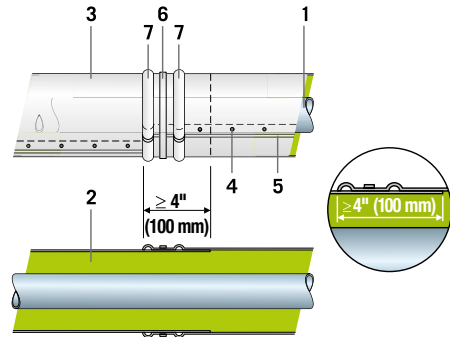

1. Pipe - 2. ProRox insulation - 3. Cladding (jacketing)
- 4. Sheet-metal screw or rivet - 5. Swage -
6. Metal strap - 7. Circumferential seam

1.2.11 Tracing

When media are transported over long distances, in particular, the media inside the piping can spoil, set or be at risk from frost in the winter. Insulation can reduce heat losses and postpone the moment at which the installation freezes. Insulation alone, however, cannot indefinitely prevent the installation from freezing. Installing additional tracing may be necessary between the object and the insulation.

A distinction is made between pipe tracing and electrical tracing. In pipe tracing systems, a heating pipe is fitted parallel and close to the media pipe. Steam, warm water or thermal oil flows through the tracing pipes as a heat transfer medium. Electrical tracing consists of cables mounted onto the pipes. These cables heat the pipes.

Traced pipes can be insulated with ProRox mandrel wound pipe sections with WR-Tech or load bearing mats (wrap). Ensure that no insulation occupies the space between the tracing and the pipe; otherwise the heat transfer will be hampered. Pipes and heat tracing are therefore often wrapped in aluminium foil. If ProRox mandrel wound pipe sections are used, select a correspondingly larger internal diameter of the mandrel wound pipe section. With vertical piping, sealing the end of each mandrel wound pipe section with ProRox loose fill is recommended to prevent convection (chimney effect).

The electric heat cable metal sheath and metal foil must be electro-chemically compatible and it may be necessary to use other foils than aluminum. Use the selection table for proper cable metal and foil metal combination.

Foil wrap selection table

Electrical heat cable sheath metal	Metal foil wrap
Aluminum	Aluminum
Copper	Copper
Nickel-Chrome Alloy Steel	Copper

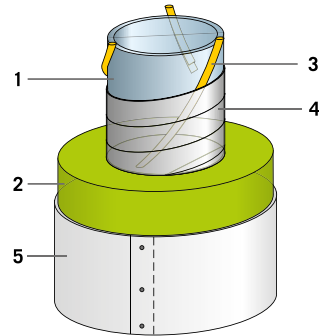

1. Pipe - 2. Insulation: ProRox mandrel wound pipe sections with WR-Tech - 3. Electrical tracing - 4. Aluminium foil - 5. Cladding (jacketing)

The diagrams on the right show various design options.

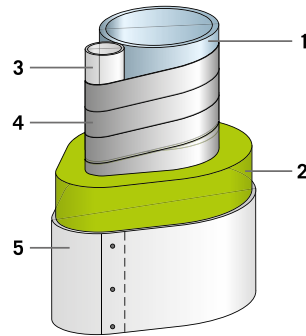

1. Pipe - 2. Insulation: ProRox load bearing mats (wrap) or wired mats - 3. Tracing - 4. Aluminium foil - 5. Cladding (jacketing)

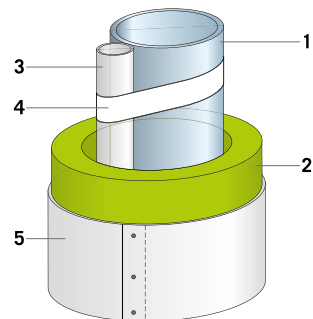

1. Pipe - 2. Insulation: ProRox mandrel wound pipe sections with WR-Tech - 3. Tracing - 4. Binding tape - 5. Cladding (jacketing)

1.2 Insulation of piping

1.2.12 Foot traffic

Avoid walking on insulated pipes, as this can damage the insulation. Damage caused by foot traffic includes dented cladding (jacketing) and gaps at the sheet seams. Water can penetrate the insulation through these gaps and cause lasting damage to the entire insulation system. The result is often greater heat losses and corrosion.

Note

An insulation system resistant to foot traffic must not become permanently damaged if a person weighing 220 lbs (100 kg), (weight including any tools being carried) walks on it. It is not designed to bear additional loads, such as the placing of heavy equipment. For the purpose of the safety regulations, a durable insulation is not considered to be a walkable surface.

In special applications, reinforcing the cladding (jacketing) is recommended, e.g. using a reinforcement sheet. Pipe insulation systems resistant to foot traffic require an insulation material with a high mechanical strength (e.g. ProRox PS 970 or ProRox PS 980 mandrel wound pipe sections with WR-Tech). Using other insulation materials such as wired mats, which are not resistant to pressure, is not recommended, as the cladding (jacketing) only rests on the spacers and tends to dent when walked upon.

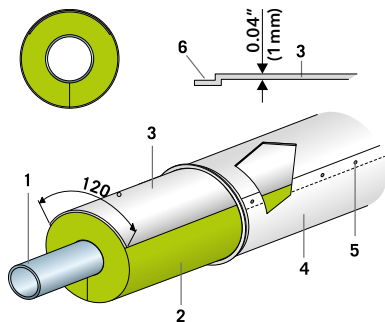

1. Pipe - 2. Insulation: ProRox PS 970 or ProRox PS 980 -
3. Reinforcement sheet - 4. Cladding (jacketing) -
5. Sheet-metal screw or rivet - 6. Joggle

1.2.13 Non-contact insulation for CUI (corrosion under insulation) mitigation

Non-contact insulation in combination with ProRox mandrel wound pipe sections with WR-Tech, is probably one of the best CUI-mitigation insulation systems for carbon/mild steel pipes and equipment. The idea is to create an annular gap between the insulation material and the steel pipe, so when water gets into the system it can run off/evaporate from the steel surface. It is moved by gravity or migrate as water vapour to the cladding (jacketing), where it can run to a lower point and be drained off – through a drain hole or special drain plugs.

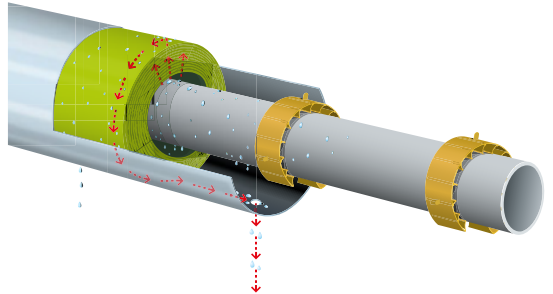

The gap/void between the steel pipe and the insulation prevents water entrapment at the steel/insulation interface and allows the steel surface to dry. This reduces time of wetness and so also the rate of corrosion of unprotected steel. The reduced time of wetness is also beneficial to the coating system and will extend the lifetime of this primary corrosion protection.

Non-contact insulation works best with an insulation material that allows water vapour to move freely – as stone wool does. Various spacer systems (metallic and polymeric) for non-contact insulation are available on the market. For thermal calculations with regard to non-contact insulation systems, the annular gap/void created by the spacer system must be included in the calculation of the outer pipe diameter (pipe diameter for calculation = actual pipe diameter + 2x gap/void).

1.2.14 Acoustic solutions

We are constantly surrounded by unwanted sound (noise). Today, clinical studies have proven that people exposed to high noise levels will face increased risk of cardiac diseases and their general stress threshold is significantly lowered. Fatigue, which can be seen in industry, at sea and offshore, is a serious safety issue for a large range of operators.

Noise can be generated by plant, equipment or the processing of fluids and/or gasses. It can originate from the following:

- Flow induced turbulence
- Cavitation and flashing
- Pumps and compressors
- Pressure fluctuations
- Valves or other pressure reducing devices
- Change of pipe diameter

ROCKWOOL stone wool has an open fibre structure, which is ideal for the absorption and regulation of sound. ROCKWOOL Technical Insulation can provide a full range of products and solutions to reduce the noise levels of technical installations. The nature and effect of the sound insulation depend on the frequency and the sound pressure level.

ISO 15665 is the standard that is widely accepted in the industry for designing the acoustic insulation of pipes valves and flanges. ISO 15665 sets out classes for acoustic pipework insulation system.

ProRox solutions for pipe diameters < 12" (300 mm) (according to ISO 15665:2003)

Insulation	Thickness	Mass layer	Cladding	Class A1	Class B1	Class C1
ProRox PS 960	4" (100 mm)	-	Metal sheet*	+	+	+
ProRox PS 960	4" (100 mm)	21 lb/yd ² (≥ 8 kg/m ²)	Fiberglass reinforced polyester wrap**	+	+	+
ProRox WM 950	4" (100 mm)	-	Metal sheet*	+	+	+
ProRox PS 970	4" (100 mm)	-	Metal sheet*	-	+	-
ProRox MA 520 ALU	2*2" (2*50 mm)	-	Metal sheet*	-	+	-
ProRox PS 960	2" (50 mm)	-	Metal sheet*	-	+	-

*The weight of the metal cladding (jacketing) should be approx. 20.6 lb/yd² (7.8 kg/m²). As a general guidance we recommend using a 0.04" (1 mm) steel cladding (jacketing).

**The weight of fiberglass reinforced polyester wrap should be approx. 8 lb/yd² (3.2 kg/m²).

1.2 Insulation of piping

ProRox solutions for pipe diameters 12"-25" (300-650 mm) (according to ISO 15665:2003)

Insulation	Thickness	Mass layer	Cladding	Class A2	Class B2	Class C2
ProRox PS 960	4.7" (120 mm)	-	Metal sheet*	+	+	+
ProRox PS 960	4.7" (120 mm)	21 lb/yd ² (≥ 8 kg/m ²)	Fiberglass reinforced polyester wrap**	+	+	+
ProRox WM 950	4.7" (120 mm)	-	Metal sheet*	+	+	+
ProRox PS 970	4" (100 mm)	21 lb/yd ² (≥ 8 kg/m ²)	Metal sheet*	-	+	-
ProRox PS 960	4" (100 mm)	21 lb/yd ² (≥ 8 kg/m ²)	Fiberglass reinforced polyester wrap**	+	+	+
ProRox MA 520 ALU	4" (100 mm)	-	Metal sheet*	-	+	-
ProRox PS 960	4" (100 mm)	-	Metal sheet*	-	+	-

*The weight of the metal cladding (jacketing) should be approx. 20.6 lb/yd² (7.8 kg/m²). As a general guidance we recommend using a 0,04" (1 mm) steel cladding (jacketing).

**The weight of fiberglass reinforced polyester wrap should be approx. 8 lb/yd² (3.2 kg/m²).

ProRox acoustic solutions with mandrel wounded pipe sections

The sections are supplied split and hinged for easy snap-on assembly. Depending upon the acoustic demands, this solution can be equipped with an additional heavy mass layer and/or a waterproof insulation protection, fiberglass reinforced polyester.

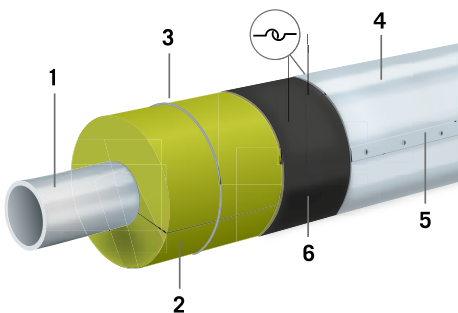

1. Pipe - 2. Insulation: ProRox mandrel wound pipe sections with WR-Tech - 3. Steel band or binding wire - 4. Cladding (jacketing) - 5. Sheet-metal screw or rivet - 6. Heavy mass layer (if required)

ProRox acoustic solutions with wired mats

ProRox wired mats are lightly bonded stone wool mats (wrap) stitched on galvanised wire mesh using galvanised wire ensuring an optimal flexibility. Depending upon the acoustic demands, this solution can be equipped with an additional heavy mass layer.

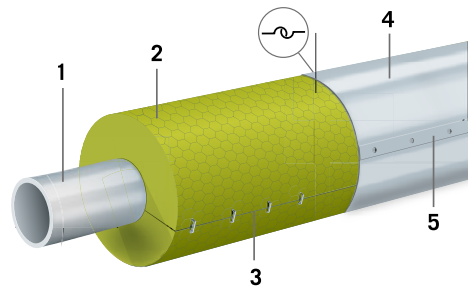

1. Pipe - 2. Insulation: ProRox wired mat - 3. Joint edges closed with e.g. mat (wrap) hooks or binding wire - 4. Cladding (jacketing) - 5. Sheet-metal screw or rivet

Advantages:

- Outstanding acoustic performance as well providing excellent thermal benefits
- Easy and quick to handle and install: thermal insulation, maximum 1 heavy mass layer and metal cladding (jacketing) does the job (maximum 3 layers)
- Commercially available products: As a standard we can offer a wide range of diameters and insulation thicknesses
- Watertight finish is possible in combination with fiberglass reinforced polyester (watertight insulation protection)
- Long lasting: natural product made out of stone
- Open to vapor: ingressed moisture can evaporate out of the system
- Excellent fire behaviour: ProRox insulation is tested in accordance with EN 13501, ASTM E84, IMO Res. A.653.
- Open fiber structure that readily absorbs sound

1.2 Insulation of piping

1. System solutions

1.3 Insulation of vessels

Vessels are a major component in installations for various procedures in almost all fields of industry.

Many production processes require different substances that are stored in vessels and used in the individual processes later in the procedure. The vessels primarily store liquid, solid or gaseous substances, which are added to the process as and when required. Raw materials, fuels or end products are usually stored in large storage tanks.

It is often important to store the substances within certain temperature limits. If the temperature is too high or too low, the substance can spoil or set, or lose its flowing properties and become incapable of being pumped or discharged. Insulation is therefore a major factor in the functionality of procedural processes. It also has the following purposes:

- Reduces heat losses
- Guarantees protection against contact by minimising the surface temperature
- Reduces cooling of the stored substance, so it remains fluid and does not set
- Prevents the vessel from freezing (with additional tracers)
- Prevents heating of the stored substance (for example, through solar radiation)

The vessels used in the different industrial processes are so varied that the examples of use cannot fully take into account the particular circumstances of each case.

Determine whether the products and construction described are suitable for the corresponding application in each individual case. If in doubt, consult the ROCKWOOL Technical Insulation sales team.

The applicable standards and regulations must also be observed. A few examples follow:

- ASTM C1696 "Standard Guide for Industrial Insulation Systems"
- NACE SP0198 (Control of corrosion under thermal insulation and fireproofing materials - a system approach)

- ASME "Boiler and Pressure Vessel Code"
- MICA "National Commercial & Industrial Insulation Standards"
- DIN 4140 (Insulation works on industrial plants and building services installations)
- AGI Q05 (Construction of industrial plants)
- AGI Q101 (Insulation works on power plant components)
- CINI-Manual: "Insulation in industry"
- BS 5970 (Code of practice for thermal insulation of pipe work, equipment and other industrial installations) PIP (Process Industry Practices)

Before starting the insulation works, ensure that all preparatory work on the object has been completed. Refer to Chapter 1.1 for details.

Insulation systems for vessels

An insulation system for a vessel generally consists of the following components:

- Insulation
- Support construction and a spacer
- Water vapour retarder with cold insulation systems
- Cladding (jacketing)

The actual operating temperature (above or below ambient) is essential for the design of the insulation work. The following chapters concentrate on hot insulation.

1.3 Insulation of vessels

Selection and installation of the insulation

Selecting the appropriate insulation depends on the operating method, the installation temperature, the dimensions and the location of the vessel.

Typical insulation materials are ProRox load bearing mats (wrap) like ProRox MA 520 ALU or ProRox MA 960, and ProRox flexible and semi-rigid slabs (board) like the ProRox SL 930.

Since vessels are often located outdoors, it is important to select insulation with a low thermal conductivity and excellent water repellent properties. The insulation is usually fastened to the cylindrical vessels with steel straps. These should be made from stainless steel and should be closed with butterfly nuts or quick release fasteners. The strap measurements and intervals for cylindrical objects shown in the table on the next page have proved useful in many projects.

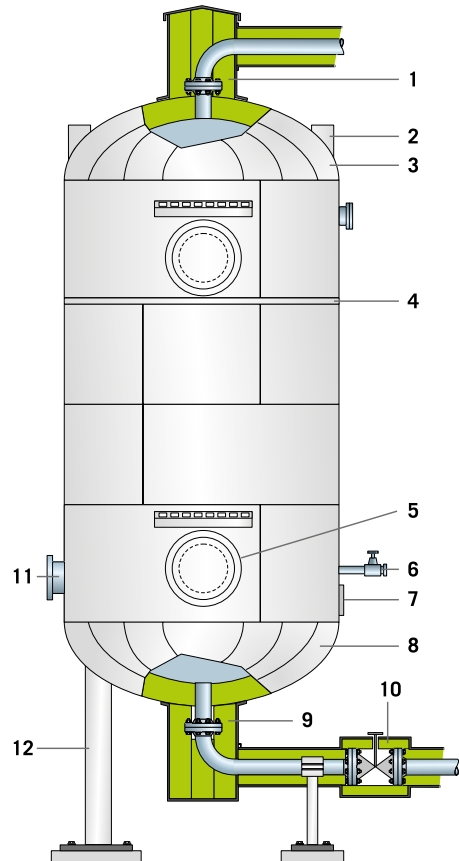

1. Vessel inlet - 2. Crane hooks - 3. Vessel head -
4. Expansion joint - 5. Manhole - 6. Tapping point -
7. Identification board - 8. Vessel base - 9. Vessel outlet
- 10. Fitting insulation - 11. Flange - 12. Vessel leg

Minimum radius ROCKWOOL ProRox slabs (boards)								
Product	Unit	Insulation thickness						
		1.5 inches 40 mm	2.0 inches 50 mm	2.5 inches 60 mm	3.0 inches 70 mm	3.5 inches 80 mm	4.0 inches 100 mm	5.0 inches 120 mm
ProRox SL 930	inches	22	32	42	60	66	76	100
	mm	500	700	1000	1200	1500	1900	2400
ProRox SL 960	inches	30	48	66	92	100	100	100
	mm	700	1000	1500	2000	2500	2500	2800

Following the CINI guidelines, every layer of slab insulation shall be separately fastened with stainless steel bands of min. (0.5" x 0.02") 13 x 0.5 mm at (12") 300 mm intervals.

If the insulation is assembled in multiple layers, the joints of the individual insulation layers must be staggered (so called masonry bond).

Load bearing mats (wrap) as ProRox MA 520 ALU, ProRox MA 960 NA are usually used for horizontal applications, semi-rigid slabs (board) like ProRox SL 930 are usually used to insulate vessels with flat vertical walls. In this case, the insulation is attached with welding pins and spring plates. On flat surfaces, attach the wired mats using minimum six pins per m², and minimum ten pins per m² on the underneath. Observe the following when pinning the insulation:

- With insulation thicknesses ≤ 5" (120 mm), use 8 gauge (GA) / 6 American wire gauge (AWG) pins with a minimum diameter of 0.162" (4 mm).
- With insulation thicknesses ranging from 8GA (6AWG) pins with a minimum diameter of 0.162" (4 mm).
- With insulation thicknesses ≥ 10" (240 mm) use 4GA (3AWG) pins with a minimum diameter of 1/4" (6 mm).
- If the cladding (jacketing) rests directly on the insulation without a gap between the two, the pins must be 3/8" (10 mm) shorter than the insulation thickness.
- Fasten each insulation layer with straps and clips.

With wired mats, all the lengthwise and crosswise joints must be sewn or wired together, or joined with six mat (wrap) hooks per metre. If the insulation is assembled in multiple layers, the joints of the individual insulation layers must be staggered.

The following illustrations show a number of typical methods of insulating vessels.

Insulation of a crane hook

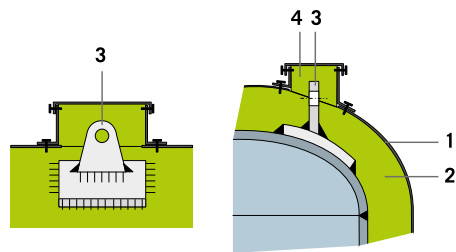

1. Cladding (jacketing) - 2. ProRox insulation - 3. Crane hooks - 4. Insulation covering for the crane hook

1.3 Insulation of vessels

Selection and installation of the insulation

Insulation of a vessel base

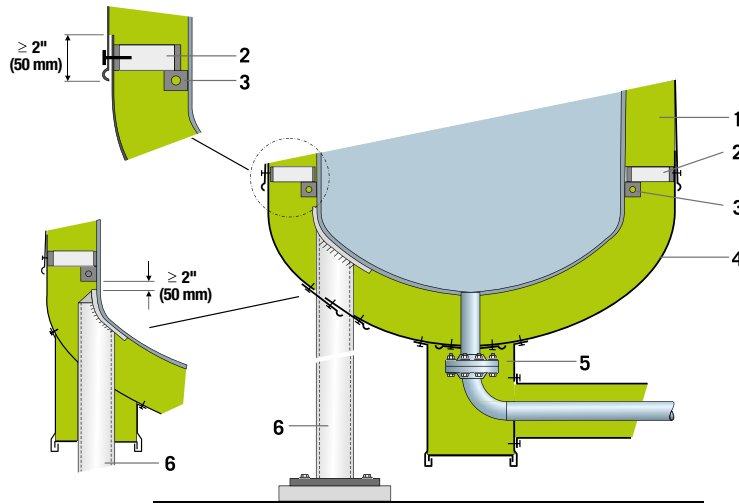

- 1. ProRox insulation - 2. Support construction - 3. Mounting support - 4. Conical column head - 5. Vessel outlet - 6. Vessel leg

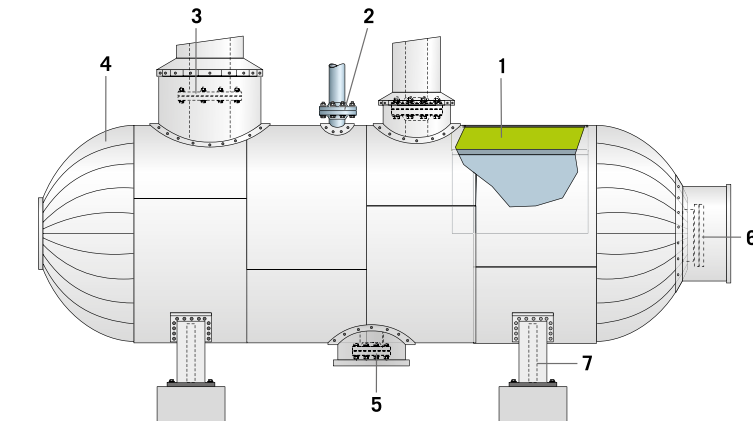

- 1. ProRox load bearings mats (wrap) - 2. Flange inlet for safety valve - 3. Vessel filling nozzles - 4. Conical head - 5. Vessel drawdown - 6. Conical head with manhole - 7. Vessel leg

Insulation of a conical head

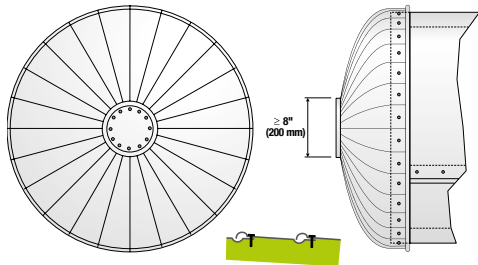

Insulation of a conical head with a manhole

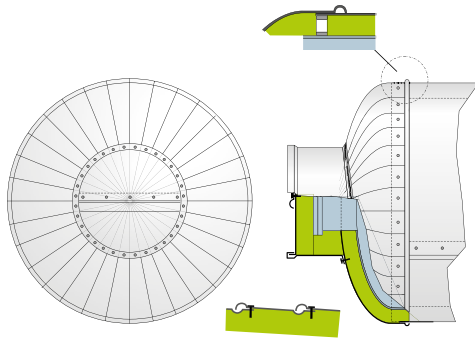

Insulation of vessel outlet

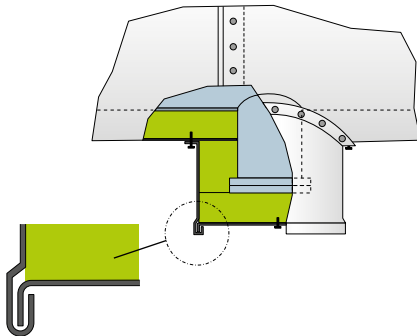

Support constructions and spacers

The application of support constructions and spacers on vessels is essential. The objective of support constructions is to bear the weight of the insulation system and to bear the weight above mounting supports on the object to be insulated. The spacers keep the cladding (jacketing) of the insulation at a predetermined distance. On vertical vessels, the substructures often assume the function of the support construction and spacer. The design specifications are illustrated in Chapter 1.2.4 The corresponding requirements for support constructions and spacers can be found in CINI, the AGI guidelines Q153 and 154 and MICA National Insulation Standards.

Before commencing the insulation works, fit mounting supports to the vessels to which the support constructions are fitted. The shape, construction and measurements of mounting supports for support constructions must enable the insulation to be fitted during assembly. Use the design loads specified in DIN guidelines 1055-4 and 1055-5 to dimension the mounting supports and the support constructions and spacers.

Cladding (jacketing)

The cladding (jacketing) of vessels protects the insulation against mechanical influences and the weather. There is a wide range of different flat and profiled sheets available. See Chapter 3.2 for an overview. Flat sheets are primarily used to clad smaller vessels. With large-scale insulation systems, flat sheets can only bear small, static loads exerted by the wind. It is therefore essential to reduce the distance between the support structures.

The result will be a higher number of support structures and thermal bridges. On large surfaces, flat sheets are more likely to buckle or dent, leading to optical damages, than profiled sheets. To improve the stability and optical characteristic, the sheets can be canted diagonally (cambered).

1.3 Insulation of vessels

Cladding (jacketing)

Preferably use profiled sheets for vessels with a large surface area. They offer structural advantages and can accommodate expansions that are perpendicular to the direction of the swage. The disadvantage is that pipe protrusions are more complex from a structural perspective. Using profiled sheets is only recommended with cladding (jacketing) with a low number of protrusions.

Design profiled sheet casings so that rainfall is deflected safely.

Cladding (jacketing) in moist or corrosive environments

To guarantee the functionality of a technical insulation, it is important to protect it against atmospheric influences and prevent the ingress of moisture into the insulation. Moisture in the insulation system increases thermal conductivity, thereby reducing the effectiveness of the thermal protection. It also represents a high risk of corrosion to the component. In certain applications, the cladding (jacketing) system is also expected to offer chemical resistance, as well as being resistant to cleaning methods such as steam blasting. Alongside the insulation and construction, selecting a suitable cladding (jacketing) system is very important as it forms the basis for a long service life, low maintenance costs and low heat loss of a technical insulation.

1. System solutions

1.4 Insulation of columns

Columns are pillar-shaped vessels, which are mainly used in the petrochemical industry for distillation or the extraction of substances. They often form the key elements in chemical or petrochemical plants. The processes in columns often only operate at certain temperatures. The insulation of columns plays an important role in their functionality.

- Reduces heat losses
- Guarantees protection against contact by minimising the surface temperature
- Reduces the cooling of the stored substance, so it remains fluid and does not set
- Ensures the column remains at the necessary process temperatures
- Prevents heating of the stored substance (for example, through solar radiation)

The columns used in the different industrial processes are so varied that the examples of use below cannot fully take into account the particular circumstances of the construction-related factors. Determine whether the products and construction described are suitable for the corresponding application in each individual case. If any doubt, consult the ROCKWOOL Technical Insulation sales team.

The applicable standards and regulations must be observed. A few examples follow:
add:

- ASTM C1696 "Standard Guide for Industrial Insulation Systems"
- NACE SP0198 (Control of corrosion under thermal insulation and fireproofing materials - a system approach)
- ASME "Boiler and Pressure Vessel Code"
- MICA "National Commercial & Industrial Insulation Standards"
- DIN 4140 (Insulation works on industrial plants and building services installations)
- AGI Q101 (Insulation works on power plant components)
- CINI-Manual: "Insulation in industry"
- BS 5970 (Code of practice for thermal insulation of pipe work, equipment and other industrial installations) PIP (Process Industry Practices)

Before starting the insulation works, ensure that all preparatory work on the object has been completed. Refer to Chapter 1.1 for details.

Insulation systems for columns

An insulation system for vessels and columns generally comprises the following components:

- Insulation
- Support construction and a spacer
- Water vapour retarder in the case of cold insulation systems
- Cladding (jacketing)

The temperature of the columns, in particular, has a significant impact on the optimal insulation system. This chapter focuses on the insulation of hot columns.

1.4 Insulation of columns

Insulation systems for columns

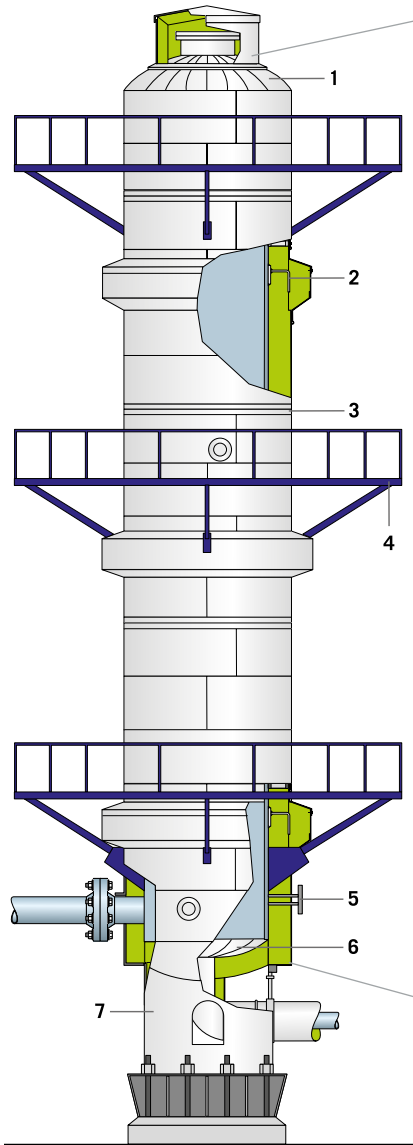

1. Column head - 2. Reinforcement ring - 3. Expansion joint - 4. Working platform - 5. Identification board - 6. Column base - 7. Column skirt

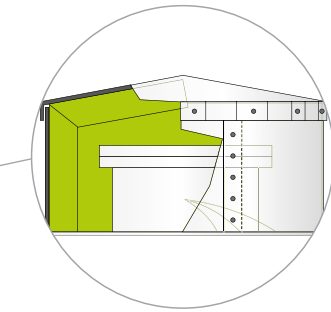

Selection and installation of the insulation

Selecting the appropriate insulation depends on the operating method, the installation temperature, the dimensions and the location of the vessel or column.

Insulation materials like ProRox load bearing mats (wrap) are primarily used for the insulation of columns.

Since columns are often located outdoors, it is important to select insulation with a low thermal conductivity and excellent water repellent properties. The insulation is usually fastened to the columns with steel straps. These should be made from stainless steel and should be closed with butterfly nuts or quick release fasteners. The strap measurements and intervals for cylindrical objects shown in the table on the next page have proved useful in many projects.

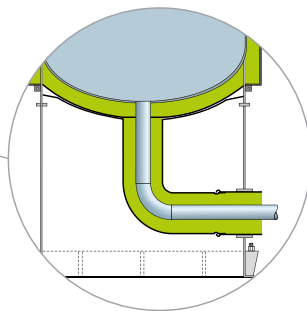

External insulation diameter	Internal insulation layer strap measurement	External or single layer insulation strap measurement	Distance between the straps
8" to 72" (200 to 1800 mm)	1/2" x 0.02" (13 x 0.5 mm)	5/8" x 0.02" (16 x 0.5 mm)	10" (250 mm)
> 72" (1800 mm)	5/8" x 0.02" (16 x 0.5 mm)	3/4" x 0.02" (19 x 0.5 mm)	10" (250 mm)

In a wide variety of applications, these values can only be used as reference values. In each individual case, determine whether different strap measurements and intervals should be used. If the insulation is assembled in multiple layers, the joints of the individual insulation layers must be staggered. The following illustrations show a number of typical methods of insulating columns.

Insulation of a reinforcement ring

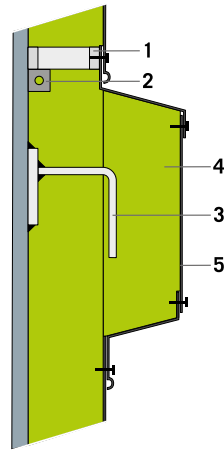

1. Support construction - 2. Mounting support -
3. Reinforcement ring - 4. ProRox insulation -
5. Cladding (jacketing)

Insulation of conical column head

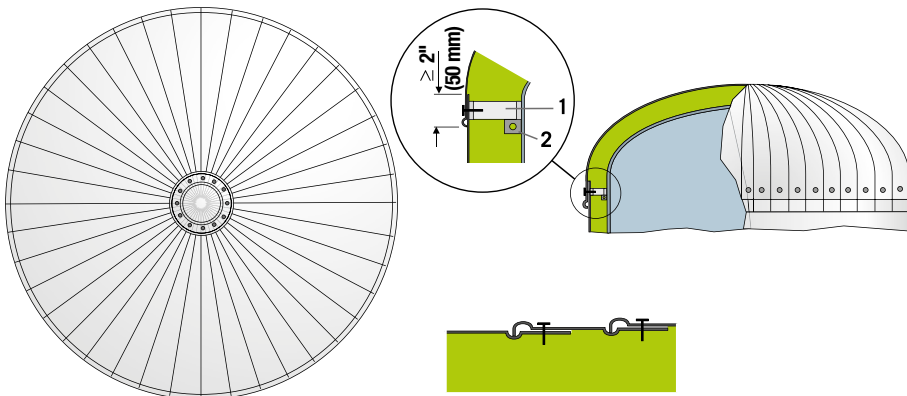

1. Supporting construction - 2. Mounting support

1.4 Insulation of columns

Selection and installation of the insulation

Insulation of a column base

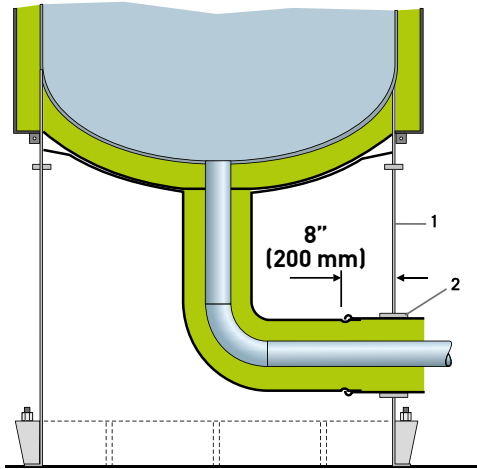

1. Skirt: Column support frame - 2. Sliding cover

Fire protection in column skirts

The fire protection quality of a column primarily depends on the fire resistance of the column support frame. The ROCKWOOL Technical Insulation ProRox solutions offer proven fire protection solutions for column support skirts. If you have any questions, please consult the ROCKWOOL Technical Insulation sales team.

Insulation of manhole on the column head, vertical connection

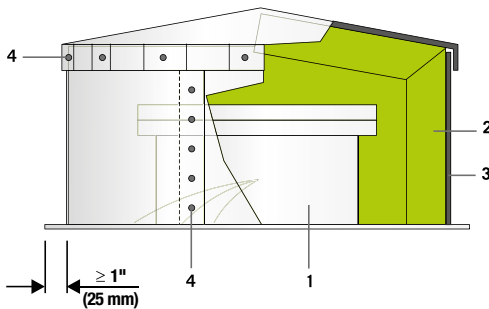

1. Manhole - 2. ProRox insulation -
3. Cladding (jacketing) - 4. Sheet-metal screw

Insulation of manhole, horizontal connection

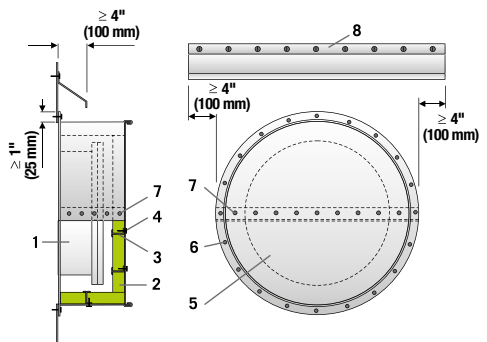

1. Manhole - 2. ProRox insulation - 3. Cladding (jacketing)
- 4. Sheet-metal screw (Self tappers or blind rivets) -
5. Cladding (jacketing) - 6. Sheet metal screw (self-tappers)

Various methods for pipe penetrations

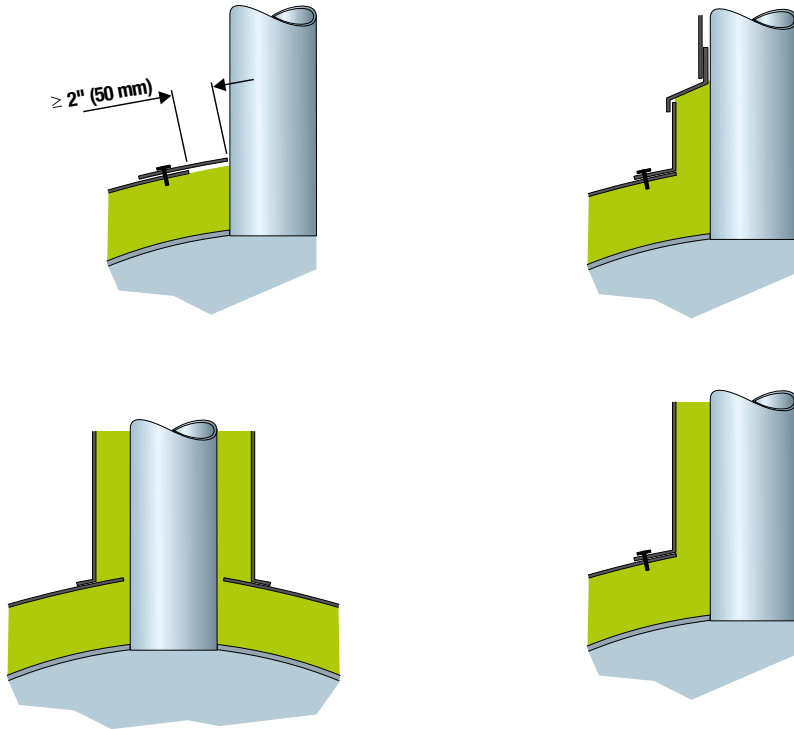

Support constructions and spacers

The application of support constructions and spacers on columns is essential. The objective of support constructions is to bear the weight of the insulation system and to bear the weight above mounting supports on the object to be insulated. The spacers keep the cladding (jacketing) of the insulation at a predetermined distance. On columns, which are always perpendicular, the substructures often assume the functions of the support construction and spacer.

The corresponding requirements for support constructions and spacers can be found in AGI guidelines Q153 and Q154.

Before commencing the insulation works, fit mounting supports to the column to which the support constructions are fitted. The shape, construction and measurements of mounting supports for support constructions must enable the insulation to be fitted during assembly. Use the design loads specified in DIN guidelines 1055-4 and 1055-5 to dimension the mounting supports and the support constructions and spacers.

1.4 Insulation of columns

Support constructions and spacers

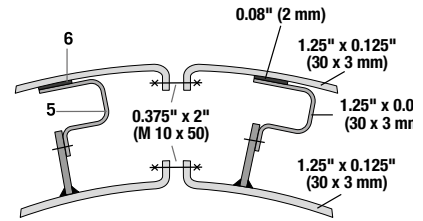
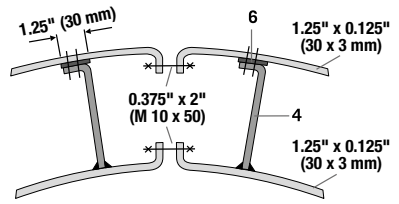
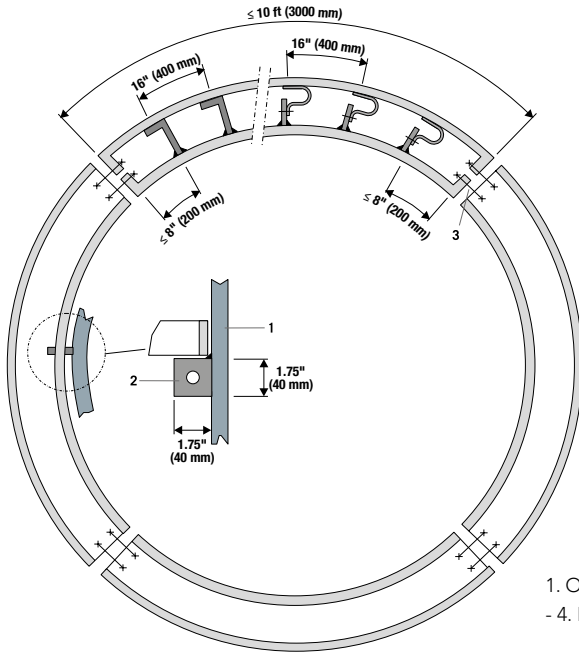

- 1. Object wall - 2. Mounting support - 3. Metric bolting
- 4. Bar - 5. Omega clamp - 6. Thermal separating layer

Cladding (jacketing)

The cladding (jacketing) of columns protects the insulation against mechanical influences and the weather. There is a wide range of different flat and profiled sheets available. See section 3.2.2 'Cladding (jacketing) materials' for an overview. Further details are also provided in Chapter 1.3 "Insulation of vessels".

Ladder support cleats

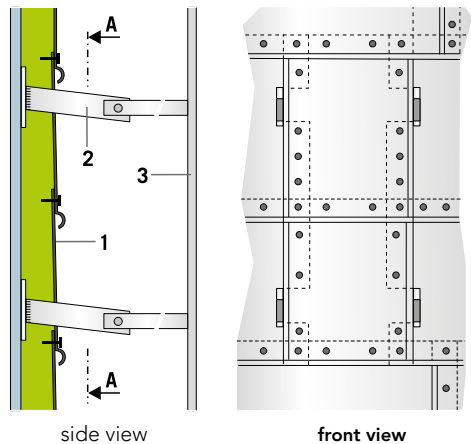

1. System solutions

1.5 Insulation of storage tanks

The availability of raw materials, fuels and the storage of end products is critical in almost all fields of industry. Generally, large tanks are used for raw materials, fuels and end products. Small tanks or vessels (see chapter 1.3) are used to temporarily store (semi) products. To conserve the substance and ensure the stability and safety of the production process, it is important to keep the temperature inside the tank between certain temperature limits.

Therefore the industrie sets high standards for the conditioning temperature of storage tanks. We give some examples:

- In the food industry, a milk cooling tank is a large storage tank used to cool and hold milk at a cold temperature until it can be packed and transported to the end-users.
- Storage facilities for liquefied gasses such as LNG, operate at very low temperatures up to -260°F (-168°C). Avoid evaporation or expansion of the liquefied gas, as this can result into safety problems.
- In the petrochemical industry, many storage facilities operate at high temperatures of 90°F to 430°F (30°C to 220°C) to avoid fluids, such as bitumen, spoiling or setting - which could result in problems with pumping or discharging from the tank.

Conclusion: Therefore, insulation of storage tanks is a major factor in the functionality of storage facilities. It also serves the following purposes:

- **Costs savings:** Insulation significantly reduces the heat and the so-called breathing losses of the substance. The pay-back time for the hot insulation is, even at lower temperatures [90°F (30°C)], usually less than 1 year, whereas the lifetime of the insulation may be many years.
- **Environment:** In addition to the cost savings achieved, reduced heat losses will also lead to lower CO₂ emission. Reduced breathing losses of hazardous substances prevents damage to our environment.

- **Process control:** Insulation will prevent tanks from freezing or being heated by solar radiation. It will also reduce the cooling of the stored substance, preventing it from setting and remaining in a solid form. In both cases additional heating or cooling may be applicable.
- **Safety:** A fire resistant insulation reduces the risk of a fire outside the tank igniting a flammable medium. It is also protection against contact by minimising the surface (contact) temperature of the tank.



Properly designed insulation work mainly depends on the isometrics and location of the storage tank, type of fluid and the purpose of the insulation. Even though the following examples of use are restricted to hot thermal insulation for outdoor application, the types of storage tanks used are so varied that the examples cannot fully take into account the particular circumstances of each case. Determine whether the products and construction described are suitable for the corresponding application in each individual case. If in doubt, consult the ROCKWOOL Technical Insulation sales team.

1.5 Insulation of storage tanks

The applicable standards and regulations must also be observed. A few examples follow:

- ASTM C1696 "Standard Guide for Industrial Insulation Systems"
- NACE SP0198 (Control of corrosion under thermal insulation and fireproofing materials - a system approach)
- MICA "National Commercial & Industrial Insulation Standards"
- DIN 4140 (Insulation works on industrial plants and building services installations)
- AGI Q05 (Construction of industrial plants)
- AGI Q101 (Insulation works on power plant components)
- CINI-Manual: "Insulation in industry"
- BS 5970 (Code of practice for the thermal insulation of pipework, ductwork, associated equipment and other industrial installations)
PIP (Process Industry Practices)

Insulation selection

Storage tanks are located outdoors, so it is important to select a material with a low thermal conductivity and excellent water repellent properties. ProRox semi-rigid slabs (board) such as ProRox SL 930, are mainly used to insulate tank walls. Applying a less water repellent, non pressure-resistant insulation like wired mats is not generally recommended. If foot traffic can occur, a pressure-resistant slab (board) such as ProRox SL 560 is applied for the insulation of the tank roof. If applying a product which is resistant to foot traffic is impossible, apply a support structure, where needed, to protect the insulation boards. For temperatures above 210°F (100°C) applying the insulation in at least 2 layers (so called masonry bond) is recommended.

Insulation of tank roofs

Insulating a tank is not easy. Corrosion of the tank roof can occur if the insulation is not properly installed and maintained. Therefore, many companies tend not to insulate the tank roof. A common assumption is that the still air above the hot fluid acts as insulation of the tank roof. This assumption is, however, not entirely correct. Due to the difference in temperature between the hot fluid and the non-insulated tank roof there is

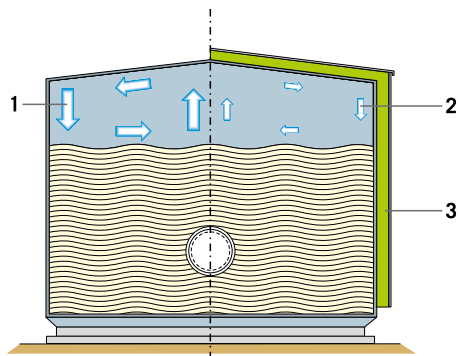

1. No insulation: strong convection -
2. Insulation: reduced convection -
3. ProRox insulation - semi-rigid slabs (board)

fairly strong convection, which results into considerable heat losses. Tank roof insulation is feasible if the proper insulation material and mounting and fixing methods are applied.

Construction

Before starting the insulation works, ensure that all preparatory work on the object has been completed. Refer to Chapter 1.1 for details. Outdoor storage tanks are continuously exposed to the environment. Wind causes both pressure and delamination, which can easily result in damage to the insulation protection – usually aluminum sheeting. Consequently, the aluminum sheeting is blown away and rain water can leak into the insulation. Water accumulation can cause corrosion resulting in severe corrosion of the tank, leakage of the substance inside etc. Correct precautions are necessary to ensure the quality and life-time of the insulation.

Many systems can cope with the demands. The appropriate system will greatly depend on the diameter, temperature tank, the surrounding environment and the possibilities to use scaffolding/rope access when mounting the insulation. In addition, the plant owner may have specific requirements. Determine whether the products and construction described are suitable for the corresponding application in each individual case. If in doubt, consult the ROCKWOOL Technical Insulation sales team.

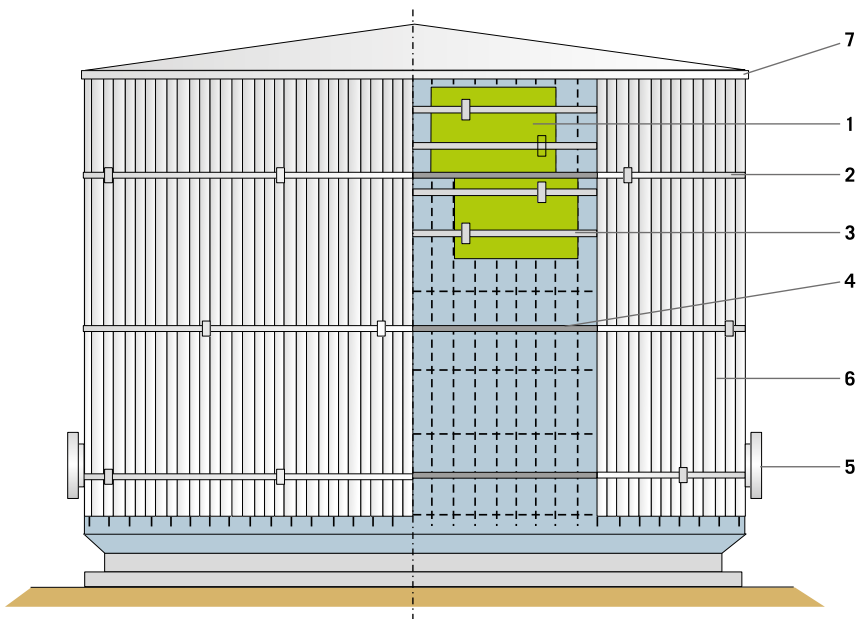

1. ProRox insulation - semi-rigid slabs (board) - 2. Stainless steel bands (weather proofing) - 3. Stainless steel bands - 4. Support ring - 5. Protrusion - 6. Cladding (jacketing) - 7. Roof/wall connection



Cladding (jacketing)

A metal cladding (jacketing) is generally applied for the tank wall and roof. Thanks to its light weight, low costs and ease of installation, aluminium is commonly applied as cladding (jacketing). In special circumstances (fire rating, corrosive environment etc) other materials such as stainless steel or glass fibre-reinforced polyester may be used.

1.5 Insulation of storage tanks

Support rings

With vertical applications, the weight of the insulation can damage the insulation layer below. To avoid damaging the insulation, fit horizontal support rings is higher than 14 ft (4 m). The distance between the support rings should not exceed 10 ft (3 m). The construction should be built so that leakage water can be expelled from the insulation.

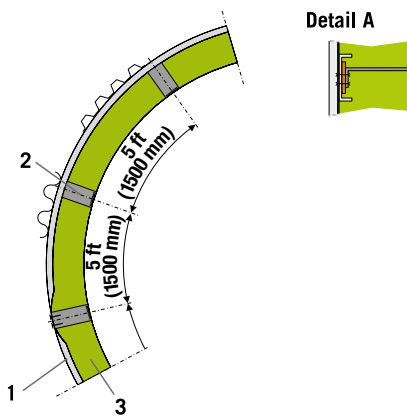

1. Tank wall - 2. Spacer - 3. ProRox insulation - semi-rigid slabs (board)

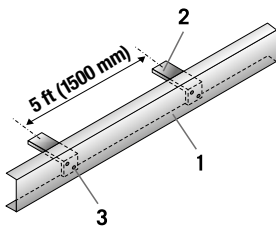

1. Horizontal support ring - 2. Spacer - 3. Fixing

Expansion

Large storage tanks expand due to changes in temperature and if the substance stored is filled or discharged (so called "bulging"). These factors can increase/decrease the tank diameter.

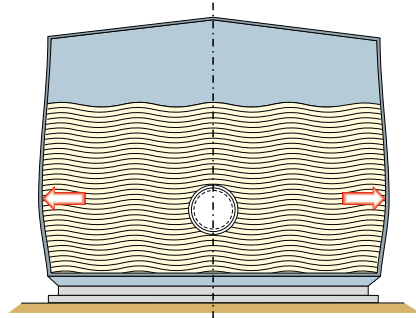

Example: The diameter of a storage tank - \varnothing 65 ft (20 m), Avg T 430°F (220°C) - will increase approx. 2 1/2" (60 mm). This consequently increases the tank circumference by approx. 7" (180 mm). To avoid stress/tension on the insulation protection (aluminium sheeting) selecting a flexible ProRox insulation slab (board) or wrap (mat) is important. For high temperatures, anticipate further expansion by fitting profiled sheeting.

Ladders and manholes

The necessary space requirements for the insulation must be taken into account when designing and planning the installation. The distance between the ladder and the tanks should be large enough to make installing insulation afterwards possible. Insulate manholes so they can still be used frequently without damaging the insulation.

Tank wall and tank base connection

When a tank is filled, stress may occur at the welded seam between the wall and base of the tank. For inspection purposes the first 1 1/2 ft (50 cm) of the tank wall should not be insulated. The first support ring is usually welded above this level and constructed so that leakage water can be expelled from the insulation.

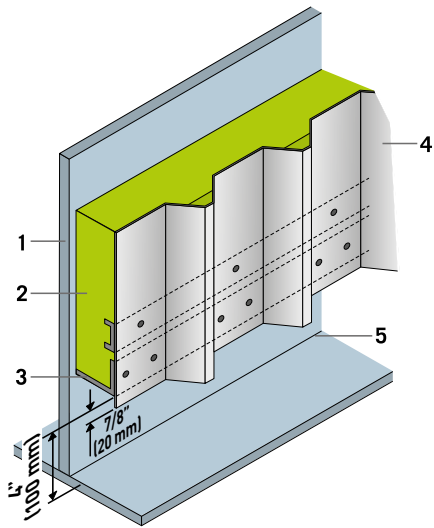

- 1. Tank wall - 2. ProRox insulation - semi-rigid slabs (board) - 3. Support ring - 4. Cladding (jacketing) - 5. Welded seam (keep free from insulation for inspection purposes)

Tank wall and tank roof connection

A rainwater shield is fitted at the seam between the tank wall and tank roof to prevent leakage into the tank wall insulation. Weld the safety guard / railing on this rainwater shield.

Connection tank wall - tank roof with railing

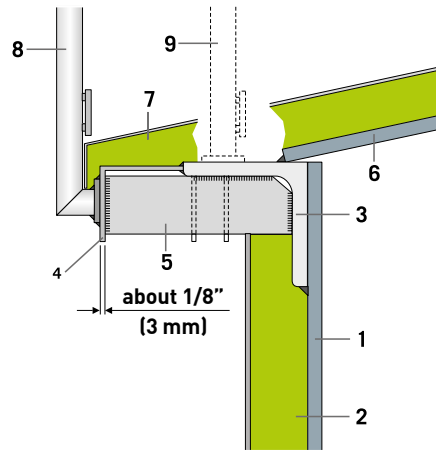

- 1. Tank wall - 2. ProRox insulation - semi-rigid slabs (board) - 3. L-profile - 4. Rain deflector (2 to 4 mm thick and min. 80 mm height)- 5. Support strip (at the level of the railing connection) - 6. Tank roof - 7. ProRox insulation - compression resistant slabs (board) - 8. Railing - 9. Depiction of a railing connection of a non-insulated roof

Connection tank wall - tank roof

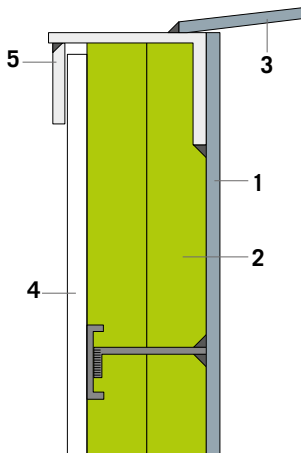

- 1. Tank wall - 2. ProRox insulation - semi-rigid slabs (board) - 3. Tank roof - 4. Cladding (jacketing) (aluminium) - 5. Deflector

1.5 Insulation of storage tanks

Protrusions within tank walls

Protrusions within the tank wall insulation may lead to leakage of rainwater or pollution with chemical substances. Keep the number of protrusions to a minimum. Insulate any remaining protrusions as indicated below. Optional, rain shield can be applied.

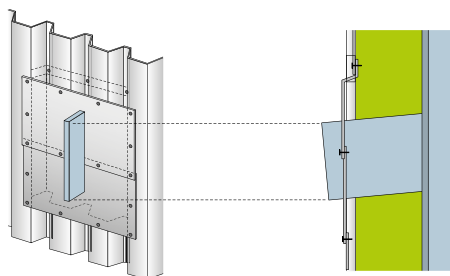
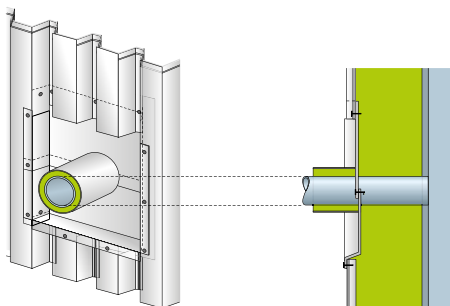

Finishing of tank roofs

Similar to tank wall insulation, many constructions are possible for tank roof insulation. The appropriate system greatly depends on the tank diameter and the nature of the seam with the tank wall. In addition, the plant owner may have specific requirements. The insulation is generally cladded with aluminium sheeting, "rivetted" or in radial segments. As tank roofs are vulnerable to delamination, screws may be damaged (pulled loose).

The suction caused by the wind on tankroofs can create delamination forces which unleash the fixings (screws ...) of the metal cladding (jacketing). This can be solved by applying the construction which can be seen in the illustrations shown on page 66: A, B and C. They show a welded steel bar (illustr. A) that is attached on the roof with a stainless steel strip on which the insulation is applied (illustr. B). As a last step (illustr. C) the insulation is finished by the cladding (jacketing).

If welding the roof is not possible, the steel radial segments in the centre of the roof can be hooked together in a ring around the perimeter of the roof. Turnbuckles are used to keep the radials correctly tensioned.

In many cases, the most critical aspect of tank insulation is preventing the leakage of rainwater inside the insulation. Water accumulation can cause corrosion resulting in severe corrosion of the tank. Correct precautions are necessary to ensure the quality and life-time of the insulation.

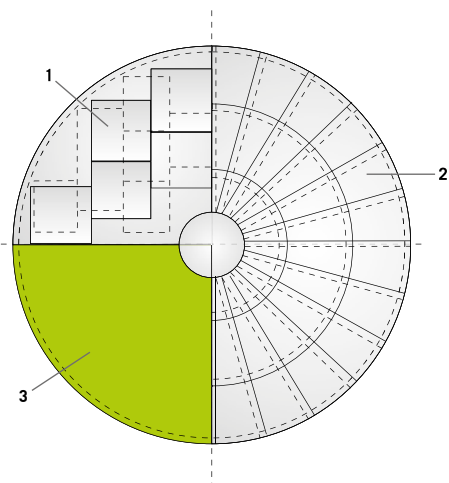

1. Finishing with aluminium cladding (jacketing) -
2. Finishing with steel radial segments -
3. ProRox insulation

A: welded steel bar attached on the roof with a stainless steel strip

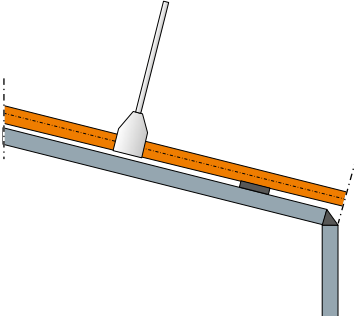

B: applying ProRox insulation

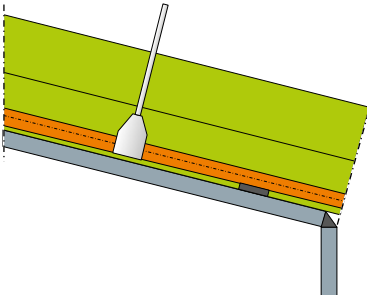

C: Finishing with aluminium cladding (jacketing)

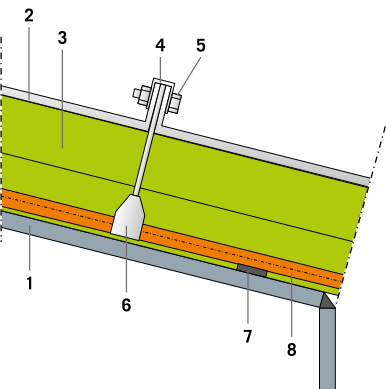

1. Tank roof - 2. Cladding (jacketing) - 3. ProRox insulation compression resistant slabs (board) - 4. Aluminium finishing strip - 5. Bolts and rivets (stainless steel) - 6. Strip (stainless steel) - 7. Weld - 8. Welded steel bar

Protrusions within tank roofs

Protrusions within the tank roof insulation may lead to leakage of rainwater or pollution with chemical substances due to overflowing of the tank. Keep the number of protrusions in the tank roof to a minimum. If this is not possible, apply the construction stated below.

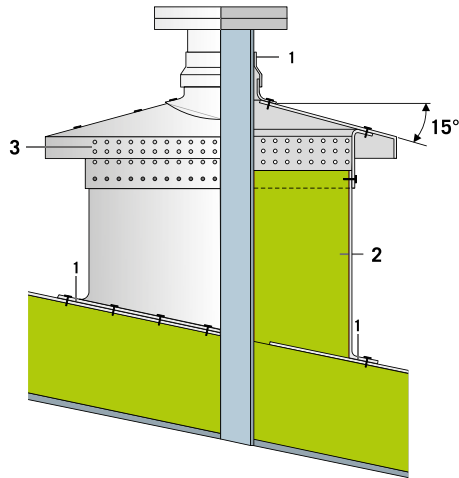
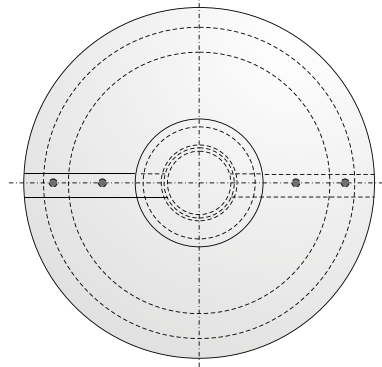

1. Sealing tape - 2. ProRox insulation - load bearing mat (wrap) - 3. Perforated sheet (ventilation)

1.5 Insulation of storage tanks

Foot traffic

Tank roofs are subject to foot traffic. To ensure the insulation system is resistant to foot traffic, apply a pressure-resistant slab (board) such as ProRox SL 560. If the radius of the tank roof is too large to allow the use of a rigid board, use a more flexible slab (board) such as ProRox SL 930 in combination with a (local) metal support construction. The walkways need to be clearly marked.



1. System solutions

1.6 Insulation of boilers

Hot water boilers and boilers for the production of water vapour under high pressures are considered to be steam boilers. As a generic term, boiler is used to denote steam generators and hot water installations. Insulating boilers has the following purposes:

- Reduces heat losses and increases the efficiency of the boiler
- Guarantees protection against contact by minimising the surface temperature
- Prevents heating of the compartment air in the boiler house, which guarantees an acceptable working environment

The design and functionality of the boilers on the market is so varied that the examples of use cannot fully take into account the particular circumstances of each case. Determine whether the products and construction described are suitable for the corresponding application in each individual case. In if doubt, consult the ROCKWOOL Technical Insulation sales team.

The applicable standards and regulations must also be observed. A few examples follow:

- ASTM C1696 "Standard Guide for Industrial Insulation Systems"
- NACE SP0198 (Control of corrosion under thermal insulation and fireproofing materials - a system approach)
- ASME "Boiler and Pressure Vessel Code"
- MICA "National Commercial & Industrial Insulation Standards"
- DIN 4140 (Insulation works on industrial plants and building services installations)
- AGI Q101 (Insulation works on power plant components)
- CINI-Manual: "Insulation in industry"
- BS 5970 (Code of practice for thermal insulation of pipe work, equipment and other industrial installations) PIP (Process Industry Practices)



1.6.1 Insulation of fire tube boilers

Fire tube boilers are often used in small and medium-sized industrial plants, where small and medium-sized mixtures of hot water or water vapour are required at low pressures. These boilers are used in the technical building appliances of large complexes, such as hotels, hospitals etc.

The fire tube boiler consists of a horizontally positioned cylindrical casing body with diameters of up to four metres. The interior generally contains a corrugated flame tube, where a fuel, which is usually oil or gas, is burnt. At the end of the boiler are so called reversing chambers, where the flue gas is reversed and pumped back through the boiler. Depending on the design, the boiler will have one or more gas flues, connected at the rear or the front base through the reversing chamber. The chamber surrounding the gas flues and the fire-tube is filled with the water to be heated.

1.6 Insulation of boilers

1.6.1 Insulation of fire tube boilers

Fire tube boiler

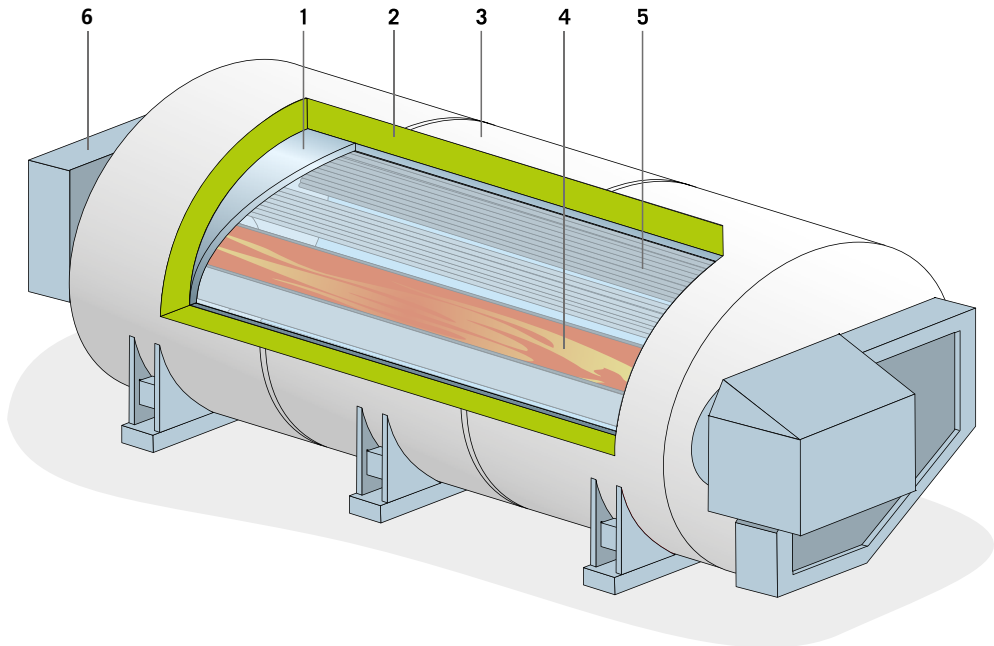

1. Boiler casing - 2. ProRox insulation - load bearing mat (wrap) or wired mat (mat) - 3. Cladding (jacketing) - 4. Flame tube - 5. Fire tube - 6. Reversing chamber

Applying load bearing mats (wraps) such as ProRox MA 520 ALU or ProRox MA 960^{NA} is a proven solution in the insulation of flame tube-smoke tube boilers. These mats (wraps) are easily mounted onto the horizontal, cylindrical boiler surface and are easily fastened to the boilers with metal straps. Metal spacers, which always create thermal bridges, can be omitted. Due to the compression resistance of at least 210 PSF (10 kPa), the cladding (jacketing) can be mounted directly onto the ProRox MA 520 ALU insulation. Alternatively, if the cladding (jacketing) is fitted so closely that it can adopt this function, the fastening straps can be omitted. The insulation is characterised by a consistent rigidity and surface. Due to the lack of spacers, it guarantees an even surface temperature without temperature peaks (so called hot spots), which pose a hazard in the form of skin burns.

The balanced surface temperature profile also accounts for the thermography of a flame fire tube boiler shown on this page. ProRox wired mats are generally used to insulate the area of reversing chambers and are secured with pins and spring clips.



1.6.2 Supercritical steam generators

In the modern energy and heat economy, supercritical steam generators, which burn fossil fuels such as mineral coal, brown coal and anthracite etc. are used to generate steam to operate steam turbines. In current utility steam boilers, up to 3,600 t steam is generated per hour under pressures of 4350 PSI (300 bar) and steam temperatures of 1150°F (620°C). The most common type is the Benson boiler, that is operated by forced circulation (with boiler feed pumps). In contrast to fire tube boilers, the water or vapour is not located in the vessel, but in pipes, which are fitted in gas-tight, welded tube-fin constructions and form the walls of the boiler. Generally constructed as single-pass or two-pass boilers, these boilers reach levels of up to 560 ft (160 m), depending on the fuel used. The bottom contains the furnace, where finely ground fuel is burned. The flue gases flow through the boiler and heat the water in the pipes, thereby causing it to evaporate. The boiler casing is suspended on a frame and can compensate for any thermal expansions that occur during operation (vertical and horizontal expansions). These types of expansions must be considered during the design of the insulation system. The diagram on the right shows the most important technical components in the insulation of a boiler.

Buckstays (Girders)

Buckstays (sometimes referred to as Girders, Stiffeners or Ribs) are fitted horizontally at regular intervals around the boiler. Buckstays are reinforcement elements, which prevent the boiler from bulging. A distinction is made between hot buckstays, which are located inside the insulation, and cold buckstays, which are located outside the insulation sections.

Dead spaces

Dead spaces are located in front of the boiler wall or boiler roof, where installation components such as collectors, distributors or pipes are fitted. The dead spaces are located inside the insulation.

Handles

Handles are reinforcement elements, which are fitted vertically between the buckstays and bear the vertical loads exerted on the buckstays on the boiler wall. Handles can be located inside and outside the insulation sections.

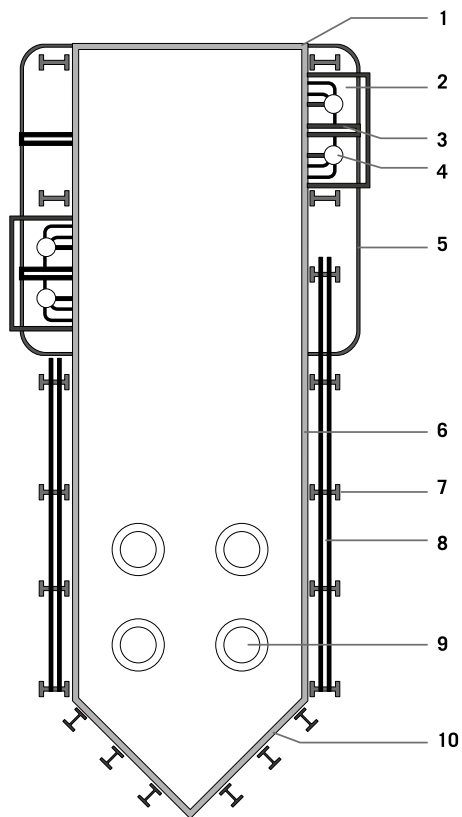

1. Boiler roof - 2. Dead space - 3. Cross bar - 4. Collector - 5. Boiler support tube - 6. Boiler wall - 7. Buckstay - 8. Handles - 9. Burner port - 10. Boiler funnel

1.6 Insulation of boilers

1.6.2 Supercritical steam generators Installation of the insulation system for utility steam generators

The following product characteristics are important when selecting a suitable insulation system for utility steam generators:

- The insulations used must be non combustible.
- The maximum service temperature of the insulation must be higher than the operating temperature of the installation component to be insulated.
- The thermal conductivity must be specified as a function of the temperature.
- The (longitudinal) air flow resistance must be as high as possible. High flow resistances reduce convection in the insulation.

In addition to protection against contact and the maximum permissible surface temperatures of 140°F (60°C), industrial parameters such as efficiency factors must be considered during the design of the insulation thickness. The AGI guideline Q101, "Insulation works on power plant components" recommends that the insulation layer thicknesses for power plant components is designed for a maximum heat flow rate density of 47.5 BTU/hr.ft² (150 W/m²). In view of rising energy prices and the socio political target of CO₂-emission reductions, this generally recommended value is, however, subject to critical analysis. From an economic and environmental perspective, a design parameter of well below 47.5 BTU/hr.ft² (150 W/m²) is often sensible. ProRox insulations have proven invaluable in the insulation of utility steam generators over decades. They are flexible and can be easily mounted onto the various geometries or surface structures. ProRox wired mats are non combustible, have high maximum service temperatures and exhibit a low degree of thermal conductivity across the entire temperature range.

The insulation is assembled in multiple layers, comprising two to three layers of insulation. The ProRox insulations with a maximum service temperature of 1200°F (650°C) are a tried and tested solution as a first insulating layer in upper temperature ranges, as are often encountered in dead spaces. Outer layers can be constructed

with different types of ProRox insulation to optimize the overall performance, depending on the temperature of the adjacent layer. In accordance with AGI guideline Q101 when using wired mats, galvanised wire netting and galvanised stitching wire can only be heated up to a temperature of 750°F (400°C). With temperatures above 750°F (400°C), austenitic stainless steel wire netting and stitching wire must be used. To reduce the convection in the insulation of vertical constructions such as boilers, only use insulations that exhibit an air flow resistance of ≥ 50 kPa s/m².

Diagram of a boiler insulation system with wired mats

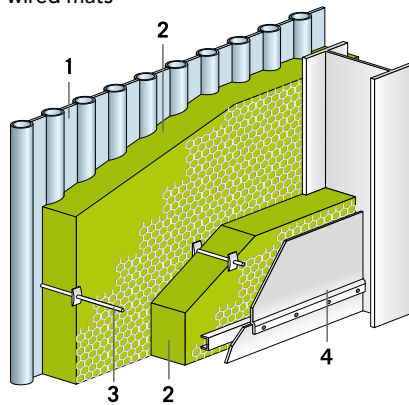

1. Tubed wall - 2. Insulation: ProRox wired mats - 3. Fastening pins with spring plates - 4. Cladding (jacketing)

Before starting the insulation works, ensure that all preparatory work on the object has been completed. Refer to Chapter 1.1 for details.

The wired mats are fastened to flat surfaces with at least six pins per m², and on the underside with at least ten pins per m². High temperature boards are fastened to flat surfaces with at least 5 pin per board, and on the underside with at least 8 pins per board. The pins are either welded directly onto the surface of the object or are screwed into nuts. With finned walls (tube-fin walls), the pins cannot be fixed to the pipes, but must be welded

onto the bars between the pipes. Observe the following when pinning the insulation:

- With insulation thicknesses $\leq 5"$ (120 mm), use 8GA (6AWG) pins with a minimum diameter of 0.162" (4 mm).
- With insulation thicknesses ranging from 5 1/2" to 10" (130 to 240 mm), use 6GA (4AWG) pins with a minimum diameter of 1/4" (6 mm).
- With insulation thicknesses $\geq 10"$ (240 mm) use 4GA (3AWG) pins with a minimum diameter of 1/4" (6 mm).
- Without a gap between the two, the pins must be 3/8" (10 mm) shorter than the insulation thickness.
- Fasten each insulation layer with clips.

With wired mats, all the lengthwise and crosswise joints must be sewn or wired together, or joined with six mat (wrap) hooks per metre. If the insulation is assembled in multiple layers, the joints of the individual insulation layers must be staggered.

The following illustrations show a number of typical methods of insulating boilers.

Diagram of a boiler insulation system with a gap between the insulation and cladding (jacketing)

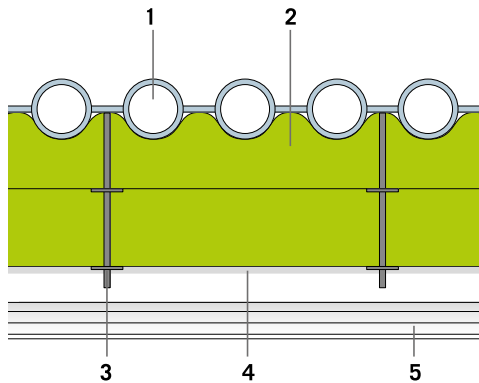

1. Finned pipe - 2. ProRox insulation -
3. Fastening pins with spring plates - 4. Aluminium foil if necessary - 5. Cladding (jacketing) (e.g. profiled sheet)

Diagram of a boiler insulation system with no gap between the insulation and cladding (jacketing)

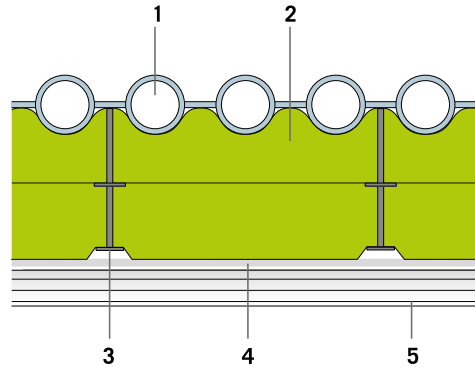

1. Tube wall - 2. ProRox insulation - 3. Spring plates -
4. Aluminium foil if required - 5. Cladding (jacketing) (e.g. profiled sheet)

Convection in the insulation

With vertical insulation constructions in particular, where cavities can form on the heated side between the object and the insulation, there is an increased risk of heat losses – caused by convection in the insulation. This risk equally applies to finned walls, as an insulation that follows the contours of the object, in which the cavities in the area of the bars are sealed, cannot always be secured. Take the following measures to prevent convection:

- Construct vertical barriers at intervals of 16 to 26 feet (5 to 8 m).
- Only use insulations with a longitudinal flow resistance of ≥ 50 kPa s/m².
- Fitting an aluminium foil between the individual insulation layers and/or on the exterior is recommended.

1.6 Insulation of boilers

1.6.2 Supercritical steam generators

Barriers

The following diagrams show two designs for vertical barriers. Depending on the temperature or structural requirements, the barrier can be manufactured from sheet metal [$\geq 0.02"$ (0.5 mm)] or aluminium foil [$\geq 0.003"$ (80 μm)]. The barrier must be fastened to the object on the heated side and must reach to the cladding (jacketing) on the cold side. Fill interstices with ProRox LF 970. Where the insulation is constructed in multiple layers, cascade the barriers.

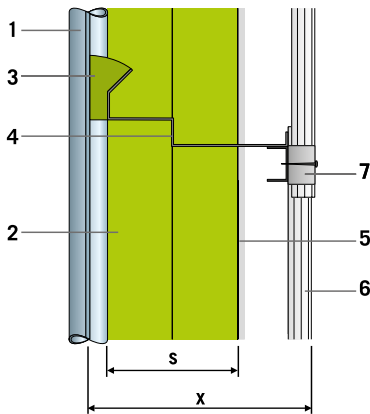

1. Boiler wall - 2. ProRox insulation - 3. Fill with ProRox loose fill - 4. Convection barrier sheet - 5. Aluminium foil if required - 6. Cladding (jacketing) - 7. Mineral wool profile filling - s. required insulation-layer thickness - x. design dimension

Insulation of the buckstays

Buckstays (girders) that are exposed to heat are insulated and fitted with a casing. An example follows.

Buckstays exposed to heat on a boiler wall

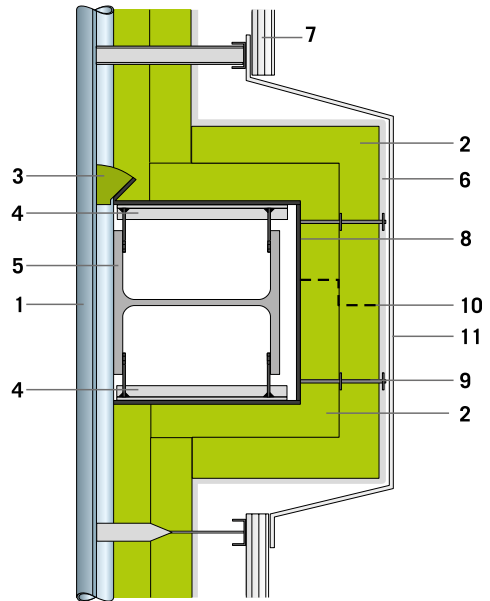

1. Boiler wall - 2. ProRox insulation - 3. Fill with ProRox loose fill - 4. Support construction - 5. Buckstay exposed to heat - 6. Aluminium foil if required - 7. Cladding (jacketing)/Preformed sheet - 8. Internal buckstay cover, made from black sheet - 9. Mat (wrap) pins with clips - 10. Aluminium foil barrier - 11. Flat cladding (jacketing)

Buckstays that are exposed to cold are generally not insulated and not cladded. An example follows.

Buckstays exposed to cold on a boiler wall

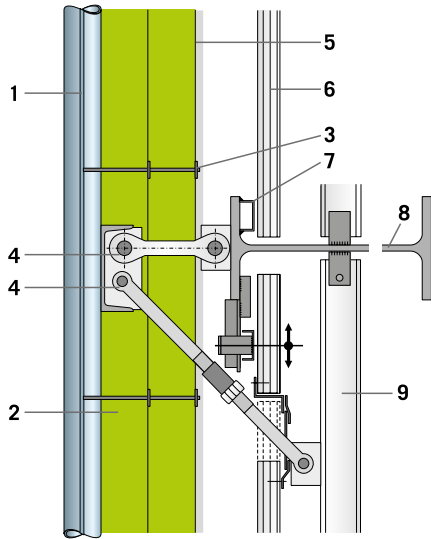

1. Boiler wall - ProRox insulation - 3. Mat (wrap) pins with clips - 4. Buckstay deflectors - 5. Aluminium foil if required - 6. Cladding (jacketing)/profiled sheet - 7. Substructure - 8. Cold buckstay - 9. Boiler handle

Insulation of dead spaces

Dead spaces located in front of the boiler wall or roof containing installation components, are enclosed with cladding (jacketing), to which the insulation is then mounted. Use a non-scaling sheet with a minimum thickness of one mm. Fasten the sheets to appropriate, structurally measured substructures so that the thermal expansions can be accommodated. The insulation is secured to the dead space sheeting with pins as described above.

An example of dead space insulation follows.

Dead space for boiler wall collector

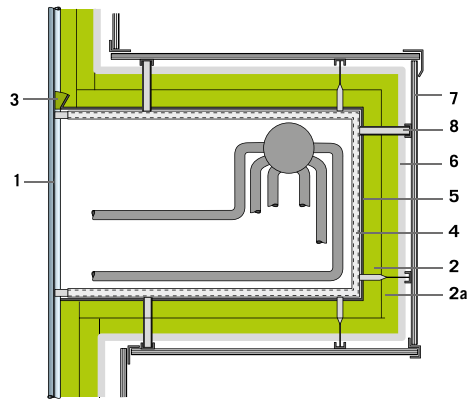

1. Boiler wall - 2. ProRox insulation - 3. Fill with ProRox loose fill - 4. Support construction - 5. Dead space sheeting - 6. Aluminium foil if required - 7. Cladding (jacketing)/Preformed sheets - 8. Support construction and spacer

1.6 Insulation of boilers

1.6.2 Supercritical steam generators

Support construction and spacer

There are various options available to attach support constructions and spacers to boilers. They can be mounted directly onto the boiler, to auxiliary constructions, to buckstays (girders), cross bars or handles. When selecting the support construction and spacer and the corresponding attachment option, a design matching must take place between the insulator and the plant manufacturer. With power plant components with temperatures above 660°F (350°C), use high temperature or fireproof steel.

Cladding (jacketing)

With power plant components with large surface areas, such as utility steam generators, profiled sheets are used as cladding (jacketing) material for structural, economic and design reasons. The open spans, overlaps and connections correspond to the profile. Refer to the instructions of the relevant profiled sheet manufacturer.

When selecting a suitable cladding (jacketing) material, consider the following parameters: corrosion, temperature resistance, type of construction and architectural design. The contractor and customer should consult about this matter.

Galvanised steel sheeting is generally used for the insulation of utility steam generators, which are usually located inside buildings.

1. System solutions

1.7 Insulation of flue gas ducts

Burning fossil fuels produces flue gases, which are guided through flue gas ducts through the various cleaning stages, such as denitrification (DENOX) desulfurization (DESOX) and dust removal (EN), discharged into the atmosphere. Large sections of flue gas ducts are often located outdoors. They are subject to an extent to both internal and external extreme conditions.

The effects of external atmospheric influences, such as wind and rain, as well as varying ambient temperatures on the flue gas duct, can lead to intense cooling of the flue gases internally, and therefore to the accumulation of sulphuric acids, which facilitate corrosion.

Insulation systems on flue gas ducts have the following purposes:

- Reduce heat losses in the flue gas, thereby preventing sub-dew point (acid or water dew point) conditions in the flue gas on the interior surfaces of the flue gas duct. This also minimises the corrosion risk. This also applies to areas with structural thermal bridges, such as support constructions, reinforcements etc.
- Reduce the heat losses in flue gas channels of heat recovery systems
- Personal protection
- Adherence to technical specifications with regard to noise

Designs are so varied in terms of their size and geometry, as well as the materials and layers used, that the examples of use below cannot fully take into account the particular circumstances of the construction-related factors.

Determine whether the products and construction described are suitable for the corresponding application in each individual case. If in doubt, consult the ROCKWOOL Technical Insulation sales team.

Furthermore, the applicable standards and regulations must be observed.

A few examples follow:

- ASTM C1696 "Standard Guide for Industrial Insulation Systems"
- ASME "Boiler and Pressure Vessel Code"
- MICA "National Commercial & Industrial Insulation Standards"
- DIN 4140 (Insulation works on industrial plants and building services installations)
- AGI Q101 (Insulation works on power plant components)
- CINI manual: Industrial insulation
- BS 5970 (Code of practice for thermal insulation of pipe work, equipment and other industrial installations) PIP (Process Industry Practices)

1.7.1 Installation of the insulation systems for flue gas ducts

ProRox wired mats and slabs (board) have been a proven solution for rectangular flue gas ducts for many decades. They are flexible and can fit onto different geometries and surface structures. ProRox insulation products are non-combustible, have high maximum service temperatures and exhibit a low thermal conductivity across the total temperature range.

Secure the insulation to the **rectangular ducts** with welding pins and spring clips. Before the welding pins are fitted, a bonding procedure should be determined by the plant manufacturer and insulator, which does not damage any corrosion coating present on the inside and outside of the flue gas duct. For example, it may be advisable to fit the welding pins before constructing the corrosion coating.

ProRox insulation should must be secured to flat surfaces with at least six pins per m² for wired mats [for insulation with slabs (board) at least five pins per slab (board)], and on the undersides with at least ten pins per m² for wired mats [for insulation with slabs (board) at least eight pins].

1.7 Insulation of flue gas ducts

1.7.1 Installation of the insulation systems for flue gas ducts

Observe the following when pinning the insulation:

- With insulation thicknesses ≤ 5 " (120 mm), use 8GA (6AWG) pins with a minimum diameter of 0.162" (4 mm).
- With insulation thicknesses ranging from 5 1/2" to 10" (130 to 240 mm), use 6GA (4AWG) pins with a minimum diameter of 0.2043" (5 mm).
- With insulation thicknesses ≥ 10 " (240 mm) use 4GA (3AWG) pins with a minimum diameter of 1/4" (6 mm).
- If the cladding (jacketing) rests directly on the insulation without a gap between the two, the pins must be 3/8" (10 mm) shorter than the insulation thickness.
- Fasten each insulation layer with clips.

With wired mats, all the lengthwise and crosswise joints must be sewn or wired together, or joined with six mat (wrap) hooks per metre. If the insulation is assembled in multiple layers, the joints of the individual insulation layers must be staggered.

To reduce convection in the insulation, fitting barriers is recommended, for example made from steel, at intervals of 16 to 26 feet (5 to 8 m) when working on large vertical surfaces. The barrier must be effective across the entire section of insulation up to the cladding (jacketing).

ProRox insulation is recommended for **round flue gas ducts**, where temperatures are below 550°F (300°C). This is mounted directly onto the flue gas duct and is fastened with straps. A fastening with welding pins and spring clips is generally not required in this instance.

Insulation of reinforcement elements

Large flue gas ducts are fitted with reinforcement profiles to stabilise the duct. These can consist of double T-girders, hollow sections or reinforcing ribs and form potential thermal bridges. This may cause the following problems:

- The thermal bridges cause an increased heat flow and lead to a temperature decrease on the inside wall of the ducts.
- Temperature variations between the inner and exterior lead to stress in the profiles. If the tensile forces become too great, this can lead to deformations and breaking of the welding.

Preventing temperature drops on the inside wall

To prevent a drop in temperature on the inside wall in the area of reinforcement profiles, they must always be insulated. The insulation thickness required depends on factors such as the size and geometry of the profiles, the temperature level and rate of flow within the flue gas duct and the operating method. Complex calculations may be required to determine the insulation thickness. These are usually established by the plant manufacturer, who is aware of the installation parameters. When starting up the installation, a brief drop in temperature below the dew point of the flue gas is unavoidable on the inside wall of the duct.

Reduction of stress due to temperature in the reinforcement profiles

The operating method of the installation influences the problem of stress in the reinforcement profiles caused by temperature.

Less critical is the **steady operation**, where the flue gas temperature does not change with the passage of time. Generally, stresses due to temperature are not critical if the implementation principles outlined in the AGI guideline Q101 are observed:

- The insulation thickness across the reinforcement elements should be of the same thickness as the insulation on the flue gas duct.
- In the case of ducts with reinforcing ribs up to a height of 4" (100 mm), the thickness of the insulation layer across the ribs must measure at least one third of the insulation thickness required for the duct.

Insulation of reinforcing ribs

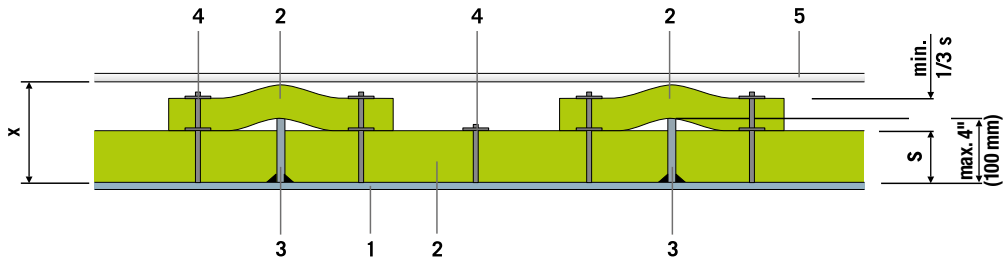

1. Duct wall - 2. ProRox insulation - 3. Reinforcing ribs - 4. Welding pins with clips - 5. Cladding (jacketing)

In the case of non-steady operation, for example, when starting up the installation causes fluctuating flue gas temperatures, measures must be taken if necessary to allow even heating of the reinforcement profiles. The temperatures on the duct wall, as well as on the inside of the reinforcement element, increase rapidly when the installation is started up, whilst the outside of the profile remains cold at first and only heats up after a longer delay. This leads to temperature differences, which can cause undue stressing of the component. The extent of the temperature differences depends on numerous parameters. A few examples follow:

- The operating speed influences the speed at which temperature of the flue gas increases and the temperature difference in the reinforcement element.
- High temperature differences occur in the case of large profiles.
- The shape of the reinforcement profiles influences an even temperature distribution. Thick walled profiles, for example, do not warm up as evenly as thin walls.
- The different thermal conductivities of the materials used and the heat transfer rates lead to an uneven temperature distribution.

To reduce the temperature differences, the insulation must be structurally designed to enable as much heat as possible to be transported by

means of radiation and convection from the duct wall to the external flange of the reinforcement profiles. The following shows the design details for a profile insulation system.

Insulation of reinforcing ribs

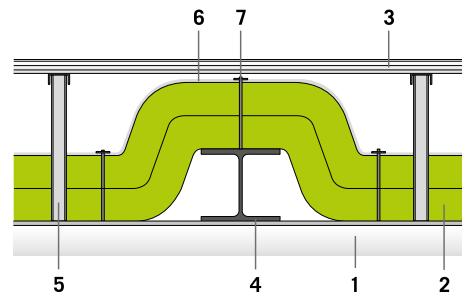

1. Duct wall - 2. ProRox insulation - 3. Cladding (jacketing): corrugated sheet - 4. Reinforcing element - 5. Supporting construction and spacer - 6. Aluminium foil (optional) - 7. Welding pins/clips

This type of design is generally recommended for profiles measuring up to $\leq 10''$ (240 mm) in height.

1.7 Insulation of flue gas ducts

1.7.1 Installation of the insulation systems for flue gas ducts

Insulation of reinforcing element with cavity and covering sheet

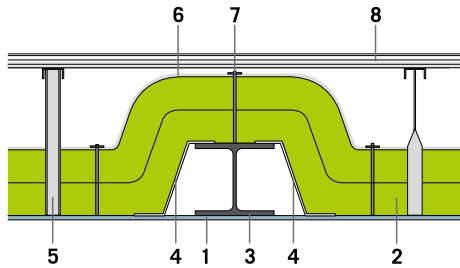

1. Duct wall - 2. ProRox insulation - 3. Reinforcing element - 4. Covering sheet - 5. Support construction and spacer - 6. Aluminium foil (optional) - 7. Welding pins/clips - 8. Cladding (jacketing): corrugated sheet

In the case of profiles measuring above 10" (240 mm) in height, a covering sheet should also be installed. The heat transfer from the duct wall to the external flange is therefore not impeded and the cavities do not need to be insulated.

The profile insulation described leads to increased heat losses through convection in the case of vertical steel girders. As a result, barriers – for example in the form of sheets welded into the reinforcement elements – must be fitted at intervals of approximately 10 to 16 feet (3 to 5 m) to reduce convection.

1.7.2 Cladding (jacketing) of flue gas ducts

Due to their size and the associated high demands placed upon the flexural rigidity of cladding (jacketing), flue gas ducts are encased with profiled sheets such as trapezoidal sheets. Flat sheets, which are generally cambered, can also be used. The cladding (jacketing)s are secured to the flue gas duct using substructures.

With ducts located outdoors with flue gas temperatures of < 250°F (120°C), an air space of at least 9/16" (15 mm) should be left between the cladding (jacketing) and insulation. On clear nights, especially, there is a risk that thermal radiation in space (the small surface of the "flue gas duct" radiates on an endlessly large surface "space"), will cause the surface temperature of the cladding (jacketing) to fall below the dew point temperature of the ambient air. The atmospheric humidity from the ambient air can then condense on the inside of the cladding (jacketing). Therefore, the insulation and cladding (jacketing) must not be allowed to touch. To drain the water, drill drainage or ventilation holes at the lowest point on the underside.

With round flue gas ducts constructed using ProRox insulation without a spacer then corrugated straps or bubble wrap are inserted between the insulation and cladding (jacketing) as a spacer.

If the duct is located outside, the upper surface of the cladding (jacketing) should have a gap of $\geq 3\%$. The following pages show two examples for the cladding (jacketing) of a flue gas duct with a pent or gabled roof.

Duct located outdoors with a cladding (jacketing) constructed as a pent roof

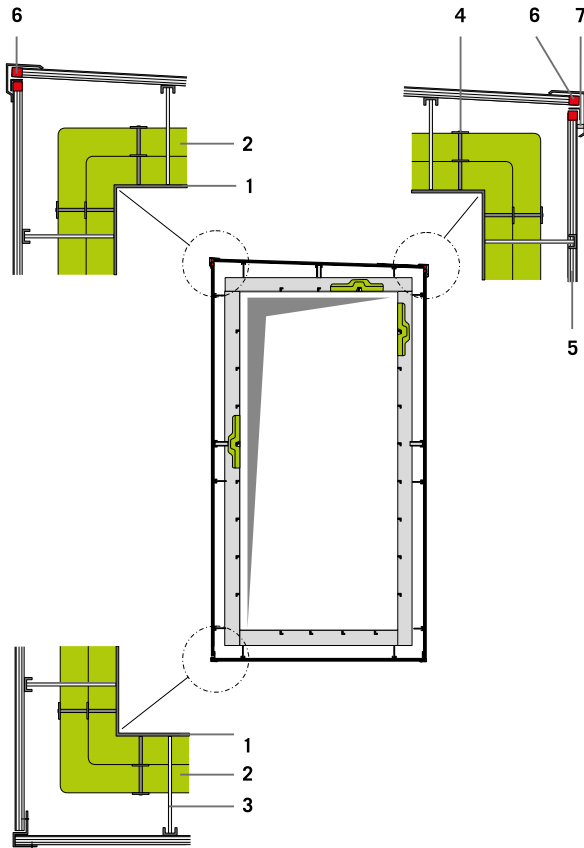

- 1. Duct wall - 2. ProRox insulation - 3. Support construction and spacer - 4. Welding pins/clips -
- 5. Cladding (jacketing): corrugated sheet - 6. Extension (trapezoid) - 7. Z-shaped spacer

1.7 Insulation of flue gas ducts

1.7.2 Cladding (jacketing) of flue gas ducts

Duct located outdoors with a cladding (jacketing) constructed as a saddle roof

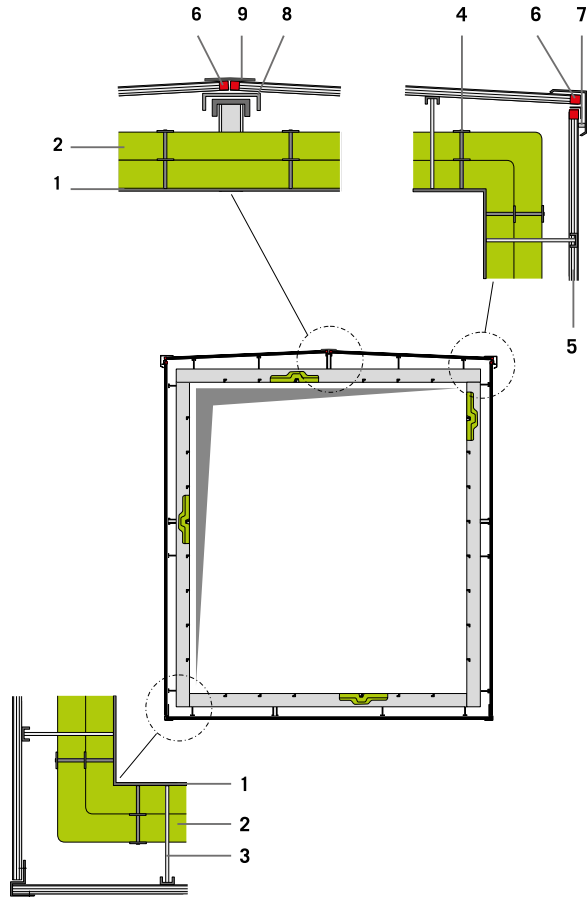

- 1. Duct wall - 2. ProRox insulation - 3. Support construction and spacer -
- 4. Welding pins/clips - 5. Cladding (jacketing): corrugated sheet - 6. Extension (trapezoid) -
- 7. Z-shaped spacer - 8. Support construction - 9. Ridge

1.7.3 Acoustic insulation of flue gas ducts

The thermal insulation of flue gas ducts influences the propagation of airborne noise and structure-borne noise. The effects of this depend on many factors, such as the frequency, the noise pressure level and the structure. The following structural measures influence the acoustic properties of an insulation system:

- Changing the insulation layer thickness and/or the apparent density of the insulation
- Changing the clear distance between the flue gas duct and the cladding (jacketing)
- Acoustic decoupling of the cladding (jacketing) from the flue gas duct using elastic elements within the support construction and spacer (e.g. omega clamp, rubber elements, steel wool pads)
- Increasing the basic weight of the cladding (jacketing) through the choice of material or sheet thickness
- Internal coating of the cladding (jacketing) with sound-deadening materials
- Construction of the insulation in multiple layers, with at least two separate insulating layers and cladding (jacketing)

1. System solutions

1.8 Cold boxes

Many industrial applications use gases such as oxygen, nitrogen and argon. These gases are obtained using cryogenic gas separation technology, whereby air is condensed and converted into a liquid. Afterwards, the various elements can be separated using fractional distillation.

So-called air separation plants are characterised by an extremely low temperature of as low as approximately -328°F (-200°C). In addition to the risk of water and ice forming at this cryogenic temperature, there is also the risk of pure oxygen condensing against the cold parts of the system. The presence of oil and grease may be enough to cause the high concentration of oxygen to spontaneously combust.

This is obviously an extremely hazardous situation. The presence of oil and grease must therefore be avoided at all times. It is vitally important to well insulate all cold parts of the system, such as vessels and pipes. Strict specifications regarding the insulation are therefore essential. A frequently applied standard for the insulation of air separation plants is the AGI Q118 standard "insulation work on air separation plants". This standard describes in detail the various parts of the installation and the insulation to be applied. The construction method naturally depends on the application. The following instructions are limited to the insulation of so-called cold boxes.

Cold boxes

An important component in gas separation plants are the so-called "cold boxes". Cold boxes are (pressure) vessels that hold a gas or liquid at a very low temperature. The distinctive feature of cold boxes is the double-wall construction, which allows the insulation to be fitted between the inner and outer walls. The cold box is sealed after the insulation has been fitted, so the insulation can no longer come into contact with, for example, water, snow, dust and contaminants.



Choice of insulation

The choice of insulation material depends on a variety of parameters, including the user requirement, standards (e.g. AGI Q118), the operating temperature and the accessibility of the installation. In many cases, mineral wool fibres are used (e.g. ProRox GR 903), which contain a very low proportion of organic substances- the so-called "Linde Quality". This can be easily injected into the vessel and has a very long lifespan. The material is easily removed for inspection purposes.

Fitting the insulation

In compliance with the AGI Q118 standard, the fibres are fitted manually or using an injection technique. The hollow spaces in the installation must be free of water and other liquids and contaminants. All filling openings (and non-filling openings) must be sealed. An optimum result is achieved by pulling the packaged, loose fibres apart before injecting or shaking them into the vessel. The ProRox GR 903 must be injected or shaken into the unit in even layers.

If necessary, the wool can then be tamped to achieve the required density. To avoid damage to the installation, manually filling certain parts of the installation may be advisable. The ultimate density

of the fitted wool depends on how it is fitted. Densities of at least 9.4 lb/ft³ (150 kg /m³) are feasible. The official requirement according to the AGI Q118 standard is 10 to 12.5 lb/ft³ (160 to 200 kg/m³). The procedure is outlined step by step as follows:

1. Create a trial set up by filling a 2 x 2 x 2 ft (60 x 60 x 60 cm) crate with an evenly distributed layer of loose wool, with a thickness of 12 to 16" (300 to 400 mm). Then have a man of average weight compact this layer by treading on it. Repeat this process until the box is full. Calculating the quantity of wool used by mass afterwards allows the feasible density to be determined. This also gives a good idea of the tamping method required in order to achieve an effective filling density.
2. Before starting to fill the cold box, fill the installation with air to create a slight over-pressure. This will make any possible leaks, which can occur during the tamping process, audible.
3. The cold box is filled with an evenly distributed layer of ProRox GR 903 granulate, with a thickness of 12 to 16" (300 to 400 mm). Tamp down this layer until a density is reached that corresponds to the density in step 1.
4. Repeat step 3 until the cold box is completely filled. Check the filling density by regularly calculating the number of kilograms used in relation to the filled volume. The pressure required to achieve a certain density depends on the procedure that has been followed.

Note

As ProRox GR 903 granulate may settle after a while or the shape of the cold box may alter due to temperature fluctuations, take into account that the unit will need to be refilled.



2

Theory

ProRox®

Industrial
insulation

Theory

2. Theory

Table of contents

2.1	Norms & Standards	96
2.1.1	Overview of different norms & standards	96
2.1.2	Insulation specifications	97
	a) CINI Guideline	97
	b) PIP - guidelines	98
	c) ASTM standards	99
	d) European standardisation (CEN)	100
	e) CE-mark	101
	f) DIN standards & guidelines	101
	g) AGI guidelines	102
	h) BFA WKSB guidelines	103
	i) FESI guidelines	103
	j) ISO standards	104
	k) VDI 2055 guideline	104
	l) British Standard (BS)	105
	m) Norme Française (NF)	106
	n) Document Technique Unifié (DTU)	108
	o) API Standards	108
	p) Canadian Standards	109
	q) MICA Standards	109
	r) NACE International Standard Practice	109
2.1.3	Relevant guidelines & standards for the industrial insulation industry in North America	110
2.1.4	Relevant guidelines & standards for the industrial insulation industry in Europe	110
2.1.5	Relevant guidelines & standards for the industrial insulation industry in Germany	110
2.1.6	Relevant guidelines & standards for the industrial insulation industry in Benelux	117
2.2	Product properties & test methods	118
2.2.1	Fire behaviour	118
2.2.2	Thermal conductivity	120
2.2.3	Maximum service temperature	122
2.2.4	Water leachable chloride content	125
2.2.5	Water repellency	126
2.2.6	Water vapour transmission	128
2.2.7	Air flow resistance	128
2.2.8	Compression resistance	128
2.2.9	Density	129
2.2.10	Acoustic performance	130
2.3	Bases for thermal calculations	131
2.3.1	Heat transfer	132
	a) Heat transfer – European basis and terms	132
	b) Heat transfer – ASTM C168 and C680 - North American basis and terms	135

2. Theory

2.1 Norms & Standards

2.1.1 Overview of different norms & standards

There are numerous standards, guidelines and specifications for the planning, design and construction of technical insulation systems. These regulations must be observed to guarantee the functionality, economic operation and safety of a technical installation, as well as a long service life.

Industrial plants are built and maintained according to a range of requirements, detailed in numerous technical standards that cover all design and equipment requirements.

An overview of the commonly used standards, guidelines and specifications is mentioned below.

Society standards

Published standards from an accredited standards developer. Common examples are ASTM, European Standard (EN), DIN. Often related to product performance.

Industrial guidelines for insulation

In many cases, industrial guidelines are established to ease and to reduce the development & maintenance time and effort of specifications sharing best practices. They contain detailed technical requirements for design, material selection/approval. These specifications often refer to society standards and industrial guidelines. Typical examples in industrial insulation are DIN 4140, AGI Q101, PIP, CINI.

Internal plant owner or contractor specifications

Detailed technical requirements for design, procurement, construction, and related maintenance based on a company's experience (so called best practices), e.g.:

- Shell : DEP
- British Petroleum : BP
- Mobil standards : MS
- Exxon standards : ES

These specifications often refer to industrial guidelines and society standards.

General-specific or site standards

General project or maintenance standards for common materials and equipment adopted by owners and contractors. Often, national, country-specific standards & guidelines are observed, e.g.:

- Saudi Operation Specification: SOS
- Petroleum Development Oman: POD

2.1.2 Insulation specification

The insulation specification is part of the plant owner or contractors specification. It generally contains:

- Guidelines for preparation prior to the insulation work
- Material specifications
- Mounting instructions per application

The insulation specification also often includes the guidelines for corrosion protection. Similar to other specifications, the insulation specification often refers to society standards and/or industrial guidelines.

The detailed lay-out per specification will depend on the type of application, the plant owner, contractor and country specific requirements.

A more detailed explanation of the most common standards, guidelines and specifications is given in the following documents.

- a) CINI Guideline
- b) PIP - guidelines
- c) ASTM standards
- d) European standardisation (CEN)
- e) CE-mark
- f) DIN standards & guidelines
- g) AGI guidelines
- h) BFA WKSB guidelines
- i) FESI guidelines
- j) ISO standards
- k) VDI 2055 guideline
- l) British Standard (BS)
- m) Norme Française (NF)
- n) Document Technique Unifié (DTU)
- o) API Standards
- p) Canadian Standards
- q) MICA Standards
- r) NACE International Standard Practice

The wide variety per country, application and plant owner means these documents cannot convey the entire content and so cannot claim to be complete. For specific applications, please contact our ROCKWOOL Technical Insulation sales team for advice.

a) CINI Guideline

CINI is a Dutch association, in which various companies active in the technical insulation of industrial plants have united to develop uniform material and design guidelines. When compiling these standards, CINI works closely with many decision makers from within the insulation sector.

The CINI Standards are guidelines, yet they do not constitute national standards. Nevertheless, the CINI standards are often adopted by operators and design engineers in the Benelux countries, as well as by international companies operating in the petrochemical industry, for example, Shell. They are often used by operators and design engineers as guidelines on tendering procedures for insulation works. The CINI standards also are grouped into material standards and design rules. The validation of the material properties is based on ASTM and AGI guidelines.

More information is available via www.cini.nl

2.1 Norms & Standards

2.1.2 Insulation specification

Insulation materials (Material standards)	CINI 2.2.01	Stone wool boards: ROCKWOOL (RW) slabs (board) for the thermal insulation of equipment
	CINI 2.2.02	Wired mats: ROCKWOOL (RW) wire mesh blankets for the thermal insulation of large diameter pipes, flat walls and equipment
	CINI 2.2.03	Pipe sections: ROCKWOOL sections and prefabricated elbows for the thermal insulation of pipes
	CINI 2.2.04	Loose wool: Loose rock wool without binder for the thermal insulation of valve boxes and the specification stuffing of insulation mattresses
	CINI 2.2.05	Lamella mats: ROCKWOOL lamella mats for the thermal insulation of air ducts, pipe bundles and equipment
	CINI 2.2.06	Aluminium faced pipe sections: ROCKWOOL sections with reinforced pure aluminium foil facing for the thermal insulation of pipes
Cladding (Material standards)	CINI 3.1.02	Aluminised steel sheeting: Aluminised steel cladding for the finishing of insulation
	CINI 3.1.03	Alu-zinc coated steel sheet: Alu-zinc steel cladding for the finishing of insulation
	CINI 3.1.04	Galvanised steel sheet: Continuous hot dip (Sendzimir) galvanised steel cladding for the finishing of insulation
	CINI 3.1.05	Austenitic stainless steel: Stainless steel cladding for the finishing of insulation
	CINI 3.1.11	GRP: Weather resistant UV-curing glass fibre-reinforced polyester (GRP)
Processing guidelines	CINI 1.3.10	General processing guidelines: Installation instructions for the thermal insulation of hot pipelines and equipment (insulated with mineral wool)
	CINI 4.1.00	Pipes: (Overview) piping insulation details
	CINI 4.2.00	Columns: (Overview) insulation/finishing details overview columns
	CINI 4.3.00	Vessels: (Overview) insulation/finishing detail overview vertical vessels
	CINI 4.4.00	Heat exchangers: (Overview) insulation/finishing details overview horizontal heat exchangers
	CINI 4.5.00	Vessels: (Overview) insulation/finishing details for tanks (operating temperature from 20°C to 180°C)
	CINI 7.2.01	Corrosion protection: Corrosion protection under insulation

b) PIP - guidelines

Process Industry Practices (PIP) is a consortium of mainly US-based process industry owners and engineering construction contractors who serve the industry. PIP was organised in 1993 and is a separately funded initiative of the Construction Industry Initiative (CII) and the University of Texas at Austin. PIP publishes documents called Practices. These Practices reflect a harmonisation of company engineering standards in many engineering disciplines.

Specific Practices include design, selection and specification, and installation information. Some of the best practices are mentioned below.

- INIH1000 - Hot Insulation Installation Details
- INSH1000 - Hot Service Insulation Materials and Installation Specification

More information is available via www.pip.org

c) ASTM standards

ASTM International (ASTM), originally known as the American Society for Testing and Materials, is an international organisation that develops and publishes voluntary standards for a wide range of materials, products, systems and services.

ASTM is older than other organisations for standardisation, such as BSI (1901) and DIN (1917), however it differs from these in that it is not a national standard-setting body. This role is performed in the USA by the ANSI Institute. Nevertheless, ASTM plays a predominant role in the specification of standards in the USA and for many international projects – particularly in the Middle East, Asia and South-America.

The ASTM standards are grouped into materials standards and validation standards for product properties. International tenders for the insulation of industrial plants often refer to relevant ASTM standards.

The ASTM annual book of standards comprises 77 volumes. The corresponding standards for insulation are incorporated into ASTM Volume 04.06 “Thermal insulation; Building and environmental acoustics”. A relevant extract is shown below.

More information is available via www.astm.org

Materials	ASTM C553	Standard specification for mineral fiber blanket thermal insulation for commercial and industrial applications
	ASTM C592	Standard specification for mineral fiber blanket insulation and blanket-type pipe insulation (metal-mesh covered) (industrial type)
	ASTM C547	Standard specification for mineral fiber pipe insulation
	ASTM C612	Standard specification for mineral fiber block and board thermal insulation
	ASTM C1393	Standard specification for perpendicularly oriented mineral fiber roll and sheet thermal insulation for pipes and tanks
Product Properties	ASTM C335	Standard test method for steady-state heat transfer properties of pipe insulation
	ASTM C177	Standard test method for steady-state heat flux measurements and thermal transmission properties by means of the guarded-hot-plate apparatus
	ASTM C411	Standard test method for hot-surface performance of high-temperature thermal insulation
	ASTM E84	Standard test method for surface burning characteristics of building materials
	ASTM C795	Thermal insulation for use in contact with austenitic stainless steel
	ASTM C692	Evaluating the influence of thermal insulations on external stress corrosion cracking tendency of austenitic stainless steel
	ASTM C871	Chemical analysis of thermal insulation materials for leachable chloride, fluoride, silicate and sodium ions
	ASTM C1104/ C1104M	Determining the water vapor sorption of unfaced mineral wool fiber insulation
Thermal Calculations	ASTM C680	Standard practice for estimate of the heat gain or loss and the surface temperatures of insulated flat, cylindrical, and spherical systems by use of computer programs
	ASTM C1129	Standard practice for estimation of heat savings by adding thermal insulation to bare valves and flanges
Covering	ASTM C1423	Standard guide for selecting jacketing materials for thermal insulation
	ASTM C921	Standard practice for determining properties of jacketing materials for thermal insulation
Other	ASTM C585	Standard practice for inner and outer diameters of thermal insulation for nominal sizes of pipe and tubing
	ASTM C929	Standard practice for handling, transporting, shipping, storage, receiving, and application of thermal insulation materials for use in contact with austenitic stainless steel
	ASTM C1696	Standard Guide for Industrial Thermal Insulation Systems

2.1 Norms & Standards

2.1.2 Insulation specification

d) European standardisation (CEN)

In order to remove technical barriers to trade, the European Union decided to develop uniform European product standards. These product standards describe the product properties, as well as the methods of testing for these properties. The minimum requirements for certain product properties still remain a national responsibility and are laid down in each individual country. The EU issues orders in the form of mandates to CEN (the European Committee for Standardisation), which the CEN uses to develop relevant standards.

For stone wool, this product standard is the EN 14303 “Thermal insulation products for building equipment and industrial installations – Factory-made mineral wool (MW) products – specification”. Following ratification, a European standard must be adopted as it stands by the national standardization organizations as a national standard. Deviating national standards must be retracted. Each European standard adopted is published in each EU country with a national prefix, e.g. in Germany: DIN-EN-XXXX; in England (British Standard): BS-EN-XXX.

Product properties, test standards

Product property	Standard	Description
Thermal conductivity (Piping)	EN ISO 8497	Heat insulation – Determination of steady-state thermal transmission properties of thermal insulation for circular pipes
Thermal conductivity (Boards)	EN 12667	Thermal performance of building materials and products – Determination of thermal resistance by means of guarded hot plate and heat flow meter methods - Products of high or medium thermal resistance
Water vapour diffusion resistance coefficient	EN 12086	Thermal insulating products for building applications – Determination of water vapour transmission properties
AS quality	EN 13468 Replaces AGI guideline Q135	Thermal insulation products for building equipment and industrial installations – Determination of trace quantities of water-soluble chloride, fluoride, silicate, sodium ions and pH
Hydrophobic treatment	EN 13472 (for piping) and EN 1609 (flat products) are replacing AGI Guideline Q136	Thermal insulating products for building equipment and industrial installations – Determination of short-term water absorption by partial immersion of preformed pipe insulation
Maximum service temperature	EN 14706 (for flat products) EN 14707 (for piping)	Thermal insulating products for building equipment and industrial installations – Determination of maximum service temperature Thermal insulating products for building equipment and industrial installations – Determination of maximum service temperature for preformed pipe insulation
Compression resistance	EN 826	Thermal insulating products for building applications – Determination of compression behaviour
Air flow resistance	EN 29053 Determination of airflow resistance	Acoustics; Materials for acoustical applications; Determination of airflow resistance (ISO 9053:1991)

e) CE-mark

The CE marking as it is legally called since 1993 (per directive 93/68/EEC) (abbreviation of French: Conformité Européenne, meaning "European Conformity" is a mandatory conformity mark for products placed on the market in the European Economic Area (EEA). With the CE marking on a product the manufacturer ensures that the product conforms with the essential requirements of the applicable EC directives. Legally, the CE marking is no quality mark. But from August 2012 on, only technical insulation products which comply with the European product standards (see 2.1.2d) and bear the CE mark may be sold in Europe. A mandatory frame-work will then apply for the key product features of technical insulation materials – such as thermal conductivity, resistance to water vapour transmission, fire behaviour, tolerances etc. The performance of a mineral wool product is summarized in a designation code, which can be found on the labels of the individual products. E.g. for mineral wool: MW EN 14303-T2-ST(+)-680-WS1-CL10

- T2 = Thickness tolerance
- ST = Maximum service temperature
- CS = Compressive strength
- WS = Water absorption
- CL = Trace quantities of water soluble chloride

The main advance of the CE-mark and related European standards is that a higher level of transparency is achieved. This will allow specifiers, distributors and installers to make a quick and direct comparison between the available products in today's market place.

f) DIN standards & Guidelines

Deutsches Institut für Normung e.V. (DIN; in English, the German Institute for Standardization) is the German national organisation for standardisation and is that country's ISO member body. DIN is a registered association (e.V.), founded in 1917, originally as Normenausschuss der deutschen Industrie (NADI, Standardization Committee of German Industry). In 1926, the NADI was renamed Deutscher Normenausschuss (DNA, German Standardization Committee) in order to indicate that standardisation covered many fields, not just industrial products.

In 1975 the DNA was finally renamed DIN. Since 1975, it has been recognised by the German government as the national standards body and represents German interests at international and European level.

The acronym DIN is often wrongly expanded as Deutsche Industrienorm (German industry standard). This is largely due to the historic origin of the DIN as NADI. The NADI indeed published their standards as DI-Norm (Deutsche Industrienorm, German industry standard).

Designation

The designation of DIN standards shows its origin.

- DIN # is used for German standards with primarily domestic significance or designed as a first step toward international status.
- E DIN # is a draft standard and DIN V # is a preliminary standard.
- DIN EN # is used for the German edition of European standards.
- DIN ISO # is used for the German edition of ISO standards.
- DIN EN ISO # is used if the standard has also been adopted as a European standard.

DIN standards for the validation of insulation materials can be found under European standards. DIN 4140 "Insulation work on industrial installations..." gives guidelines for the validation of insulation material, mounting and fixing. This standard applies to insulation works on industrial plants. These are production and distribution plants for the industry and for technical building appliances, (e.g. appliances, vessels, columns, tanks, steam generators, pipes, heating and ventilation systems, air conditioning units, refrigeration units and hot water installations). With requirements relating to fire protection, the relevant standards or national technical approvals must be observed. This standard does not apply to insulation works performed on building shells, interior walls and inserted ceilings, neither in the shipbuilding and vehicle manufacturing industry, nor within the control area of power plants.

2.1 Norms & Standards

2.1.2 Insulation specification

g) AGI

"Arbeitsgemeinschaft Industriebau e.V.". (AGI) is a German association of manufacturers, engineering companies and universities. AGI was founded in 1958 to establish a common platform to exchange best practices within Industry. These practices, which are summarised in the

AGI guidelines (so called "Arbeitsblätter") are established in cooperation with the German DIN, VDI and CEN members for insulation. The most relevant standard for insulation work is shown on the next page.

More information is available via www.agi-online.de.



h) BFA WKSB

"Deutsche Bauindustrie" is a German branch organization within the building & construction industry. Part of this organization is the so called Bundes Fach Abteilungen (BFA) - "technical departments" who are specialized in the technological developments and lobby activities within a specific area of technical expertise. One of them, the so called "BFA WKSB" (Bundes Fach Abteilung Wärme-, Kälte-, Schall-und Brand Schutz), represents the branche members' interests in industrial insulation, acoustic insulation and fire proofing in buildings. As well as lobbying towards the various organizations and the German government, they recommend best practices and provisions as stated in the so called technical letters. These practices are established in cooperation with DIN, AGI, CEN, FESI and testing bodies like FIW. The most important technical letters for hot insulation are shown below.

Technical Letter	Field of application/scope
1	Problems of thermal stress in metal reinforcements of large-dimensional object with elevated service temperatures
3	Prevention of metal corrosion
4	System for measurement and recording for industrial insulation cladding.
5	Problems with the warranty of specified surface temperatures
6	High profitability through ecologically based insulation thicknesses
9	Methods of measuring
10	Measuring point for thermal insulation
11	Moisture in insulation systems

More information is available via www.bauindustrie.de

i) FESI

FESI, Fédération Européenne des Syndicats d'Entreprises d'Isolation is the European Federation of Associations of Insulation Companies. FESI was founded in 1970 and is the independent European Federation representing the insulation contracting sector. FESI promotes insulation as one of the best, the most cost effective and sustainable manners to save energy. FESI represents the insulation associations from 16 European countries whose members are active in insulation for industry, commercial building sectors, ship insulation, soundproofing, fire protection and others. The most important FESI documents (guidelines, recommendations) are shown below.

Document	Description
04	Working Manual: System for measurement and recording for industrial insulation cladding (English translation of BFA WKSB letter no. 4 and 2).
05	Problems associated with the warranty of specified surface temperature. (English translation of BFA WKBS, technical letter no. 5)
06	"High profitability through ecologically based insulation thicknesses". (English translation of BFA WKBS, technical letter no. 6)
09	"Principles of metal corrosion". (English translation of BFA WKBS, technical letter no. 3 and 2)
A1	A industrial Acoustics – B Building acoustics – Code of Guarantee
11	"Problems of thermal stress in metal reinforcements of large-dimensional objects with elevated service temperatures". (English translation BFA WKSB technical letter Nr. 1, 2.)
A2	Basics of Acoustics
A3	"Product characteristics " Acoustic insulation, absorption, attenuation

More information is available via www.fesi.eu

2.1 Norms & Standards

2.1.2 Insulation specification

j) ISO

The International Organization for Standardization (Organisation internationale de normalisation), widely known as ISO, is an international-standard-setting body composed of representatives from various national standards organizations. Founded on 23 February 1947, the organisation promulgates world-wide proprietary industrial and commercial standards. It is headquartered in Geneva, Switzerland.[1]. While ISO defines itself as a non-governmental organization, its ability to set standards that often become law, either through treaties or national standards, makes it more powerful than most non-governmental organizations. In practice, ISO acts as a consortium with strong links to governments. Most of the ISO standards for insulation focus on the testing of material properties and are embedded in, for instance, EN standards.

More information is available via www.iso.org

k) VDI 2055

Verein Deutscher Ingenieure (VDI) (English: Association of German Engineers) is an organisation of engineers and natural scientists. Established in 1856, today the VDI is the largest engineering association in Western Europe. The role of the VDI in Germany is comparable to that of the American Society of Civil Engineers (ASCE) in the United States. The VDI is not a union. The association promotes the advancement of technology and represents the interests of engineers and of engineering businesses in Germany.

VDI 2055 is the most important guideline for technical insulation. The scope of the guideline includes heat and cold insulation of technical industrial plants and technical building equipment, such as pipes, ducts, vessels, appliances, machines and cold stores. The minimum

insulation thicknesses for heat distribution and warm water pipes in technical building equipment with respect to Germany, are laid down in the regulations concerning energy-saving heat insulation and energy-savings in buildings (EnEV Energy Saving Ordinance). The considerations expressed in this guideline may lead to other insulation thicknesses. With regard to heat insulation in the construction industry, both the EnEV and DIN standard 4108. Legal requirements must be observed with regard to the fire performance of insulation and the fire resistance classes of insulation, such as federal state building regulations [Landesbauordnungen] and the piping system guidelines of the federal states [Leitungsanlagen-Richtlinien der Bundesländer].

The VDI guideline 2055 also serves as a benchmark for **thermo technical calculations** and measuring systems in relation to industrial and building services installations and for guarantees and conditions of supply with regard to those installations. The guideline covers in detail the calculation of heat flow rates, the design of the insulation thickness according to operational and economic aspects, the technical warranty certificate and the technical conditions in respect of delivery quantities and services. Furthermore, the guideline examines measuring systems and testing methods (for quality assurance).

The VDI 2055 consists of:

- Part 1: Bases for calculation
- Part 2: Measuring, testing and certification of insulation materials
- Part 3: Conditions of supply and purchasing of insulation systems

I) British standard

British Standards are produced by BSI British Standards, a division of BSI Group that is incorporated under a Royal Charter and is formally designated as the National Standards Body (NSB) for the UK. The standards produced are titled British Standard XXXX[-P]:YYYY where XXXX is the number of the standard, P is the number of the part of the standard (where the standard is split into multiple parts) and YYYY is the year in which the standard came into effect. British Standards currently has over 27,000 active standards.

The following table provides an overview of the standards and regulations that must be taken observed when insulating industrial plants with ROCKWOOL insulation. On the one hand, they are grouped according to product and material standards, which establish the different insulation properties, and on the other hand, according to validation and design rules.

Standard	Description
BS 5970: Code of practice for thermal insulation of pipework and equipment in the temperature range of -100°C to +870°C	This British Standard code of practice describes aspects of thermal insulation for pipework and equipment in the temperature range -100 degrees C to +870 degrees C. The installation techniques described in this standard can be used outside the temperature range indicated, however, it is recommended that for such applications specialist advice is sought. This standard explains the basic principles that should be followed in selecting insulating systems for specific requirements.
BS 5422: Method for specifying thermal insulating materials for pipes, tanks, vessels, ductwork and equipment operating within the temperature range -40°C to +700°C	This British Standard describes a method for specifying requirements for thermal insulating materials on pipes, tanks, vessels, ductwork and equipment for certain defined applications and conditions within the temperature range -40 degrees C to +700 degrees C. It gives the recommended thickness and required performance of thermal insulation material for various applications.
BS 1710 Specification for identification of pipelines and services	Colours for identifying pipes conveying fluids in liquid or gaseous condition in land installations and on board ships. Colour specifications in accordance with BS 4800.
BS 3958-Part 4: Thermal insulating materials. Bonded preformed man-made mineral fibre pipe sections	Physical and chemical requirements, dimensions and finishes for pipe sections generally for use at elevated temperatures."
BS 3958-Part 3: Thermal insulating materials. Metal mesh faced man-made mineral fibre mattresses	Specifies composition, moisture content, physical and chemical requirements for mineral fibre mattresses, faced on one or both sides with flexible metal mesh.
BS 3958-Part 5: Thermal insulating materials. Specification for bonded man-made mineral fibre slabs	Composition, moisture content, physical and chemical requirements, and standard sizes. Products are divided into four groups according to thermal conductivity and temperature range.

2.1 Norms & Standards

2.1.2 Insulation specification

Test methods

BS 476-4 Fire test on building materials	Part 4, Non combustibility test for materials Part 6, Methods of test for fire propagation of products Part 7, Method for classification of the surface spread of flame products
BS EN 13467 Thermal insulating products for building equipment and industrial installations	Determination of dimensions, squareness and linearity of preformed pipe insulation
BS EN 13468 Thermal insulating products for building equipment and industrial installations	Determination of trace quantities of water soluble chloride, fluoride, silicate, sodium ions and pH
BS EN 13469 Thermal insulating products for building equipment and industrial installations	Determination of water vapour transmission properties of preformed pipe insulation
BS EN 13470 Thermal insulating products for building equipment and industrial installations	Determination of the apparent density of preformed pipe insulation
BS EN 13471 Thermal insulating products for building equipment and industrial installations	Determination of the coefficient of thermal expansion
BS EN 13472 Thermal insulating products for building equipment and industrial installations	Determination of short term water absorption by partial immersion of preformed pipe insulation
BS EN 12664 Thermal performance of building materials and products	Determination of thermal resistance by means of guarded hot plate and heat flow meter methods. Dry and moist products of medium and low thermal resistance
BS EN 12667 Thermal performance of building materials and products	Determination of thermal resistance by means of guarded hot plate and heat flow meter methods. Products of high and medium thermal resistance
BS EN 12939 Thermal performance of building materials and products	Determination of thermal resistance by means of guarded hot plate and heat flow meter methods. Thick products of high and medium thermal resistance

m) NF (Norme Française) mark

The NF mark is an official French quality mark, issued by the Association Française de Normalisation (French Association for Standardization, AFNOR), which certifies compliance with the French national standards. The use of the NF mark has been entrusted to AFNOR Certification (a subsidiary of the AFNOR Group).

The NF quality mark is not a trademark as such, but is a collective certification mark. It carries undisputable proof that a product satisfies the safety and/or quality specifications defined within the corresponding certification standard.

More information is available via www.afnor.org

This standard consists of:

- French, European or international standards
- Supplementary specifications regarding the product or service and the quality system in place in the company as comprised in the certification rules, specific to each product or service.

The certification standards are drawn up in collaboration with all relevant stakeholders: manufacturers or service providers, trade organisations, consumers, public authorities and technical bodies. Compliance with French standards is mandatory in France for all supply or construction contracts for public authorities (government contract).

General	NF EN ISO 7345	Thermal insulation – Physical quantities and definitions
	NF EN ISO 9251	Thermal insulation – Heat transfer conditions and properties of materials - Vocabulary
	NF EN ISO 9288	Thermal insulation – Heat transfer by radiation – Physical quantities and definitions
	NF EN ISO 8497	Thermal insulation – Determination of steady-state thermal transmission properties of thermal insulation for circular pipes
	NF EN ISO 9229	Thermal insulation – Vocabulary
	NF EN ISO 12241	Thermal insulation for building equipment and industrial installations – Calculation rules
Property	NF EN ISO 13787	Thermal insulation products for building equipment and industrial installations – Determination of declared thermal conductivity
	NF EN 12667	Thermal performance of building materials and products – Determination of thermal resistance by means of guarded hot plate and heat flow meter methods – Products of high and medium thermal resistance
	NF EN ISO 8497	Thermal insulation - Determination of steady-state thermal transmission wproperties of thermal insulation for circular pipes
	NF EN 12939	Thermal performance of building materials and products – Determination of thermal resistance by means of guarded hot plate and heat flow meter methods – Thick products of high and medium thermal resistance
	NF EN 14303	Thermal insulation products for building equipment and industrial installations - Factory made mineral wool (MW) products – Specification
Test standard	NF EN 1609	Thermal insulating products for building applications - Determination of short term water absorption by partial immersion
	NF EN 13472	Thermal insulating products for building equipment and industrial installations – Determination of short term water absorption by partial immersion of preformed pipe insulation
	NF EN 12086	Thermal insulating products for building applications – Determination of water vapour transmission properties
	NF EN 12087	Thermal insulating products for building applications - Determination of long term water absorption by immersion
	NF EN 14706	Thermal insulating products for building equipment and industrial installations - Determination of maximum service temperature
	NF EN 14707	Thermal insulation products for building equipment and industrial installations - Determination of maximum service temperature for preformed pipe insulation
	NF EN 1602	Thermal insulating products for building applications – Determination of the apparent density
	NF EN 826	Thermal insulating products for building applications – Determination of the apparent density
	NF EN 13468	Thermal insulation products for building equipment and industrial installations - Determination of trace quantities of water soluble chloride, fluoride, silicate, sodium ions and pH
Insulating material	NF EN 13162	Thermal insulation products for buildings – Factory made mineral wool (MW) products – Specification
	NF P75-101	Thermal insulation for building purposes – Definition
Assembly	NF EN 12213	Cryogenic vessels – Methods for performance evaluation of thermal insulation
Covering	NF EN 485	Aluminium and aluminium alloys – Sheet, strip and plate - Part 1 - 4
	NF EN 10088-2	Stainless steels – Technical delivery conditions for sheets and strips of corrosion resistant steels for general purposes. Part 1-5

* Please consult the other parts for further details regarding corrosion protection of steel structures.

2.1 Norms & Standards

2.1.2 Insulation specification

n) Unified Technical Document (Document Technique Unifié, DTU)

Object and scope of the DTUs

A DTU comprises a list of contractual technical stipulations applicable to construction work contracts. The specific documents included in the works contract, in accordance with the specifications for each individual project, must specify all of the required provisions that are not outlined within the DTU, or all those deemed relevant for inclusion by the contracting parties, as a complement to or in deviation from those specified in the DTU.

In particular, the DTUs are generally unable to suggest technical provisions for performing work on buildings constructed using outdated techniques.

The establishment of technical clauses for contracts of this type results from a reflection on the part of those parties who are responsible for designing and implementing the work. Where it proves to be pertinent, these clauses are based on the content of the DTU, as well as on all knowledge acquired in practice in relation to these outdated techniques. The DTUs refer to construction products or procedures for the execution of works, the ability of which to satisfy the technical provisions of the DTUs is known through experience.

Where this document refers to that effect to a Technical Evaluation or Technical Application Document, or to a product certification, the contractor may suggest products to the contracting authority that benefit from current testing methods in other Member States of the European Economic Area, which they deem to be comparable and which are certified by accredited organisations, by the organisations that are signatories to 'E.A.' agreements, or in the absence thereof, which evidence their compliance with the EN 45011 standard. The contractor must then supply the contracting authority with the evidence needed in order to evaluate the comparability. The conditions under which the contracting authority shall accept such an equivalent are defined within the Contract Bill of Special Clauses of this DTU.

More information is available via www.afnor.org

o) API Standards

API (American Petroleum Institute) is a trade association focused on the Oil & Gas industry. They have developed standards and practices that have an influence on design. Some of the common standards that relate to insulation are mentioned below:

API 521 - Pressure-relieving and Depressuring Systems
API 583 Corrosion Under Insulation and Fireproofing

More information is available via www.api.org

p) Canadian Standards

The SCC (Standards Council of Canada) mandate is to promote efficient and effective voluntary standardization in Canada, in particular, to promote, oversee and coordinate efforts of people and organizations involved in the National Standards System.

In Canada (as in the US) accredited bodies such as CSA (Canada Standards Association) and CAN/ULC (Underwriters Laboratory) produce consensus based standards that can be adopted by various regulatory bodies. ASTM standards are widely used in Canada (see Chapter 2.1.2 on ASTM standards).

Most commonly used standard in Industrial/Mechanical applications is CAN/ULC S114 (Non-combustibility) and S102 (Surface Burning Characteristics).

Provincial building codes based on the model National Building Code of Canada (NBCC) regulate the general construction of buildings, including industrial buildings housing process equipment.

More information is available via www.scc.ca

q) MICA Standards

First published in 1979 by MICA (Midwest Insulation Contractors Association), the Standards Manual has received wide acceptance throughout the United States and other countries. It has

established standardized guides never before available to our field for methods of designing, specifying and installing thermal insulation products. The 7th edition of the National Commercial & Industrial Insulation Standards continues to be the national source of technical information for the design specification and installation of commercial and industrial insulation.

More information is available via www.micainsulation.org

r) NACE International Standard Practice

NACE International - The Corrosion Society serves nearly 33,000+ members in 116 countries and is recognized as the premier authority for corrosion control solutions. The organization offers technical training and certification programs, conferences, industry standards, reports, publications and more. NACE standards represent a consensus of those individual members who have reviewed the documents, their scope, and their provisions. NACE Standard Practice SP0198-2010 "Control of Corrosion Under Thermal Insulation and Fireproofing Materials - A System Approach" provides the current technology and industry practices for mitigating corrosion under thermal insulation and fireproofing materials, a problem termed Corrosion Under Insulation (CUI).

More information is available via www.nace.org

2. Theory

2.1.3 Relevant guidelines & standards for the industrial/mechanical insulation industry in North America

In North America there are no regulations or codes governing the design and installation of industrial/mechanical insulation. Best practices is generally adopted following a variety of different standards & guidelines published by bodies such as ASTM, NACE, MICA & PIP.

Many ownership groups in North America have developed their own internal standards and guidelines which are used throughout various projects. The intention of the PIP guidelines is to consolidate these internal standards from ownership groups to create a uniform approach.

The commonly referred to standards and guidelines in North America include:

ASTM C1696

NACE SP0198

MICA National Commercial & Industrial Insulation Standards

In addition, ASTM and CAN/ULC material, property and compliance standards are also important. Refer to ASTM chart on page 99. In Canada, CAN/ULC S102 and S114 are referred to for surface burning characteristics and non-combustibility. General building insulation requirements are covered by state and provincial building codes and standards. Keep in mind that ANSI along with other organizations and societies (e.g. NACE and ASME) may impact other aspects of the system being insulated (e.g. ASME Boiler and Pressure Vessel Code).

2.1.4 Relevant guidelines & standards for the industrial/mechanical insulation industry in Europe

Refer to 2.1.2 Insulation specification d) European standardisation (CEN) and e) CE mark on pages 100 and 101 in this chapter.

2.1.5 Relevant guidelines & standards

for the technical insulation industry in Germany

The German system of standards and regulations is primarily composed of the following constituents: DIN (German Institute for Standardisation) standards, VDI (Association of German Engineers) guidelines, AGI (German Working Group for Industrial Construction) working documents, VDI quality assurance, and RAL (German Institute for Quality Assurance and Certification) quality marks. Furthermore, there are additional regulations for special fields of application, such as working standards on the part of the operator, which must be observed. Most of the standards, regulations and guidelines are adapted within the local project specifications.

The following table shows an overview of the standards and regulations that must be observed when insulating industrial plants with ROCKWOOL insulation. On the one hand, they are grouped according to product and material standards, which establish the different insulation properties, and on the other hand, according to validation and design rules.

Material standards and design guidelines	Field of application/scope
AGI Q02: Insulation works on industrial installations – Terms	The terms used in the AGI Q working documents are defined in this working document.
AGI Q03: Construction of thermal and cold insulation systems – Insulation works of industrial plants	This working document applies to insulation works performed on industrial installations. The working document classifies works into thermal insulation works for operating temperatures above the ambient temperature and cold insulation works for operating temperatures below the ambient temperature.
AGI Q05: Construction of industrial plants – Bases, design, requirements with regard to the interfaces of plant components and insulation	This working document has been compiled for planners and designers that have to design the industrial plants, including the essential thermal or cold insulation. It examines in particular the interfaces between plant construction and insulation.
AGI Q101: Insulation works on power plant components – Construction	Working document Q 101 applies to insulation works performed on power plant components such as steam generators and flue gas cleaning systems, pipe systems and steel flues.
AGI Q103: Insulation works on industrial plants – Electrical tracing	This working document applies to insulation works performed on industrial plants with electrical tracing.
AGI Q104: Insulation works on industrial plants – Tracing systems with heat transfer media	This working document applies to insulation works performed on industrial installations, which are heated and/or cooled by means of heat transfer and/or refrigerant media, for example in tracing pipes or half pipe sections.
AGI Q132: Rock wool as insulation for industrial plants	This working document applies to rock wool insulation, which is used for thermal, cold and acoustic insulation of technical industrial plants and technical building appliances.
AGI Q151: Insulation works – Protecting thermal and cold insulation systems on industrial plants against corrosion	This working document applies to corrosion protection coating systems for the surfaces of industrial plants, such as appliances, columns and pipes, which are insulated against heat and cold loss. Since the DIN EN ISO 12944 standard provides no explanations with regard to protecting insulation systems against corrosion, this working document should be considered as a supplement to standard DIN EN ISO 12944. This working document does not apply in respect of adhesive primers.
AGI Q152: Insulation works on industrial plants – Protection against moisture penetration	This AGI working document applies to objects where the insulation must be protected against moisture and, above all, against the ingress of liquids, (e.g. water, heat transfer oil).
AGI Q153: Insulation works on industrial plants – Mounting supports for support constructions	AGI working document Q 153 applies to the design and construction of mounting supports. They transfer the loads of the insulation onto the support constructions on the object.
AGI Q154: Insulation works on industrial plants – support constructions	AGI working document Q 154 applies to the construction of support constructions.

2.1 Norms & Standards

2.1.5 Relevant guidelines & standards for the technical insulation industry in Germany

<p>DIN 4140: Insulation works on technical industrial plants and technical building appliances – Construction of thermal and cold insulation systems</p>	<p>This standard applies to insulation works on industrial plants. These are production and distribution plants for the industry and for technical building appliances, (e.g. appliances, vessels, columns, tanks, steam generators, pipes, heating and ventilation systems, air conditioning units, refrigeration units and hot water installations). In the event of requirements with regard to fire protection, the relevant standards or national technical approvals must be taken into account. This standard does not apply to insulation works performed on building shells, interior walls and inserted ceilings, neither in the shipbuilding and vehicle manufacturing industry, nor within the control area of power plants.</p>
<p>VDI 2055: Thermal and cold insulation of technical industrial plants and technical building equipment</p>	<p>The scope of the guideline includes heat and cold insulation of technical industrial plants and technical building equipment, such as pipes, ducts, vessels, appliances, machines and cold stores. The minimum insulation thicknesses for heat distribution and warm water pipes in technical building equipment are laid down with respect to Germany in the regulations concerning energy-saving heat insulation and energy-saving plant engineering in buildings (Energy Saving Ordinance) [Energieeinsparverordnung, EnEV]. The considerations expressed in this guideline may give rise to other insulation thicknesses. With regard to heat insulation in the construction industry, both the Energy Saving Ordinance and DIN standard 4108. Legal requirements must be taken into consideration with regard to the fire performance of insulation and the fire resistance classes of insulation, such as federal state building regulations [Landesbauordnungen] and the piping system guidelines of the federal states [Leitungsanlagen-Richtlinien der Bundesländer].</p> <p>The VDI guideline 2055 serves as a benchmark for thermo technical calculations and measuring systems in relation to industrial and building services installations and for guarantees and conditions of supply with regard to those installations. The guideline covers in detail the calculation of heat flow rates, the design of the insulation thickness according to operational and economic aspects, the technical warranty certificate and the technical conditions in respect of delivery quantities and services. Furthermore, the guideline examines measuring systems and testing methods (for quality assurance purposes also). The VDI 2055 guideline consists of 3 parts:</p> <ul style="list-style-type: none">Part 1: Bases for calculationPart 2: Measuring, testing and certification of insulation materialsPart 3: Conditions of supply and purchasing of insulation systems

The following table cites a number of important test standards for the product properties of insulation materials.

a) Test standards (Germany)

Building material class (Fire performance)	DIN 4102-1	Fire performance of building materials and building components – Part 1: Building materials, terms, requirements and tests
Melting point	DIN 4102-17	Fire performance of building materials and building components – Part 17: Melting point of rock wool insulations
Thermal conductivity (Piping)	DIN EN ISO 8497	Heat insulation – Determination of steady-state thermal transmission properties of thermal insulation for circular pipes
Thermal conductivity (Boards)	DIN EN 12667	Thermal performance of building materials and products – Determination of thermal resistance by means of guarded hot plate and heat flow meter methods - Products of high or medium thermal resistance
Water vapour diffusion resistance coefficient	DIN EN 12086	Thermal insulating products for building applications – Determination of water vapour transmission properties
AS quality	DIN EN 13468 Replaces AGI Q135	Thermal insulation products for building equipment and industrial installations – Determination of trace quantities of water-soluble chloride, fluoride, silicate, sodium ions and pH
Hydrophobic treatment	DIN EN 13472 Replaces AGI Q136	Thermal insulating products for building equipment and industrial installations – Determination of short-term water absorption by partial immersion of preformed pipe insulation
Maximum service temperature	DIN EN 14706 (for flat products)	Thermal insulating products for building equipment and industrial installations – Determination of maximum service temperature
	DIN EN 14707 (for piping)	Thermal insulating products for building equipment and industrial installations – Determination of maximum service temperature for preformed pipe insulation
Absence of silicon	According to VW test 3.10.7	This test procedure verifies whether the insulation is free from paint wetting impairment substances (e.g. silicon)
Compression resistance	DIN EN 826	Thermal insulating products for building applications – Determination of compression behaviour
Air flow resistance	DIN EN 29053 Determination of airflow resistance	Acoustics; Materials for acoustical applications; Determination of airflow resistance (ISO 9053:1991)

2.1 Norms & Standards

2.1.5 Relevant guidelines & standards for the technical insulation industry in Germany

b) Insulation code number according to AGI Q132

AGI guideline Q132 lays down the material properties and the requirements that are imposed on mineral wool insulation for industrial installations. The insulation materials are denoted with a ten-figure code number (so called "Dämmstoffkennziffer"), consisting of five pairs

of digits. In this case, the first pair of digits "10" represents rock wool. The further pairs of digits represent the:

- Delivery form
- Thermal conductivity group
- Longitudinal air flow resistance
- Apparent density group

Rock wool insulation		Delivery form		Thermal conductivity		Longitudinal air flow resistance		Declared apparent density	
Group	Type	Group	Form	Group	Delivery form	Group	kPa s/m ²	Group	kg/m ³
10	Mineral wool	01	Wired mats	01	Limit curve 1	05	5	01	10
		02	Lamella mats	02	Limit curve 2	10	10	02	20
		03	Lamella mats load-bearing	03	Limit curve 3	20	20	03	30
		04	(Pipe) sections	04	Limit curve 4	30	30	04	40
		05	Pipe segments boards	05	Limit curve 5	40	40	05	50
		06	Felts, mats	06	Limit curve 4	50	50	06	60
		07	Slabs	07	Limit curve 5	60	60	07	70
		08	Form pieces	08	Limit curve 5	70	70	08	80
		09	Loose wool	09	Limit curve 5	80	80	09	90
						90	>90	10	100
						99	* N.I.	11	110
								12	120
								13	130
								•	•
								18	180
								99	* N.I.

* N.I.: no information.

Using ProRox wired mat with a density of 80kg/m³ as an example results in the following insulation code:

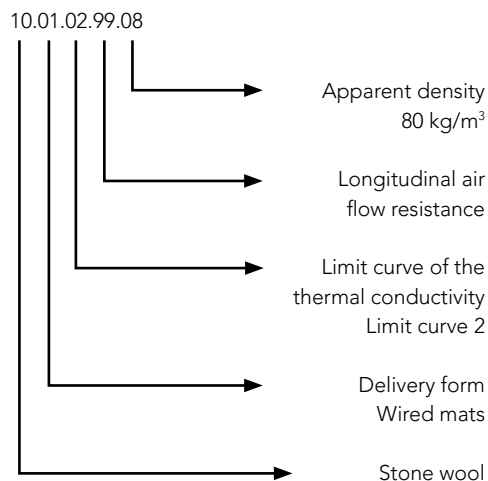

c) European standardisation

In order to remove technical barriers to trade, the European Union decided to develop uniform European product standards. These product standards describe the product properties, as well as the methods of testing for these properties. The minimum requirements for certain product properties still remain a national responsibility and are laid down in each individual country. The EU issues orders in the form of mandates to CEN (the European Committee for Standardisation), which the CEN uses to develop relevant standards.

The majority of orders have now been commissioned and initial harmonised standards, such as the insulation standards for structural engineering (DIN EN 13262), have been published. The European product standards for technical insulation are currently being compiled. For stone wool, this product standard is the EN 14303 "Thermal insulation products for

building equipment and industrial installations – Factory-made mineral wool (MW) products – specification".

Each European standard adopted is published in each EU country with a national prefix, e.g. in Germany: DIN-EN-XXXX; in England (British Standard): BS-EN-XXX.

d) Quality Assurance

It is essential that, in addition to the design quality, the product properties guaranteed by the insulation manufacturer, for example, the thermal conductivity or temperature resistance, are adhered to during processing in order to guarantee the faultless operation of a thermal or cold insulation constructed according to operational and economic criteria. Well-known insulation manufacturers guarantee this through extensive internal and external quality control. The VDI 2055 guideline "Thermal and cold insulation of industrial installations and building equipment" regulates this voluntary quality assurance.

The VDI 2055 quality assurance of insulation products is classified as a quality control, consisting of an external and internal quality control, as well as a certification of insulation materials for industrial installations. The property values specified on the product data sheets, prospectuses or price lists of the manufacturer, such as the thermal conductivity or maximum service temperature for example, form the basis for the quality control. As a result, a user or producer of VDI 2055 quality assured insulation products can safely assume that even publicised property values are subject to a quality control. When the product conforms to the properties specified by the manufacturer in the product data sheets, the certification body grants the manufacturer the right to use the certification mark "Checked in accordance with VDI 2055".

2.1 Norms & Standards

2.1.5 Relevant guidelines & standards for the technical insulation industry in Germany

The following text outlines the product properties that must, at the very least, be controlled in the case of a mineral wool insulation product, in order for the VDI 2055 inspection mark to be granted:

- Thermal conductivity as a curve ($\lambda = f(t)$ or $f(t_m)$)
- Dimensions (length, width, depth)
- Apparent density
- Maximum service temperature

In addition, the following product properties are usually controlled externally:

- Fire performance
- Hydrophobic properties
- Water-soluble chloride content (AS quality)

Internal quality control

The manufacturer takes samples during production and tests for the relevant product properties. For properties such as thermal conductivity, indirect measurement methods can also be used. The manufacturer must have a quality management procedure in place, which instigates the measures required to rectify the defect in the event of deviations from the reference values.

External quality control

For the purposes of external quality control in accordance with VDI 2055, the manufacturer must enter into a supervision contract with a leading testing body, such as the FIW (Research Institute for thermal insulation materials).

The external quality control is made up of the following elements:

- Auditing of the internal quality control
- Verification of the labelling of the products
- Product testing

Certification

Upon correct implementation of the internal and external quality control of insulation products

manufactured according to VDI 2055, DIN CERTCO developed a certificate with regard to conformity to VDI 2055, to the data sheets of the VDI AG "Quality Control" and to the technical data of the manufacturer.

e) RAL quality mark

ROCKWOOL stone wool insulation products bear the RAL quality mark. They are therefore subject, in addition to the stringent criteria of the quality assessment and test specifications of the Mineral Wool Quality Community [Gütegemeinschaft Mineralwolle e. V.], to continuous inspections, which guarantee compliance with the criteria of the German legislation governing hazardous substances and with the EU directive. In accordance with both the German and European standards, bio-soluble ROCKWOOL stone wool offers outstanding thermal, cold, acoustic and fire protection whilst meeting a high safety standard.

f) No prohibition on manufacture and usage

The German federal government has laid down criteria for the appraisal of mineral wool insulation products in the Ordinance on Hazardous Substances [Gefahrstoffverordnung] and the Chemicals Prohibition Ordinance [Chemikalien-Verbotsverordnung]. Products not meeting these criteria cannot be manufactured and used in Germany. ProRox stone wool insulation products fulfil these requirements. The prohibition on manufacture and usage does not apply to ProRox stone wool insulation products. Studies have shown that stone wool is a safe product to live and work with; it is amongst the most well-documented and tested of all building materials. A Safe Use Instruction Sheet (SUIS) from ROCKWOOL Technical Insulation Group is available upon request.

2.1.6 Relevant guidelines & standards for the technical insulation industry within the Benelux

The local system of standards and regulations in the Netherlands and Belgium focuses primarily on building construction. The Dutch CINI manual is adopted as a general guideline for mounting and fixing by the majority of industry owners and construction engineers. Product testing often refers to AGI, DIN and European standards. Refer to the previous chapters for more information.

2. Theory

2.2 Product properties & test methods

The requirements for technical insulation are high and varied. Piping, boilers, storage tank require insulation materials with particular properties. Although the application and type of products may vary, the basic definition of all product properties is the same.

- 2.2.1 Fire behaviour
- 2.2.2 Thermal conductivity
- 2.2.3 Maximum service temperature
- 2.2.4 Water leachable chloride content
- 2.2.5 Water repellency
- 2.2.6 Water vapour transmission
- 2.2.7 Longitudinal air flow resistance
- 2.2.8 Compression resistance
- 2.2.9 Density
- 2.2.10 Acoustic performance

The relevant standards, guidelines and project specifications are explained in 2.1. The following text outlines the most important product properties of mineral wool insulation products for insulation of technical installations.

2.2.1 Fire behaviour

a) Introduction

The fire load in a building or technical installation is increased considerably by flammable/combustible insulation materials. Non-combustible insulation materials such as mineral wool, with a melting point higher than 1000°C, on the other hand, not only have a positive impact on the fire load, but also constitute a certain form of fire protection for the insulation installations.

Often one confuses fire resistance with reaction to fire. Fire resistance indicates how well a building component, for instance, can hold back the fire and prevent it from spreading from one room to another – for a stated period of time. Does it function as a fire shield or not? Fire resistance is an extremely important characteristic. For example, a vessel containing flammable liquids. Serious accidents/explosions can occur if a vessel is not protected against fire from the outside.

Reaction to fire indicates the smoke development and combustibility / flammability if the insulation is exposed to fire.

b) CEN standards

A distinction is generally made between non-combustible and combustible building materials. The insulation materials are exposed to fire. The flammability and smoke development and droplets of melted insulation are observed and rated.

The classification of insulation materials depends on the relevant fire standards. In the second half of the 20th century, almost every country in Europe developed their own national system for fire testing and classification of building materials in particular. The European Community has developed a new set of **CEN standards**. The “Reaction to fire” classes test three properties: spread of fire, smoke intensity and burning droplets.

Spread of Fire

The building components are classified in class A1, A2, B, C, D, E and F. Additional classifications provide information on products tending to produce smoke and burning droplets or particles.

- **Class A1** products are non combustible. They will not cause any sustained flaming in the non combustibility test.
- **Class A2** product must not show any sustained flaming for more than 20 seconds in the non combustibility test. The A2 products have to be tested for fire contribution, smoke intensity and burning droplets.
- **Class B** product flaming must not spread more than 150 mm in 60 seconds, when evaluated by a small flame test. Class B products have to be tested for fire contribution, smoke intensity and burning droplets.
- **Class C** product contributes to flashover after 10 min.
- **Class D** product contributes to flashover after 2 min.
- **Class E** product for less than 2 minutes.
- **Class F** this class includes products that do not meet the criteria for E and products that are not tested.

Smoke intensity

Smoke intensity is only tested in the classes from A2 to D. There are 3 intensity levels; s1, s2 and s3. Smoke intensity is vital for people trapped in a burning building. The major cause of death in these circumstances is smoke inhalation.

Burning droplets

Burning droplets are also tested on building materials in the classes A2 to E. There are three classes. No droplets (d0). Droplets that burn out in less than 10 seconds (d1) and droplets that burn for more than 10 seconds (d2).

ROCKWOOL products

Due to its nature, mineral wool is non combustible. Therefore all products are classified as class A1.

c) Project specifications

Many industrial plant owners still refer to the "old" local standards or American (ASTM) Standards. Some of the most important examples are stated below.

For projects outside Europe, especially, many plant owners tend to use the American ASTM E84 or the Canadian equivalent UL723. Both standards solely focus on the surface burning characteristics (flame propagation across the surface of insulation materials).

In Germany, the building material classes for insulation materials for technical insulation are classified according to DIN standard 4102-1. A distinction is made between non flammable building materials in class A1 and A2, and flammable building materials in classes B1 to B3.

- A1 non-flammable
- A2 non-flammable
- B1 flame resistant
- B2 normally inflammable
- B3 highly flammable (cannot be used in Germany)

Alongside the implementation of the European product standards for technical insulation, the "European building material classes", the Euroclasses, are also being implemented. In that case, the products are classified in accordance with the standard DIN EN 13501-1 "Fire classification of building products and building elements

– Part 1: Classification using test class data from reaction to fire tests" in combination with the specifications of the European product standard.

Other local (often building) standards may apply occasionally. e.g.:

- NEN 6064: Netherlands
- NFP 92507 (class M0) France
- BS 476: United Kingdom
- BC (International Building Code): USA
- NBCC (National Building Code of Canada)
- NFPA (National Fire Protection Association):
North America
- UL (Underwriters Laboratory)
- FM (Factory Mutual)

Insurance

UL 1709 ("Standard for Rapid Rise Fire Tests of Protection Materials for Structural Steel") is an example of a standard that insurance providers may require in certain environments such as petrochemical facilities, refineries, pulp and paper mills. When working on projects requiring standards such as UL 1709, be aware some standards apply to systems and not the individual material component.

The ROCKWOOL Technical Insulation sales team can advise designers and manufacturers of installations who are faced with such requirements. Many of the ProRox insulation materials are tested and/or certified in accordance with several local and international standards for reaction to fire.

2.2 Product properties & test methods

2.2.2 Thermal conductivity

The heat-insulating effect of insulation materials is specified in terms of the thermal conductivity " λ ". Low thermal conductivity is equivalent to high insulating capability. λ is conveyed in the physical unit W(m.K) (BTU.in/hr-ft².°F).

The thermal conductivity depends on the temperature, the apparent density and the structure of the insulation and is made up of the following parts:

- Thermal conduction of the dormant air in spaces between the fibres
- Thermal radiation
- Thermal conduction through the fibres
- Convection

The fundamental dependencies of these heat transporters upon temperature and apparent density in the case of mineral wool, are clarified in the graphs below. The individual parts cannot be recorded using measurement techniques and together form the thermal conductivity of an insulation material.

Thermal conductivities for technical insulation can be measured according to the test methods below.

Fundamental dependency of the thermal conductivity upon the apparent density at a certain temperature

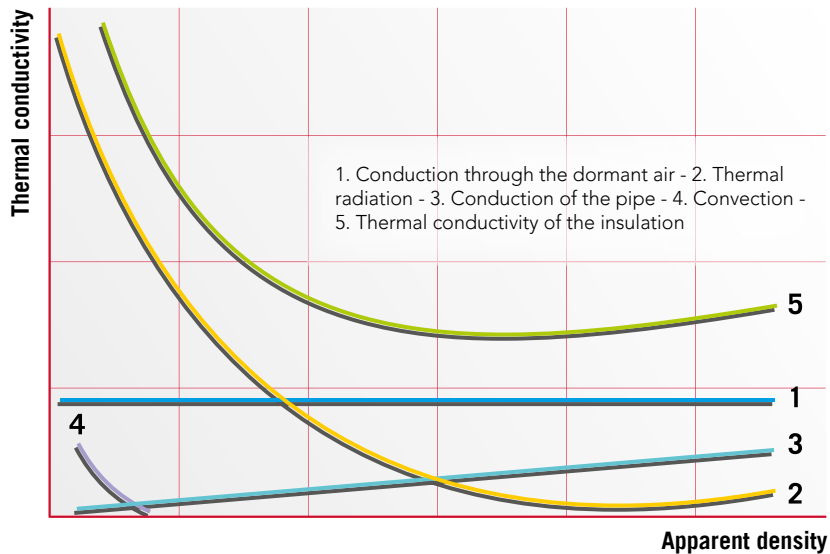

Fundamental dependency of the thermal conductivity upon the temperature for a certain apparent density

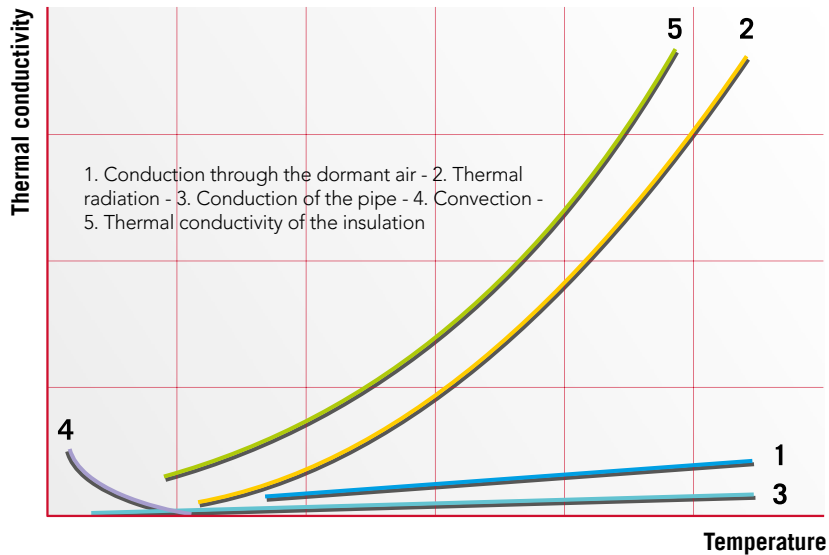

Guarded hot plate apparatus test method

The thermal conductivity of flat products, slabs (board) and wired mats can be measured with the **guarded hot plate apparatus** according to EN12667 or ASTM C177.

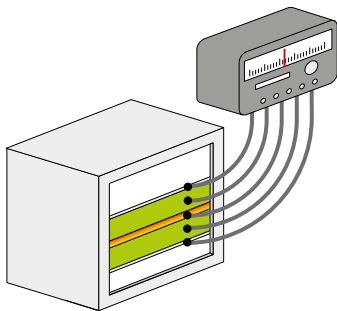

The core components of the apparatus usually consist of two cold-surface units and a guarded hot-surface unit. The insulation material to be measured is sandwiched between these units. The thermal conductivity is calculated at the mean temperature between the hot and the cold side and expressed at the hot face temperature.

Hot pipe apparatus test method

The thermal conductivity of pipe sections and flexible mats can be measured with the hot pipe apparatus according to EN ISO 8497 or ASTM C335.

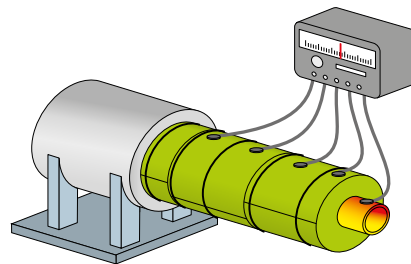

The core consists of a hot pipe with a length of 3 metres (10 feet). The thermal conductivity is calculated at the mean temperature between the hot and cold side and expressed at the mean temperature. The main difference is that the hot pipe apparatus test method includes the seams within the insulation. This explains why the measured values will be higher than the guarded hot plate apparatus test.

2.2 Product properties & test methods

2.2.2 Thermal conductivity

A distinction is drawn between the definition of thermal conductivity.

■ Laboratory thermal conductivity

Thermal conductivity is measured under laboratory conditions with the guarded hot plate apparatus or hot pipe apparatus test method.

■ Nominal (or declared) thermal conductivity

Thermal conductivity specified by the manufacturer, allowing for production related variations in quality and possible ageing, for example caused by gas exchange in closed cell insulation materials.

■ Practical thermal conductivity

Declared thermal conductivity including the influence of joints, design uncertainties, temperature differences, convection, changes in density, moisture absorption and ageing. These effects are taken into consideration using supplementary factors.

■ Operational thermal conductivity

Practical thermal conductivity, whereby the supplementary values for insulation related bridges, such as bearing and support structures are included in the value.

2.2.3 Maximum service temperature

The temperature at which an insulation material is used should be within the temperature range specified for the material, in order to provide satisfactory long-term service under conditions of use.

This temperature is defined as maximum service temperature. The following factors should be considered when selecting insulation materials to be used at elevated operating temperatures.

- Ability to withstand loads and vibrations
- Loss of compression strength after heating
- Linear shrinkage after heating
- Change in thickness after heating and loading
- Internal self-heating (exothermic reaction or punking) phenomena
- Type of finishing of the insulation
- Support structures for the insulation
- Support structures for the cladding

Important note

The maximum service temperature of insulation materials can be tested in accordance with the test methods: EN 14706 and -7 (replaces AGI Q 132), ASTM C411 or BS2972. Each test standard has a different test method and its own criteria. ASTM C411 and BS2972 can be used to determine the maximum operating temperature at which an insulation material can be used, without its insulating capacity deteriorating. EN 14706 and -7 are used to classify insulation materials according to their behaviour at high temperatures based upon time-load exposure. Due to the effect of load during testing, the measure maximum service temperature in accordance with EN 14706 and -7 is lower than the other standards and therefore tends to reflect a more practical temperature limit for design performance.

ASTM C411

ASTM C411 is the standard test method for hot-surface performance of high-temperature thermal insulation.

This standard covers the determination of the performance of mats (wraps), slabs (boards) and pipe sections when exposed to simulated hot-surface application conditions. mats (wraps) and slabs (boards) are tested with the heating plate or pipe apparatus. The heating plate or pipe is uniformly heated to the declared maximum service temperature. Products are exposed to one sided heating.

ASTM C411 places no specific demands on the product performance after heating. Only the following results must be reported.

- Extent of cracking, other visible changes
- Any evidence of flaming, glowing, smouldering, smoking, etc.
- Decrease in thickness, warpage, delamination
- Sagging pipe (pipe insulation)

BS 2972

This standard specifies test methods for the various properties of inorganic thermal insulation materials. Section six "heat stability of this standard" is designed to determine the performance of insulation materials when exposed to heating for 24 hours in an oven or furnace at the designed temperature.

BS 2972 places no specific demands on the product performance after heating. Only the following results must be reported:

- Average percentage change of length, width, thickness and volume of specimens;
- Percentage change of mass of the specimens before and after the test
- Change in compression strength of the specimens before and after the test.

According to BS 3958 "standard specification for thermal insulation materials", the insulation material shall maintain its general form and shall not suffer visible deterioration of fibrous structure when heated to the maximum service temperature.

EN14706 (and EN 14707)

The maximum service temperature replaces the term classification temperature, which was still the customary term in the AGI G 132 of 1996. It is recorded in the laboratory under steady conditions, and takes into account the delivery form. The maximum service temperature for flat products is determined according to the EN 14706 standard and is determined according to the EN 14707 for pipe sections. During the test, the sample insulation material is loaded with 500 Pa pressure, which is equal to a load of approximately 0,5 kN/m² (10.4 PSF).

The sample is then heated on one side at a heating rate of 5 K/min (9°F/min), until the target maximum service temperature is reached.

The temperature is then maintained for 72 hours, before the insulation is allowed to cool down naturally to the ambient temperature. The deformation of the insulation is measured throughout the entire procedure. The deformation is not permitted to exceed 5 % throughout the entire testing process.

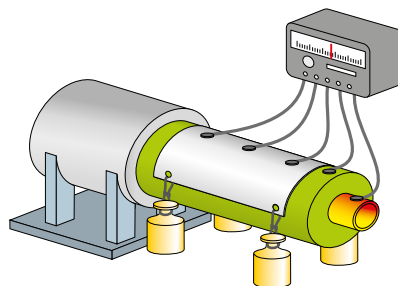
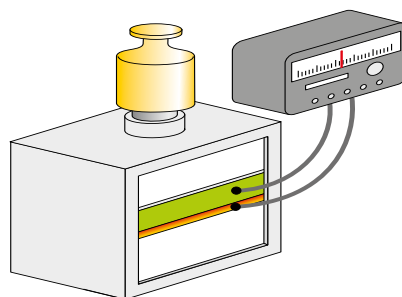

2.2 Product properties & test methods

2.2.3 Maximum service temperature

Application of maximum service temperature

The practical application of the test methods varies per country and plant owner. In case of special conditions, where the insulation is permanently exposed to high dynamic loads and temperatures (e.g. Power Plants), which cannot be included within the measurements, a considered insulation selection is required. This can be done based on expert judgement or by using the reduction factors (f_a) as defined in the German Standard AGI Q101 "Insulation works on power plant components". The calculated service temperature is generally below the maximum

service temperature. When selecting a suitable insulation material in terms of the maximum service temperature, the external influences affecting the insulation system must be considered, for example:

- Static loads (e.g. cladding)
- Dynamic loads (e.g. oscillations)
- Type of construction (with or without a spacer).

The table shown on the following page, showing general reduction ratios f_a for determining the working temperature, is taken from AGI Q101. In this respect, the maximum service temperature should be multiplied by f_a .

Reduction ratio (f_a) for determining the working temperature

Reduction ratio (f_a)	Maximum service temperature		With spacer and support construction	Without spacer and support construction	With spacer and support construction + air space
	(°F)	(°C)			
Pipes ≤ NPS 20 (DN 500)	752	400	1.0	0.9	0.9
	1076	580	0.9	0.9	0.9
	1310	710	0.9	0.8	0.8
Pipes ≥ NPS 20 (DN 500)	752	400	0.9	0.8	0.9
	1076	580	0.9	0.8	0.9
	1310	710	0.9	0.8	0.9
Flue gas ducts, hot air ducts, steel chimneys, vessels, gas turbine ducts	752	400	0.9	0.8	0.9
	1076	580	0.9	0.8	0.9
	1310	710	0.9	0.8	0.8
Boiler walls			0.8		
Within range of boiler roof			0.9		
Dead spaces			0.8		

2.2.4 Water leachable chloride content

The corrosion resistance of steel is increased by the addition of alloying elements such as chromium, nickel and molybdenum. Since this alloying results in a so-called austenitic (face-centred cubic) atomic structure, these types of steel are also called austenitic steels. Despite their generally high resistance to corrosion, these steels tend to exhibit stress corrosion under certain conditions. Three boundary conditions must all be fulfilled in order for stress corrosion cracking to occur:

- The material must be susceptible to stress corrosion.
- Tensile stresses must be present in the component (for example, as a result of thermal elongations).
- There must be a specific attacking agent.

These specific attacking agents include, for example, chloride ions. An insulation material with an extremely low quantity of water-leachable chlorides must therefore be used to insulate objects made from austenitic stainless steel.

For this application, only those insulation materials that are manufactured with a low water leachable chloride content may be used. The classification criteria will depend on the used standard. In general, a distinction can be made between American ASTM standards and European EN standards.

AS-Quality (AGI Q135 – EN 13468)

The following acceptance criteria apply for insulation materials of AS-Quality. The average of six test samples must exhibit a water leachable chloride content of ≤ 10 mg/kg (≤ 10 ppm).

The maximum value of individual measurements must not exceed 12 mg/kg (≤ 12 ppm).

ASTM C871

“Standard Test Methods for Chemical Analysis of Thermal Insulation Materials for Leachable Chloride, Fluoride, Silicate, and Sodium Ions”. This standard covers the laboratory procedures for the determination of the mentioned ions which accelerate stress corrosion of stainless steel. If the results of the chemical analysis for the leachable ions chloride, sodium and silicate fall in the acceptable area of the graph in ASTM C795 and also pass ASTM C692, the insulation material should not cause stress corrosion cracking.

ASTM C692

“Standard Test Method for Evaluating the Influence of Thermal Insulations on External Stress Corrosion Cracking Tendency of Austenitic Stainless Steel”. This standard covers the procedures for the laboratory evaluation of thermal insulation materials that may actively contribute to external stress corrosion cracking (ESCC) of austenitic stainless steel due to soluble chlorides within the insulation. This corrosion test consists of using specimens of insulation to conduct distilled or deionized water by wicking or dripping to an outside surface, through the insulation, to a hot inner surface of stressed stainless steel for a period of 28 days. If leachable chlorides are present, they will concentrate on the hot surface by evaporation. At the conclusion of the 28-day test period, the stainless steel coupons are removed, cleaned and inspected for stress corrosion cracks. To pass the test no cracks may be found on the surface of the coupons.

2.2 Product properties & test methods

2.2.4 Water leachable chloride content

ASTM C795

“Standard Specification for Thermal Insulation for Use in Contact with Austenitic Stainless Steel”. This specification covers non-metallic thermal insulation for use in contact with austenitic stainless steel piping and equipment. In addition to meeting the requirements of this standard, the insulation materials must pass the preproduction test requirements of ASTM C692, for stress corrosion effects on austenitic stainless steel, and the confirming quality control, chemical requirements when tested according to ASTM C871. ASTM C795 shows the results of ASTM C871 in a graph to illustrate a range of acceptable chloride concentrations in conjunction with sodium plus silicate concentrations (see graph illustration below).

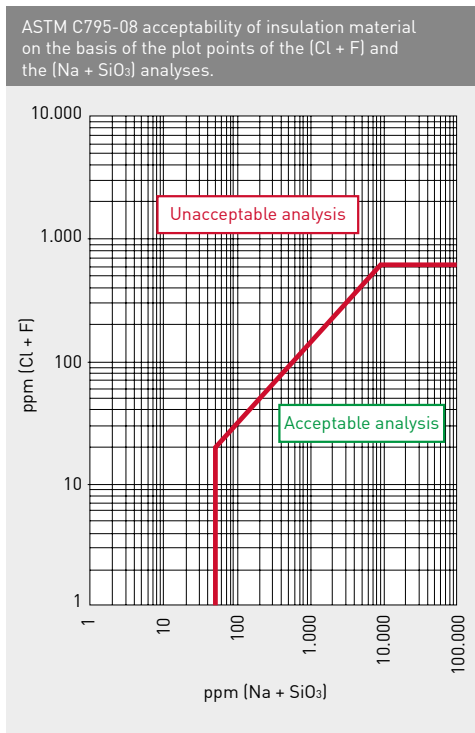

2.2.5 Water repellency

The thermal conductivity and therefore the insulating capacity of mineral wool insulation materials are considerably impaired by the penetration of moisture into the material. Wet insulation material can also contribute to corrosion. Therefore, insulation materials must be protected against moisture during storage, construction and after being fitted. To protect the material against the ingress of moisture, mineral wool insulation materials are offered with a hydrophobic treatment.

Hydrophobic treatment makes it difficult for water to penetrate into the insulation and repels water affecting the insulation from the outside. During the mineral wool manufacturing process, hydrophobic oil, which surrounds each fibre like a protective film, is added. This provides effective protection against moisture penetration across the entire insulation thickness. Hydrophobic treatment does not affect the water vapour diffusion transmission. The effectiveness of the hydrophobic treatment is temporary and depends on the level of moisture. It decreases when exposed to high temperatures. The primary objective of the hydrophobic treatment is to protect the insulation from short bursts of rainfall during installation, for example. In principle, even mineral wool insulation that has been hydrophobically treated must be protected against the ingress of moisture during transport, storage and application.

The water repellency of mineral wool insulation can be tested in accordance with several standards.

EN 1609 & EN 13472 Partial immersion

Tested in accordance with two mineral wool standards, i.e. the EN 1609 standard for slabs (board) and the EN 13472 standard for pipe insulating products. The maximum permissible water absorption in these testing procedures must not exceed 1 kg/m^2 (0.205 lb/ft^2). ProRox insulation products are hydrophobically treated and therefore fulfill these requirements.

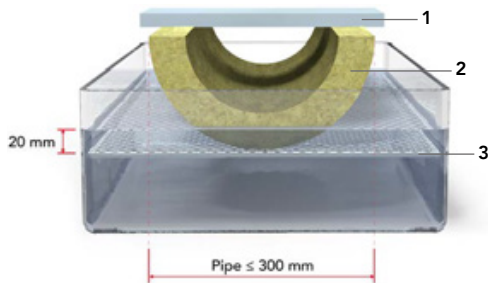

1. A load holding the test sample in a fixed position -
2. Test sample -
3. Stainless steel mesh

BS 2972 Section 12 Total Immersion

This part of the standard covers the determination of the amount of water absorption by mineral fibre insulation. The test sample is 150 mm (6 inch) square and at least 25 mm (1 inch) thick and immersed horizontally with the upper surface approximately 25 mm (1 inch) below the surface of tap water. After the immersion period, the sample must be drained for 5 minutes. The water absorption is calculated using the weight difference before and after testing and the increase is expressed in $\text{kg of water per m}^3$ (b/ft^3).

BS 2972 Section 12 Partial Immersion

This part of standard covers the determination of the amount of water absorption by mineral fibre insulation. The test sample size is 150 mm (6 inch) square and at least 25 mm (1 inch) thick and immersed 6 mm ($1/4 \text{ inch}$) below the surface of tap water for 48 hours. After the immersion period the sample must be drained for 5 minutes. The water absorption is calculated using the weight difference before and after testing and is expressed in kilograms per square metre (lb/ft^2).

Note

British Petroleum places specific demands on the water repellency of mineral wool products. In accordance with the BP172 standard, the samples are heated for 24 hours at 250°C (480°F). The water repellency is tested afterwards in accordance with BS 2972 Section 12 Partial Immersion. Special water repellent grade (WRG) products are available on request. The WR-Tech technology is a further development of the WRG technology used to satisfy the BP RP 52-1 standard. ROCKWOOL combine the heat aging requirement (24 hours at 250°C) from the BP standard, with the more widely accepted test method for water repellency (EN 13472).

ASTM C1763

“Standard Test Method for Water Absorption by Immersion of Thermal Insulation Materials”

This test method determines the amount of water retained (excluding surface water) by test specimens of thermal insulation after these materials have been fully immersed in liquid water for a prescribed time interval under isothermal conditions. This test is typically for flat specimens, but ROCKWOOL Technical Insulation also adopts

2.2 Product properties & test methods

2.2.5 Water repellency

this method for testing their pipe sections. Test specimens are conditioned and then immersed in water for a set amount of time. The amount of water absorbed is determined by the weight increase before and after testing and is expressed in weight percentage or volume percentage.

ASTM C1104 / 1104M

“Standard Test Method for Determining the Water Vapor Sorption of Unfaced Mineral Fiber Insulation”.

This standard covers the determination of the amount of water vapor sorbed by mineral fibre insulation exposed to a high-humidity atmosphere. The test samples are first dried in an oven and then transferred to an environmental chamber maintained at 49°C (120°F) and 95 % relative humidity for 96 hours. The water vapor sorption is calculated using the weight difference before and after testing and is expressed in weight percentage or volume percentage.



Caution with regard to paint shops

When using hydrophobically treated insulation materials in spraying plants, also ensure that the hydrophobic oil does not have any negative impact – e.g. by means of paint wetting impairment substances such as silicon oils – on the coating process. ProRox mandrel wound pipe section with WR-Tech are hydrophobically treated without silicon oils and therefore also fulfil the guidelines of the automotive industry, such as VW-Test 3.10.7. They may be used in paint shops.

2.2.6 Water vapour transmission

With installations constructed outdoors, the possibility of moisture penetrating the insulation system or being “built in” can never be ruled out. Therefore, it is important that insulation exhibits a high degree of water vapour permeability, which allows the water to escape from the installation once it has been started up through diffusion or evaporation processes. This will prevent a negative impact on the insulation properties.

2.2.7 Air flow resistance

The resistance that an insulation material offers against the flow of air is referred to as air flow resistance. It depends on the apparent density, the fibre dimensions, the fibre orientation and the proportion of non-fibrous elements. It determines the level of convection in the insulation and its acoustic-technical properties. The air flow resistance is expressed in terms of (mks rays/m) Pa s/m² and describes the relationship between the pressure difference and flow rate in an insulation material of one metre thickness (1/3 ft).

One of the factors that influences convection in an insulation material is its flow resistance. This is important when insulation materials adjoin air spaces, such as finned walls in boilers, and there are no airtight roofs or intermediate layers (foils).

When such thermal insulation materials are constructed vertically, the longitudinal flow resistance should therefore measure at least 50 kPa s/m² in accordance with EN 29053.

2.2.8 Compression resistance

The resistance that an insulation system offers to external mechanical loads (wind loads, equipment, people, cladding loads) is influenced by factors including the pressure resistance of the insulation.

The compressive stress of mineral wool is preferably specified at 10 % compression. The compressive strength is the ratio of the strength under a predetermined compression to the loaded surface of the test sample,

as identified during a compression test in accordance with EN 826 or in accordance with ASTM C165 "Standard Test Method for Measuring Compressive Properties of Thermal Insulation".

2.2.9 Density

The density of mineral wool products is the amount of fibres per cubic metre. Special care should be taken when comparing only the densities of insulation products. Density influences several product properties. It is however not a product property itself. A common assumption is that the higher the density, the more the compression resistance, maximum service temperature and thermal conductivity will improve. This is only correct to a certain extent. A few examples:

Binder content

During the manufacture of mineral wool products, a so called binder is added to glue/form the fibres into the desired shape. The binder content positively influences the compression strength, but due to its organic compounds has a negative effect on the maximum service temperature and fire resistance.

Thermal conductivity

For high temperatures it is often better to use high density (less radiation) mineral wool insulation. At temperatures below 150°C (300°F), the conduction throughout the fibres will be more dominant, so using a lower density product is preferable.

Fibre structure

The (vertical, horizontal...) orientation of the fibres influences the longitudinal air flow resistance, compressive strength, and thermal conductivity. Generally, the more "vertical" fibres, the better the compressive strength and the higher the thermal conductivity will be.

Non-fibrous particles

Non-fibrous particles or shot content in mineral wool products have a negative influence on the thermal conductivity. For example, a mineral wool

product with a density of 100 kg/m³ (6.2 lb/ft³) and 15 % shot content, (tested in accordance with ASTM C 612 on a meshed netting (150 mm, 100 mesh)), would have the same thermal conductivity as a mineral wool product with a density of 140 kg/m³ and (8.7 lb/ft³) 40 % shot content.

ProRox insulation are high quality, high performing products that exceed ASTM C612 stone wool requirements. ASTM C612-14 states that shot should not exceed 25% and allowable shot content has been reduced over time in version revisions. The less shot in insulation the greater the Nominal density. It is important to determine if specified density is referring to nominal or actual when reviewing insulation specifications. ProRox products achieve excellent thermal conductivity and fire resistance performance, even at low densities.

Density: Nominal vs Actual

Density as per ASTM C168 is defined as "the mass per unit volume of material". Density is not a performance criteria but is commonly referred to when specifying insulation. Density is sometimes specified as Actual or Nominal. Actual density (sometimes referred to as Delivered density) is the true density of the insulation and Nominal Density is the effective density of the insulation relative to a historic benchmark where the insulation contained 40% non-fibrous content also known as shot (ASTM C612-99).

Insulation selection

Every mineral wool insulation product has specific characteristics. Insulation should therefore be based on the actual product performance, not on the density.

A simple way to relate

Nominal density relates to actual density in the same way equivalent wattage of a fluorescent light bulb relates to an incandescent light bulb. E.g. A fluorescent light bulb with 13 watts (actual) performs the same as 100 watts incandescent.

2.2 Product properties & test methods

2.2.10 Acoustic performance

ISO 15565 standard is setting classes for acoustic pipework insulation systems. Insulation systems are classified by their insertion loss performance and the diameter of pipe onto which they are applied. ISO 15665 is valid for pipes up to 1000 mm in diameter. It is not applicable to the acoustic insulation of rectangular ducting and vessels or machinery.

- The standard allows noise control engineers to select the correct insulation system during the design stage in order to ensure that specified noise targets are met.
- ISO 15665 is largely adopted by the major operators in oil and gas business.
- Similar requirements are laid down in NORSOK standard R-004 class 6,7 & 8, CINI 9.2.02 and ASTM E 1222.

Minimum insertion loss required for each class

Class	Range of nominal diameter <i>D</i> mm	Nominal Pipe Size NPS inch	Octave band centre frequency, Hz						
			125	250	500	1000	2000	4000	8000
			Minimum insertion loss, dB						
A1	$D < 300$	NPS < 12	-4	-4	2	9	16	22	29
A2	$300 \leq D < 650$	$12 \leq \text{NPS} < 26$	-4	-4	2	9	16	22	29
A3	$650 \leq D < 1000$	$26 \leq \text{NPS} < 40$	-4	2	7	13	19	24	30
B1	$D < 300$	NPS < 12	-9	-3	3	11	19	27	35
B2	$300 \leq D < 650$	$12 \leq \text{NPS} < 26$	-9	-3	6	15	24	33	42
B3	$650 \leq D < 1000$	$26 \leq \text{NPS} < 40$	-7	2	11	20	29	36	42
C1	$D < 300$	NPS < 12	-5	-1	11	23	34	38	42
C2	$300 \leq D < 650$	$12 \leq \text{NPS} < 26$	-7	4	14	24	34	38	42
C3	$650 \leq D < 1000$	$26 \leq \text{NPS} < 40$	1	9	17	26	34	38	42

In order to conform to a given class, the insertion loss of all seven octave bands shall exceed or be equal to the levels specified. An acoustic insulation that does not fully satisfy above requirement shall be designated as "unclassified".

2. Theory

2.3 Bases for thermal calculations

The following section outlines a number of theoretical bases for heat transfer and basic approaches to thermo-technical calculations. Detailed calculation processes are outlined in the VDI 2055, and the EN 12241 standards, as well as in various international standards, such as ASTM C 680 and BS 5970. The calculation bases are similar in all the standards. In Europe, the VDI 2055 is the most widely used and accepted calculation basis.

The calculation of multiple-layer insulation constructions is to some extent quite complex,

as iterative calculation processes need to be carried out. The procedures outlined below are therefore only suitable to obtain an approximate calculation of insulation constructions.

The thermo-technical engineering program 'Rockassist' offered by ROCKWOOL Technical Insulation can be used for detailed calculations.

For technical assistance and the most up-to-date data for heat transfer and thermal modelling contact the ROCKWOOL Technical Services Team.

Rockassist thermo-technical calculation program



Go and register online for our free Rockassist calculation tool

EXPERT TOOL

rti.rockwool.com

Rockassist is available on smartphone and tablet

2. Theory

2.3.1 Heat transfer

During a thermal transfer, thermal energy is transported as a result of a temperature drop. Thermal transfers can occur through conduction, convection or radiation.

- **Thermal conduction** is the transport of heat from one molecule to another, as a result of a drop in temperature. In solid substances, the average distance between the individual molecules remains the same. In liquids and gases however, the distance changes.
- In the case of **convection**, the thermal transfer takes place in liquids and gases through flow processes. A distinction is drawn between free convection, in which the movement occurs as a result of variations in density, and forced convection, in which the flow is generated by external influences such as the wind and by blowers.
- Thermal transfer through **radiation** takes place as a result of the exchange of electromagnetic radiation between two body surfaces, which have different temperatures and are separated by radiation permeable media, such as air.

a) Heat transfer – European basis and terms

Heat quantity Q

The heat quantity is the thermal energy that is supplied to or dissipates from a body. The unit used to designate the heat quantity is J.

Heat flow Q̇

The heat flow Q̇ is the heat quantity flowing in a body or being transferred between two bodies per time unit. The unit used to designate the heat flow is W (1W = 1J/s).

Heat flow density q

The heat flow density q is the heat flow being applied to the unit of the surface that the heat is flowing through.

The unit is expressed in W/m² for surfaces or in W/m for pipes, for example. In the field of insulation technology, the heat flow density refers to the surface of the insulation system.

Thermal conductivity λ

The heat-insulating effect of insulation materials is described in terms of the thermal conductivity λ. It indicates the quantity of heat "Q" that, in "t" amount of time and at a temperature difference of "ΔT", flows across the thickness "s" through the surface area "A".

$$\lambda = \frac{Q \cdot s}{A \cdot t \cdot \Delta T} \left[\frac{\text{J} \cdot \text{m}}{\text{m}^2 \cdot \text{s} \cdot \text{K}} = \frac{\text{J}}{\text{m} \cdot \text{s} \cdot \text{K}} = \frac{\text{W}}{\text{m} \cdot \text{K}} \right]$$

The unit of the thermal conductivity λ is expressed in terms of J/(m s K) or W/(m K).

Thermal conductance Λ

The coefficient of thermal conductance "Λ" indicates, for a given layer, the heat flow density flowing vertically between the surfaces over an area of 1 m² at a temperature difference of 1 K. The unit used to express the coefficients of thermal conductance is W/(m² K).

$$\Lambda = \frac{\text{Thermal conductivity}}{\text{Applied insulation thickness}} = \frac{\lambda}{s} \left[\frac{\text{W}}{\text{m}^2 \cdot \text{K}} \right]$$

Thermal resistance R

The thermal resistance "R" is the reciprocal of the coefficients of thermal resistance. The unit used to express the thermal resistance is (m² K)/W.

$$R = \frac{\text{Applied insulation thickness}}{\text{Thermal conductivity}} = \frac{s}{\lambda} \left[\frac{\text{m}^2 \cdot \text{K}}{\text{W}} \right] \text{ for walls}$$

$$R_{\text{pipe}} = \frac{\ln\left(\frac{d_a}{d_i}\right)}{2 \cdot \pi \cdot \lambda} \left[\frac{\text{m} \cdot \text{K}}{\text{W}} \right] \text{ for pipe insulation}$$

Surface coefficient of heat transfer α

The surface coefficient of heat transfer "α" gives the heat flow density circulating at the surface of a body in a medium or vice versa, when the temperature difference between the body and the liquid or gaseous medium amounts to 1 K. The unit used to express surface coefficients of heat transfer is W/(m²K).

Heat transfer resistance $1/\alpha$

The heat transfer resistance “ $1/\alpha$ ” is the reciprocal of the surface coefficients of heat transfer. The unit used to express the heat transfer resistance is $(\text{m}^2\text{K})/\text{W}$.

Coefficient of thermal transmittance k

The coefficient of thermal transmittance “ k ” indicates the heat flow density “ q ” circulating through a body, when there is a temperature difference of 1 K between the two media, which are separated by the body. The coefficient of thermal transmittance includes the thermal resistance and heat transfer components. The unit used to express coefficients of thermal transmittance is $\text{W}/(\text{m}^2 \text{K})$.

Thermal transmission resistance $1/k$

The thermal transmission resistance is the reciprocal of the coefficients of thermal transmittance. The unit used to express thermal transmission resistance is $(\text{m}^2\text{K})/\text{W}$.

$\frac{1}{k} = \text{Heat transfer resistance}_{\text{inside}} + \text{Thermal resistance} + \text{Heat transfer resistance}_{\text{outside}}$

$$\frac{1}{k_w} = \frac{1}{\alpha_i} + R_w + \frac{1}{\alpha_a} \quad \left[\frac{\text{m}^2 \cdot \text{K}}{\text{W}} \right] \quad \text{for a wall}$$

$$\frac{1}{k_R} = \frac{1}{d_i \cdot \pi \cdot \alpha_i} + R_R + \frac{1}{d_a \cdot \pi \cdot \alpha_a} \quad \left[\frac{\text{m} \cdot \text{K}}{\text{W}} \right]$$

for pipe insulation

Calculation bases

The heat flow density through a flat wall constructed of multiple layers is calculated as follows:

$$q = k \cdot (\vartheta_M - \vartheta_L)$$

$$\frac{1}{k} = \frac{1}{\alpha_i} + \frac{s_1}{\lambda_1} + \frac{s_2}{\lambda_2} + \dots + \frac{s_n}{\lambda_n} + \frac{1}{\alpha_a}$$

$$q = \frac{(\vartheta_M - \vartheta_L)}{\frac{1}{\alpha_i} + \frac{s_1}{\lambda_1} + \frac{s_2}{\lambda_2} + \dots + \frac{s_n}{\lambda_n} + \frac{1}{\alpha_a}} \quad \left[\frac{\text{W}}{\text{m}^2} \right]$$

The following symbols are used in this calculation:

q	Heat flow density	W/m^2
ϑ_M	Temperature of the medium in	$^{\circ}\text{C}$
ϑ_L	Ambient temperature in	$^{\circ}\text{C}$
α_i	Surface coefficient of heat transfer inside	$\text{W}/(\text{m}^2 \text{K})$
α_a	Surface coefficient of heat transfer outside	$\text{W}/(\text{m}^2 \text{K})$
$s_1 \dots s_n$	Thickness of the individual layers of insulation	m
$\lambda_1 \dots \lambda_n$	Thermal conductivity of the individual insulation layers	$\text{W}/(\text{m K})$
k	Coefficient of thermal transmittance	$\text{W}/(\text{m}^2 \text{K})$

With multiple-layer hollow cylinder (pipe insulation), the heat flow density is calculated as follows:

$$q_R = k_R \cdot (\vartheta_M - \vartheta_L)$$

$$\frac{1}{k_R} = \frac{1}{d_i \cdot \pi \cdot \alpha_i} + \frac{\ln\left(\frac{d_2}{d_1}\right)}{2 \cdot \pi \cdot \lambda_1} + \frac{\ln\left(\frac{d_3}{d_2}\right)}{2 \cdot \pi \cdot \lambda_2} + \dots + \frac{\ln\left(\frac{d_a}{d_n}\right)}{2 \cdot \pi \cdot \lambda_n} + \frac{1}{d_a \cdot \pi \cdot \alpha_a} \quad \left[\frac{\text{m} \cdot \text{K}}{\text{W}} \right]$$

$$q_R = \frac{\pi \cdot (\vartheta_M - \vartheta_L)}{\frac{1}{d_i \cdot \alpha_i} + \frac{\ln\left(\frac{d_2}{d_1}\right)}{2 \cdot \lambda_1} + \frac{\ln\left(\frac{d_3}{d_2}\right)}{2 \cdot \lambda_2} + \dots + \frac{\ln\left(\frac{d_a}{d_n}\right)}{2 \cdot \lambda_n} + \frac{1}{d_a \cdot \alpha_a}} \quad \left[\frac{\text{W}}{\text{m}} \right]$$

The following symbols are used in this calculation:

q_R	Heat flow density per m pipe	W/m
ϑ_M	Temperature of the medium in	$^{\circ}\text{C}$
ϑ_L	Ambient temperature in	$^{\circ}\text{C}$
d_i	External diameter of pipe	m
d_a	External diameter of insulated pipe	m
α_i	Surface coefficient of heat transfer inside	$\text{W}/(\text{m}^2 \text{K})$
α_a	Surface coefficient of heat transfer outside	$\text{W}/(\text{m}^2 \text{K})$
$\lambda_1 \dots \lambda_n$	Thermal conductivity of the individual insulation layers	$\text{W}/(\text{m K})$
k	Coefficient of thermal transmittance	$\text{W}/(\text{m}^2 \text{K})$
$s_1 \dots s_n$	Thickness of the individual layers of insulation	m

2.3 Bases for thermal calculations

2.3.1 Heat transfer

Hint

When performing thermo-technical calculations in insulation technology, the internal heat transfer does not generally need to be considered. This simplification is based on the assumption that the medium is the same temperature as the interior of the pipe. The following terms may therefore be omitted from the calculations shown above:

$\frac{1}{\alpha_i}$ remove from the denominator in the equation for the wall

$\frac{1}{d_i \cdot \alpha_i}$ remove from the denominator in the equation for pipe insulation

The surface temperatures ϑ_0 can be calculated as follows:

$$\vartheta_0 = \frac{k_w}{\alpha_a} \cdot (\vartheta_M - \vartheta_L) + \vartheta_L \quad [\text{°C}] \quad \text{for walls}$$

$$\vartheta_0 = \frac{(\vartheta_M - \vartheta_L)}{\alpha_a \cdot \left(\frac{1}{\alpha_i} + \frac{S_1}{\lambda_1} + \frac{S_2}{\lambda_2} + \dots + \frac{S_n}{\lambda_n} + \frac{1}{\alpha_a} \right)} + \vartheta_L \quad [\text{°C}]$$

$$\vartheta_0 = \frac{k_R}{\pi \cdot d_a \cdot \alpha_a} \cdot (\vartheta_M - \vartheta_L) + \vartheta_L \quad \text{°C} \quad \text{for pipe insulation products}$$

$$\vartheta_0 = \frac{(\vartheta_M - \vartheta_L)}{d_a \cdot \alpha_a \cdot \left(\frac{1}{d_i \cdot \alpha_i} + \frac{\ln\left(\frac{d_2}{d_1}\right)}{2 \cdot \lambda_1} + \frac{\ln\left(\frac{d_3}{d_2}\right)}{2 \cdot \lambda_2} + \dots + \frac{\ln\left(\frac{d_n}{d_{n-1}}\right)}{2 \cdot \lambda_n} + \frac{1}{d_a \cdot \alpha_a} \right)} + \vartheta_L \quad [\text{°C}]$$

Hint

The internal heat transfer can once again be disregarded (see hint in previous column).

The characteristic of emitting heat from a surface (e.g. the external cladding) into the surrounding medium, which is usually air, is described by means of the external surface coefficient of heat transfer " α_a ". The surface coefficient of heat transfer is made up of the rate of convection and radiation.

$$\alpha_a = \alpha_k + \alpha_r$$

The following symbols used in this calculation:

α_k the rate of convection

α_r the rate of radiation

The rate of convection consists only of free convection (air movement due solely to variations in density as a result of temperature), forced convection (blowers, wind) or of a mixture of free and forced convection. The convection also depends on the geometry of the building component.

The rate of radiation depends on factors such as the material of the cladding (emission ratio ϵ), the surface temperature and the orientation of the object in relation to other components.

The calculation procedures are explained in the VDI 2055 and EN 12241 standards. A detailed description will not be given at this point.

Use the following procedure to obtain an approximate estimate of the external surface coefficients of heat transfer α_a . It applies in respect of the following boundary conditions:

■ Applicable only for free convection

■ $\Delta\vartheta = \vartheta_0 - \vartheta_L \leq 60\text{K}$

■ $\vartheta_m = 0,5 \cdot (\vartheta_0 - \vartheta_L) \approx 40^\circ\text{C}$

■ $d_a \approx 0,5\text{m}$

The following applies for horizontal pipes:

$$\alpha_a = A + 0,05 \cdot \Delta\vartheta \quad \left[\frac{\text{W}}{\text{m}^2 \cdot \text{K}} \right]$$

The following applies for vertical pipes and walls:

$$\alpha_a = B + 0,09 \cdot \Delta\vartheta \quad \left[\frac{\text{W}}{\text{m}^2 \cdot \text{K}} \right]$$

ϑ_0 is the surface temperature of the cladding
 ϑ_L is the ambient temperature

The values for A and B have been compiled for a number of materials and surfaces in the table shown below.

Surface	A	B
Aluminium, rolled	2.5	2.7
Aluminium, oxidised	3.1	3.3
Galvanised sheet, bright	4.0	4.2
Galvanised sheet, tarnished	5.3	5.5
Austenitic steel	3.2	3.4
Alu-Zinc – sheet	3.4	3.6
Non-metallic surface	8.5	8.7

Supplementary values $\Delta\lambda$. Thermal bridges

In addition to the insulation thickness, the total heat loss from insulated objects depends on thermal bridges, which have a negative impact on the insulation system. A distinction is drawn between thermal bridges caused by the insulation and thermal bridges caused by the installation. Thermal bridges caused by the insulation system include support constructions and spacers, whereas thermal bridges caused by the installation include pipe hangings and supports, flanges and brackets.

Allowances are made for these thermal bridges in the form of supplementary factors that are multiplied by the surface coefficients of heat transfer.

Table 3 of the VDI 2055 includes relevant supplementary values for thermal bridges caused by the insulation.

The thermo-technical engineering calculation program 'Rockassist' can be used to calculate heat losses from objects whilst allowing for thermal bridges. Please visit the rti.rockwool.com website for consulting the Rockassist program online.

b) Heat transfer – ASTM C168 and C680 - North American basis and terms

Heat (Energy)

Heat is the quantity of thermal energy that is supplied to or dissipates from a body. The unit of heat is BTU (Joule).

Heat flow rate, Q

The heat flow rate, Q, is the quantity of heat transferred to or from a system in unit time. The unit of heat flow is BTU/hr (Watt).

Heat flux, q

Heat flux, q, is the heat flow rate through a surface of unit area perpendicular to the direction of heat flow. The units are expressed in BTU/hr.ft² (W/m²) for surfaces or BTU/hr.ft (W/m) for pipes (referring to the surface of the insulation).

Mean Specific Heat

The quantity of heat required to change the temperature of a unit mass of a substance one degree. The units are expressed as BTU/lb.°F (J/kg.K).

Thermal Capacity (heat capacity)

The quantity of heat required to change the temperature of the body one degree. The unit of heat capacity is BTU/°F (J/K).

Conductivity

Thermal conductivity is a material property defining heat flow through a homogeneous material, "λ" (or "k"). It indicates the heat flow rate "Q" through unit area of material "A" induced by unit temperature gradient "ΔT / L" in a direction perpendicular to that unit area (Heat-Flux per unit temperature difference across a unit thickness of material).

The unit of thermal conductivity is BTU.in/hr.ft².°F (W/m.K).

$$\lambda = \frac{(Q/t)}{A \cdot (\Delta T/L)}$$

2.3 Bases for thermal calculations

2.3.1 Heat transfer

Apparent Thermal Conductivity

A thermal conductivity assigned to a material that exhibits thermal transmission by several modes of heat transfer resulting in property variation with specimen thickness, or surface emittance.

Thermal conductivity and resistivity are normally considered intrinsic or specific properties of materials and, as such, should be independent of thickness. When nonconductive modes of heat transfer are present within the specimen (radiation, free convection) this may not be the case. To indicate the possible presence of this phenomena the modifier "apparent" is used, as in apparent thermal conductivity.

Conductance, C

The conductive heat transfer coefficient, C, (thermal conductance) is the thermal conductivity of a system or a particular thickness under consideration; it is not a material property. Thermal conductance is the heat flow rate per unit area per unit temperature difference across a system or piece of material - the thickness to which the conductance is assigned must be defined. The unit of thermal conductance is BTU/hr.ft².°F (W/m²K)

$$C = \frac{\text{Thermal Conductivity}}{\text{Applied Insulation Thickness}} = \frac{\lambda}{L}$$

Note: Within the ASTM standards and ASHRAE handbooks the term "Conductance" is used both in the strict sense (as defined above in relation to heat transfer by conduction) and in a more general loose sense to refer to the heat transfer coefficient by any, or all, of conduction, convection and radiation (in isolation or combination).

Resistivity

The quantity determined by the temperature difference, at steady state, between two defined parallel surfaces of a homogeneous material of unit thickness that induces a unit heat flow rate through a unit area. Thermal resistivity is the reciprocal of thermal conductivity. Where a

material exhibits thermal transmission by several modes of heat transfer the term "apparent thermal resistivity" is applied. The units of thermal resistivity are hr.ft.°F/BTU or hr.ft².°F/BTU-in (mK/W).

Thermal Diffusivity

The ratio of thermal conductivity of a substance to the product of its density and specific heat. The unit of thermal diffusivity is:

$$\frac{(\text{BTU}/(\text{hr}\cdot\text{ft}\cdot\text{F}))}{(\text{lb}/\text{ft}^3)\cdot(\text{BTU}/\text{lb}\cdot\text{F})} = \frac{\text{ft}^2}{\text{hr}} = (\text{m}^2/\text{s})$$

Heat Transfer Coefficient, u

The proportionality coefficient defining general heat flow in unit time through unit area induced by unit temperature difference between the environments on each side. Heat transfer coefficients can be defined for heat transfer taking place by the mechanisms of conduction, convection or radiation (individually or combined). Note: with the ASTM standards and ASHRAE handbooks the term "conductance", as defined in the strict sense, applies to the conductive heat transfer coefficient, C, but the term "conductance" is also loosely applied to the heat transfer coefficient of any layer with heat transfer by any, or all, of conduction, convection and radiation. When used in this general sense the symbol u_n is used, where the subscript, n, references the particular layer (or layers) under consideration.

Overall Coefficient of heat transfer (U-Factor or Thermal Transmittance), U

The proportionality coefficient defining heat transmission in unit time through unit area of a material or construction and the boundary films, induced by unit temperature difference between the environments on each side. Units are BTU/hr.ft².°F (W/m² K).

Surface Coefficient

Surface Coefficient (surface transfer conductance) is the ratio of the steady-state heat exchange rate (time rate of heat flow per unit area of a particular surface by the combined effects of radiation,

conduction and convection) between a surface and its external surroundings (air or other fluid and other visible surface) to the temperature difference between the surfaces and its surroundings.

The surface coefficient includes the combined effects of radiant, convective and conductive heat transfer, it is defined by:

$$h = h_r + h_c$$

where h_r is the component due to radiation (Radiant Heat Transfer Conductance) and h_c is the component due to convection and conduction (Convective Heat Transfer Conductance). Units are BTU/hr.ft².°F (W/m² K).

Radiant Heat Transfer Conductance

The radiant component of surface transfer conductance, defined by:

$$h_r = \frac{\sigma \epsilon (T_s^4 - T_o^4)}{T_s - T_o}$$

Convective Heat Transfer Conductance (Film Conductance)

The time rate of heat flow from a unit area of a surface to its surroundings, induced by a unit temperature difference between the surface and the environment where the environment is a fluid (liquid or gases). Convective heat transfer conductance is the convective (and conductive) component of surface transfer conductance, h_c ; it does not include radiative component. Film conductance depends on the nature of fluid motion past the surface (laminar or turbulent). Units are BTU/hr.ft².°F (W/m² K).

In general, indoor or outdoor heat transfer coefficient (or surface film coefficient) are denoted by h_i and h_o respectively for the interior and exterior surface.

Emittance, ϵ

The ratio of the radiant flux emitted by a specimen to that emitted by a black body at the same temperature under the same conditions.

Resistance, R

The thermal resistance, R, is the reciprocal of the thermal conductance. The units of thermal resistance are °F.ft².hr/BTU (m²K/W).

$$R = \frac{1}{C}$$

Overall resistance to thermal transfer is sum of the thermal resistance of individual layers, it is the reciprocal of the overall heat transfer coefficient, U.

$$R_{total} = \frac{1}{U} = \frac{\text{Heat Transfer}}{\text{Resistance}_{inside}} + \frac{\text{Heat Transfer}}{\text{Resistance}_{material}} + \frac{\text{Heat Transfer}}{\text{Resistance}_{outside}}$$

$$R_{total} = R_i + R_1 + R_2 + \dots + R_n + R_o$$

$$\frac{1}{U} = \frac{1}{\frac{1}{U_i} + \frac{1}{U_1} + \frac{1}{U_2} + \dots + \frac{1}{U_n} + \frac{1}{U_o}}$$

3

Tables

ProRox®

Industrial
insulation



3. Tables

Table of contents

3.1	Units, conversion factors and tables	142
3.1.1a	Symbols, definitions and units (US Convention)	142
3.1.1b	Symbols, definitions and units (European Convention)	144
3.1.2	Mathematical symbols	145
3.1.3	SI pre-fixes	146
3.1.4	Greek alphabet	146
3.1.5	SI units	147
3.1.6	SI derived units with special names	147
	a) European units	148
	b) US units	149
3.1.7	Compound units derived from SI-units	150
3.1.8	Temperature scales and conversions	151
3.1.9	Conversion degrees Celcius and Fahrenheit	151
3.1.10	Imperial (Anglo-Saxon) units	152
3.1.11	Conversion of energy and heat scales	155
3.1.12	Conversion power scales	155
3.1.13	Conversion of pressure scales	156
3.1.14	Conversion of SI-units into Imperial units, pre-SI units and technical scales	156
3.1.15	Density conversion table	157
3.2	Product properties insulation and cladding materials	158
3.2.1	Insulation materials	158
3.2.2	Cladding materials	158
3.3	Usage tables	163
3.3.1	Construction materials	163
3.3.2	Fluids which are commonly used in process industry	164
3.3.3	Gases which are commonly used in process industry	165
3.3.4	Conversion factors in relation to the heat of combustion	165
3.3.5	Specific enthalpy super heated steam in kJ/kg	166
3.3.6	Density super heated steam kg/m ³	167
3.3.7	Dew point table	168
3.3.8	Climate data	170
3.3.9	Guidelines average velocities in pipe work	177
3.3.10	Pipe diameter	177
3.3.11	Fire curve: ISO and hydrocarbon	179

3. Tables

3.1 Units, conversion factors and tables

3.1.1a Symbols, definitions and units (US Convention)

Symbol	Definition	US Unit	Notes
A	Area	ft ²	
L	Length	ft, in	
σ	Stefan-Boltzman Constant 0.1714 x 10 ⁻⁸	BTU/hr.ft ² .°R ⁴	
ϵ	Emittance	-	
-	Specific heat capacity	BTU/lb.°F	
c_p	Specific heat capacity at constant pressure	BTU/lb.°F	
c_v	specific heat capacity at constant volume	BTU/lb.°F	
-	thermal diffusivity	ft ² /hr	
-	thermal capacity	BTU/°F	
u	Heat transfer coefficient (general)	BTU/hr.ft ² .°F	linear orientation
		BTU/hr.ft.°F	cylindrical orientation
		BTU/hr.°F	spherical orientation
U	Overall Heat Transfer Coefficient (Thermal Transmittance)	BTU/hr.ft ² .°F	Flat Wall
h_c	Film conductance (convective heat transfer coefficient) (convective heat transfer conductance)	BTU/hr.ft ² .°F	Flat Wall
		BTU/hr.ft.°F	Pipe
		BTU/hr.°F	sphere
h_r	Radiant heat transfer conductance	BTU/hr.ft ² .°F	Flat Wall
		BTU/hr.ft.°F	Pipe
		BTU/hr.°F	sphere
h	Surface coefficient of heat transfer (surface transfer conductance)	BTU/hr.ft ² .°F	Flat Wall
		BTU/hr.ft.°F	Pipe
		BTU/hr.°F	sphere
C	Conductance	BTU/hr.ft ² .°F	
k (or λ)	Thermal conductivity	BTU-in/hr.ft ² .°F	(conventional unit)
		BTU/hr.ft.°F	(alternative)
k_a (or λ_a)	Apparent thermal conductivity	BTU-in/hr.ft ² .°F	



Symbol	Definition	US Unit	Notes
R	Thermal resistance	hr.ft ² .°F/BTU	linear orientation
		hr.ft.°F/BTU	cylindrical orientation
		hr.°F/BTU	spherical orientation
r	Thermal resistivity	hr.ft ² .°F/BTU-in	(conventional unit)
		hr.ft.°F/BTU	(alternative)
r _a	Apparent thermal resistivity	hr.ft ² .°F/BTU-in	
-	Heat Energy	BTU	
Q	Heat Flow Rate	BTU/hr	
q	Heat Flux	BTU/hr.ft ²	
T	Temperature	°R or °F	
T _s	Absolute Surface Temperature (Rankine)	°R	
T _o	Absolute surroundings temperature (Rankine)	°R	
i	inner boundary layer	-	subscript
o	outer boundary layer	-	subscript
s	surface	-	subscript
1 ... n	internal layer	-	subscript

3.1 Units, conversion factors and tables

3.1.1b Symbols, definitions and units (European Convention)

Symbol	Definition	Unit
A	Area	m ²
b	Length	m
C ₁₂	Radiation coefficient	W/(m ² · K ⁴)
c	Specific heat capacity	J/(kg · K)
c _p	Specific heat capacity at constant pressure	J/(kg · K)
d	Diameter	m
f	Correction factor	-
H	Height	m
h	Enthalpy	J/kg
k	Heat transfer coefficient	W/(m ² · K), W/K, W/(m · K)
k'	Total heat transfer coefficient	W/(m ² · K), W/K, W/(m · K)
l	Length	m
m	Mass	kg
\dot{m}	Massflow	kg/s, kg/h
n	Operation time	a
P	Pressure	Pa
Q	Heat energy	J
\dot{Q}	Heat flow	W
q	Heat flow density	W/m ² or W/m
R	Thermal resistance	m ² · K/W, m · K/W, K/W
R	Specific heat capacity	J/(kg · K)
s	Insulation thickness	m
t	Time	h or s
T	Temperature (Kelvin)	K
U	Circumference	m
w	Wind speed	m/s
α	Total heat transfer coefficient (incl. cold bridges)	W/(m ² · K)

Symbol	Definition	Unit
α	Linear expansion coefficient	K ⁻¹
Λ	Thermal conductance	W/(m ² · K)
λ	Thermal conductivity	W/(m · K)
ε	Emissivity	-
η	Yield, efficiency	-
ϑ (also t)	Temperature	°C
μ	Water vapor resistance factor	-
μ	Water vapor resistance	-
ρ	Density	kg/m ³
φ	Relative humidity	-
Ξ	Air flow resistance	Pa · s/m ²

3.1.2 Mathematical symbols

Mathematical symbols	
=	equal to
<	less than
≤	less than or equal to
<<	much less than
+	plus
∞	infinity
π	pi \approx 3.14159
\approx	approximately
>	greater than
≥	equal to or greater than
>>	much greater than
Δ	Difference
Σ	Sum
ln	Logarithm base e
log	Logarithm base 10

3.1 Units, conversion factors and tables

3.1.3 SI pre-fixes

Decimal parts and multiples of units are conveyed by means of prefixes and corresponding symbols. Several prefixes cannot be compounded.

Name	Symbol	Conversion factor
Atto	A	10^{-18}
Femto	F	10^{-15}
Piko	P	10^{-12}
Nano	n	10^{-9}
Mikro	μ	10^{-6}
Milli	m	10^{-3}
Centi	c	10^{-2}
Deci	d	10^{-1}
Deca	da	10^1
Hecto	h	10^2
Kilo	k	10^3
Mega	M	10^6
Giga	G	10^9
Tera	T	10^{12}
Peta	P	10^{15}
Exa	E	10^{18}

3.1.4 Greek alphabet

Greek alphabet							
A α	Alpha	H η	Eta	N ν	Nu	T τ	Tau
B β	Beta	Θ θ	Theta	Ξ ξ	Xi	Υ υ	Ypsilon
Γ γ	Gamma	I ι	Iota	O \omicron	Omicron	Φ ϕ	Phi
Δ δ	Delta	K κ	Kappa	Π π	Pi	X χ	Chi
E ϵ	Epsilon	Λ λ	Lambda	P ρ	Rho	Ψ ψ	Psi
Z ζ	Zeta	M μ	Mu	Σ σ	Sigma	Ω ω	Omega

3.1.5 SI units

The International System of Units, also referred to as SI (Abbreviation for French: *Système International d'unités*), embodies the modern metric system and is the most widely used units system for physical units. The system was originally established in response to demands from the field of science and research, however it is now the prevalent units system for the economic, technological and trade industries. In the European Union (EU) and the majority of other states, the use of the SI units system in official and business transactions is prescribed by law; however there are many national exceptions to this rule.

SI Base units

The SI units system is composed of seven base units. In order to use the base units for applications involving different scales, certain prefixes such as Kilo or Milli are used. These are also used in conjunction with derived units and, to some extent, with units from other systems.

Basic unit	Dimension Symbol	Quantity (metric)	Unit (metric)	Quantity (US)	Unit (US)
Length	L	Meter	m	Feet	ft
Mass	m	Kilogram	kg	Pound	lb
Time	t	Second	s	Second	s
Electric current	I	Ampere	A	Ampere	A
Thermodynamic temperature	T	Kelvin	K	Rankine	R
Amount of substance	N	Mol	mol	Mol	mol
Luminous intensity	J	Candela	cd	Candela	cd

3.1.6 SI derived units with special names

In addition to the base units, the International System of Units also includes derived units, which are made up of one or more of these base units by means of multiplication or division. The clearly defined product of powers of the base units are not referred to as a dimension of the physical size as such, but rather the system is formally structured in that way. It is possible for example to express areas in terms of meters square (m^2) or speeds in meters per second (m/s).

Some of these compounded units are assigned names and symbols, which can even be combined once again with all of the base units and derived units. The SI unit "force" for example, the Newton ($1\text{ N} = 1\text{ kg m/s}^2$), lends itself to express the unit "energy", the Joule ($1\text{ J} = 1\text{ kg m}^2/\text{s}^2$), which is equal to the equation Newtons multiplied by meters. The following 22 derived units have their own name and unit symbol.

Notable US units are given in an additional table.

3.1 Units, conversion factors and tables

3.1.6a SI derived units with special names (European units)

Name	Symbol	Quantity	Unit	Expression in terms of original SI Units
Plain angle	α, β, \dots	Radian	rad	$\frac{m}{m} \left(= \frac{360^\circ}{2\pi} \right)$
Solid angle	ω	Steradian	sr	$\frac{m^2}{m^2}$
Frequency	f	Hertz	Hz	$\frac{1}{s}$
Force, weight	F	Newton	N	$\frac{kg \cdot m}{s^2}$
Pressure, stress	p	Pascal	Pa	$\frac{kg}{s^2 \cdot m} = \frac{N}{m^2}$
Energy, work, heat	E, W	Joule	J	$\frac{kg \cdot m^2}{s^2} = W \cdot s = N \cdot m$
Power, radiant flux	P	Watt	W	$\frac{kg \cdot m^2}{s^3} = N \cdot \frac{m}{s} = \frac{J}{s} = V \cdot A$
Voltage, electrical potential difference	U	Volt	V	$\frac{kg \cdot m^2}{s^3 \cdot A} = \frac{W}{A} = \frac{J}{C}$
Electric charge or electric flux	Q	Coulomb	C	A · s
Magnetic flux	ϕ	Weber	Wb	$\frac{kg \cdot m^2}{s^2 \cdot A} = V \cdot s$
Electrical resistance	R	Ohm	Ω	$\frac{kg \cdot m^2}{s^3 \cdot A^2} = \frac{V}{A}$
Electrical conductance	G	Siemens	S	$\frac{s^3 \cdot A^2}{kg \cdot m^2} = \frac{1}{\Omega}$
Inductance	L	Henry	H	$\frac{kg \cdot m^2}{s^2 \cdot A^2} = \frac{Wb}{A}$
Electrical capacitance	C	Farad	F	$\frac{A^2 \cdot s^4}{kg \cdot m^2} = \frac{C}{V}$
Magnetic field	B	Tesla	T	$\frac{kg}{s^2 \cdot A} = \frac{Wb}{m^2}$
Celsius-temperature	ϑ (or t)	degrees Celsius	°C	0°C = 273,15 K 1°C = 274,15 K
Luminous flux	ϕ_v	Lumen	lm	cd · sr
Illuminance	E_v	Lux	lx	$\frac{cd \cdot sr}{m^2} = \frac{lm}{m^2}$
Radioactivity (decays per unit time)	A	Becquerel	Bq	$\frac{1}{s}$
Absorbed dose (of ionizing radiation)	D	Gray	Gy	$\frac{J}{kg}$
Equivalent dose (of ionizing radiation)	H	Sievert	Sv	$\frac{J}{kg}$
Catalytic activity	z	Katal	kat	$\frac{mol}{s}$

3.1.6b SI derived units with special names (US units)

Name	Symbol	Quantity (US)	Unit	Expression in terms of original Units
Force, weight	F	Pound-Force	lb _f	$\frac{\text{lb} \cdot \text{in}}{\text{s}^2}$
Pressure, stress	p	Pound-Force per square inch	PSI	$\frac{\text{lb}}{\text{in} \cdot \text{s}^2}$
Energy, work, heat	E, W	British-Thermal-Unit	BTU	$\frac{\text{lb} \cdot \text{in}^2}{\text{s}^2}$
Celsius-temperature	z	degrees Fahrenheit	°F	$\frac{0^\circ\text{F} = 459.67^\circ\text{R}}{32^\circ\text{F} = 491.67^\circ\text{R}}$

3.1 Units, conversion factors and tables

3.1.7 Compound units derived from SI-units

Name	Quantity	Symbol	Definition (Units)
Volume	Litre	l, L	1 l = 1 dm ³ = 1L
Time	Minute Hour Day Year	min h d yr	1 min = 60 s 1 h = 60 min = 3600 s 1 d = 24 h = 1440 min 1 yr = 365 d = 8760 h
Mass	Tonnes Grams	t g	1 t = 1.000 kg 1 g = 0.001 kg
Pressure	Bar	bar	1 bar = 10 ⁵ Pa = 10 ⁵ N/m ²
US Customary Units			
Volume (liquid)	Pint Quart Gallon Barrel (oil barrel)	pt qt gal bbl bbl	1 pint = 2 cups 1 quart = 2 pints 1 gallon = 4 quarts 1 barrel = 31.5 gallons 1 oil barrel = 42 gallons
Volume	cubic inch cubic foot cubic yard	in ³ ft ³ yd ³	1ft ³ = 1728 in ³ 1 yd ³ = 27 ft ³
Volume	1 board foot		1 ft x 1 ft x 1 in
Length	inch foot yard mile	in ft yd mi	1 in = 12pica 1 ft = 12in 1 yd = 3ft 1760 yd = 1mi
Time	Minute Hour Day Year	min h d yr	1 min = 60 s 1 h = 60 min = 3600 s 1 d = 24 h = 1440 min 1 year = 365 d = 8760 h
Mass	Ton Pound Ounce Grain	t lb oz gr	1 long ton = 2240 lb 1 short ton = 2000 lb 1 US hundred weight = 100 lb 1 lb = 16 oz 1 lb = 7000 grain
Pressure	Pound-Force per square foot	PSF	
	Pound-Force per square inch	PSI	1PSI = 144 PSF
	Atmosphere	atm	1atm = 14.70 PSI

3.1.8 Temperature scales and conversions

Temperature scale		Unit	Conversion formulas		
			Kelvin	Celsius	Fahrenheit
Kelvin	(T_K)	K		$T_K \approx 273 + T_C$	$T_K \approx 255 + 5/9 * T_F$
Celsius	(T_C)	°C	$T_C \approx T_K - 273$		$T_C \approx 5/9 * (T_F - 32)$
Fahrenheit	(T_F)	°F	$T_F \approx 9/5 T_K - 459$	$T_F \approx 9/5 * T_C + 32$	

3.1.9 Conversion degrees Celcius and Fahrenheit

The white columns show the temperature in degrees Celsius and the grey columns show the temperature values in degrees Fahrenheit. If you

need to convert a temperature from Celsius to Fahrenheit, use the value shown in the grey column. If you need to convert a temperature from Fahrenheit to Celsius, use the value shown in the white column.

°C	°F	°C	°F	°C	°F	°C	°F	°C	°F
-200	-328	-10	14	180	356	370	698	560	1040
-190	-310	0	32	190	374	380	716	570	1058
-180	-292	10	50	200	392	390	734	580	1076
-170	-274	20	68	210	410	400	752	590	1094
-160	-256	30	86	220	428	410	770	600	1112
-150	-238	40	104	230	446	420	788	610	1130
-140	-220	50	122	240	464	430	806	620	1148
-130	-202	60	140	250	482	440	824	630	1166
-120	-184	70	158	260	500	450	842	640	1184
-110	-166	80	176	270	518	460	860	650	1202
-100	-148	90	194	280	536	470	878	660	1220
-90	-130	100	212	290	554	480	896	670	1238
-80	-112	110	230	300	572	490	914	680	1256
-70	-94	120	248	310	590	500	932	690	1274
-60	-76	130	266	320	608	510	950	700	1292
-50	-58	140	284	330	626	520	968	710	1310
-40	-40	150	302	340	644	530	986	720	1328
-30	-22	160	320	350	662	540	1004	730	1346
-20	-4	170	338	360	680	550	1022	740	1364

3.1 Units, conversion factors and tables

3.1.10 Imperial (Anglo-Saxon) units

The Anglo-Saxon units (also referred to as Anglo-American measurement systems) are derived from old English systems and were also used in other Commonwealth states prior to the

implementation of the metric system. Nowadays, it is primarily used in the USA and to some extent in Great Britain and in some of the Commonwealth states.

Imperial unit, conversion to SI-Units:

Length, distance

Imperial Units	Symbol	Conversion to SI-Units
1 inch	in.	2.539998 cm (UK) 2.540005 cm (USA)
1 foot	ft.	30.48 cm
1 yard	yd.	91.44 cm
1 mile	mi.	1.609 km
1 nautical mile	nmi.	1.853 km

Area measurements

Imperial Units	Symbol	Conversion to SI-Units
1 square inch	(sq.in.)	6.45 cm ²
1 square foot	(sq.ft.)	929.03 cm ²
1 square yard	(sq.yd.)	0.836 m ²

Overview Imperial units and conversion to SI-Units:

Standard measures of volume

Imperial Units	Symbol	SI-Units
1 cubic inch	(cu.in.)	16.39 cm ³
1 cubic foot	(cu.ft.)	28.32 dm ³
1 cubic yard	(cu.yd.)	0.7646 m ³

Specific measures of volume

Imperial Units	Symbol	SI-Units
1 gallon	(gal.)	4.546 dm ³ (UK) 3.787 dm ³ (USA)
1 barrel	(bbl.)	163.7 dm ³ (UK) 119.2 dm ³ (USA) 158.8 dm ³ (USA, oil)

Measures of weight and mass

Imperial Units	Symbol	SI-Units
1 ounce	(oz)	28.35 g
1 pound	(lb)	0.4536 kg

Density

Imperial Units	SI-Units
1 lb/cu.in. (= 1lb/in ³)	2.766*10 ⁴ kg/m ³
1 lb/cu.ft. (= 1 lb/ft ³)	16.02 kg/m ³

3.1 Units, conversion factors and tables

3.1.10 Imperial (Anglo-Saxon) units

Overview Imperial units and conversion to SI-Units:

Force, weight

Imperial Units	SI-Units
1 lbf (lb. Force)	4.448 N

Energy, work, heat

Imperial Units	SI-Units
1 BTU	1055.06 J

Power, capacity

Imperial Units	SI-Units
1 BTU/sec	1055.06 W
1 BTU/h	0.293 W
1 hp	745.7 W

Pressure, stress

Imperial Units	SI-Units
1 lbg/sq in.	6894.7 N/m ²
1 lbg/sq ft	47.88 N/m ²

Speed

Imperial Units	SI-Units
1 Knot intern. (kn.)	0.514 m/s 1.852 km/h
1 inch/second	0.0254 m/s 0.0914 km/h
1 foot/second (ft./s.)	0.3048 m/s 1.0973 km/h
1 yard/second (yd./s.)	0.9144 m/s 3.294 km/h
1 yard/minute (yd./min.)	0.01524 m/s 0.055 km/h
1 mile per hour (m.p.h.)	0.447 m/s 1.609 km/h

3.1.11 Conversion of energy and heat scales

Unit	Joule (J)	Kilojoule (kJ)	Megajoule (MJ)	Kilowatt hours (kWh)	Kilocalorie (Kcal)	British Thermal Unit (BTU)
Joule (J)		0.001	10^{-6}	2.78×10^{-7}	2.39×10^{-4}	9.479×10^{-4}
Kilojoule (kJ)	1000		0.001	2.7810×10^{-4}	0.239	0.948
Megajoule (MJ)	10^6	1000		0.278	238.8	948
Kilowatt hours (kWh)	3.6×10^6	3600	3.6		859.8	3412.3
Kilocalorie (Kcal)	4187	4.187	4.19×10^{-3}	1.2×10^{-3}		3.873
British Thermal Unit (BTU)	1055	1.055	1.055×10^{-3}	2.933×10^{-4}	0.252	

3.1.12 Conversion of power scales

Unit	Watt (W)	Kilowatt (kW)	Kilocalorie per second (kcal/s)	Horsepower (HP)	British Thermal Unit per second (BTU/s)	British Thermal Unit per hour (BTU/h)
Watt (W)		0.001	2.39×10^{-4}	1.36×10^{-3}	0.948×10^{-3}	3415.2×10^{-3}
Kilowatt (kW)	1000		0.239	1.36	0.948	3415.2
Kilocalorie per second (kcal/s)	4186.8	4.187		5.692	3.968	1.429×10^3
Horse power (HP)	735.5	0.736	0.176		0.698	2551.9
British Thermal Unit per second (BTU/s)	1055.06	1.06	0.252	1.433		3600
British Thermal Unit per hour (BTU/h)	0.293	2.93×10^{-4}	7.000×10^{-5}	3.981×10^{-4}	2.777×10^{-3}	

3.1 Units, conversion factors and tables

3.1.13 Conversion of pressure scales

Unit	Pascal (Pa)	Bar	atm	lb/sq ft	lb/sq in.
Pascal (Pa)		10 ⁻⁵	9.869 * 10 ⁻⁶	0.201	1.450 * 10 ⁻⁴
Bar	10 ⁵		0.987	2088.5	13.50
atm	101325	1.013		2116.2	14.70
lb/sq ft.	47.88	4.788 * 10 ⁻⁴	4.723 * 10 ⁻⁴		6.944 * 10 ⁻³
lb/sq in.	6894.8	0.0689	0.0680	144.00	

3.1.14 Conversion of SI-units into Imperial units, pre-SI units and technical scales

Symbol	Quantity	SI-Unit	Technical scales	Imperials units
Q	Heat. energy	J	kcal = 4186.8 J	1 BTU = 1055.06 J
Q	Energy. heat flux	W/m ²	$\frac{\text{kcal}}{\text{m}^2 \text{ h}} = 1.163 \frac{\text{W}}{\text{m}^2}$	$\frac{1 \text{ BTU}}{(\text{sq.ft.hr.})} = 3.1546 \frac{\text{W}}{\text{m}^2}$
λ	Thermal conductivity	W/(m K)	$\frac{\text{kcal}}{\text{m}^2 \text{ h}} = 1.163 \frac{\text{W}}{(\text{m K})}$	$\frac{1 \text{ BTU}}{(\text{ft.hr.}^\circ\text{F})} = 1.7307 \frac{\text{W}}{(\text{m K})}$ $\frac{1 \text{ BTU in}}{(\text{sq.ft.hr.}^\circ\text{F})} = 0.1442 \frac{\text{W}}{(\text{m K})}$ $\frac{1 \text{ BTU}}{(\text{in.hr.}^\circ\text{F})} = 20.7688 \frac{\text{W}}{(\text{m K})}$
R	Heat resistivity coefficient (R-value)	m ² K/W	$1 \frac{\text{m}^2}{\text{h}} \frac{\text{K}}{\text{kcal}} = 0.86 \frac{\text{m}^2}{\text{W}}$	$\frac{1 \text{ sq.ft.hr.}^\circ\text{F}}{\text{BTU}} = 0.1761 \frac{\text{m}^2}{\text{W}}$
α	Heat transfer coefficient	W/(m ² K)	$\frac{\text{kcal}}{(\text{m}^2 \text{ h K})} = 1.163 \frac{\text{W}}{(\text{m}^2 \text{ K})}$	$\frac{1 \text{ BTU}}{(\text{sq.ft.hr.}^\circ\text{F})} = 5.6783 \frac{\text{W}}{(\text{m}^2 \text{ K})}$
Cp	specific heat capacity	kJ/(kg K)	$\frac{\text{kcal}}{(\text{kg K})} = 4.1868 \frac{\text{kJ}}{\text{kg K}}$	$\frac{1 \text{ BTU}}{(\text{lb. }^\circ\text{F})} = 4.1868 \frac{\text{kJ}}{(\text{kg K})}$
C	Radiant coefficient	W/(m ² K ⁴)	$\frac{\text{kcal}}{(\text{m}^2 \text{ h K}^4)} = 1.63 \frac{\text{W}}{(\text{m}^2 \text{ K}^4)}$	$\frac{1 \text{ BTU}}{(\text{sq.ft.hr.}^\circ\text{R}^4)} = 33.156 \frac{\text{kJ}}{(\text{m}^2 \text{ K}^4)}$

3.1.15 Density Conversion table

Density

Imperial conversion to SI:

lb / ft ³	kg / m ³	lb / ft ³	kg / m ³
1	16	8.75	140
1.25	20	9	144
1.5	24	9.25	148
1.75	28	9.5	152
2	32	9.75	156
2.25	36	10	160
2.5	40	10.25	164
2.75	44	10.5	168
3	48	10.75	172
3.25	52	11	176
3.5	56	11.25	180
3.75	60	11.5	184
4	64	11.75	188
4.25	68	12	192
4.5	72	12.25	196
4.75	76	12.5	200
5	80	12.75	204
5.25	84	13	208
5.5	88	13.25	212
5.75	92	13.5	216
6	96	13.75	220
6.25	100	14	224
6.5	104	14.25	228
6.75	108	14.5	232
7	112	14.75	236
7.25	116	15	240
7.5	120	15.25	244
7.75	124	15.5	248
8	128	15.75	252
8.25	132	16	256
8.5	136		

SI conversion to Imperial:

kg / m ³	lb / ft ³	kg / m ³	lb / ft ³
20	1.25	125	7.80
25	1.56	130	8.12
30	1.87	135	8.43
35	2.18	140	8.74
40	2.50	145	9.05
45	2.81	150	9.36
50	3.12	155	9.68
55	3.43	160	9.99
60	3.75	165	10.30
65	4.06	170	10.61
70	4.37	175	10.92
75	4.68	180	11.24
80	4.99	185	11.55
85	5.31	190	11.86
90	5.62	195	12.17
95	5.93	200	12.49
100	6.24	205	12.80
105	6.55	210	13.11
110	6.87	215	13.42
115	7.18	220	13.73
120	7.49		

3. Tables

3.2 Product properties insulation and cladding materials

3.2.1 Insulation materials

The characteristic properties of the individual ProRox products are described in Chapter 4. For special applications, such as high-temperature insulation systems, cold insulation products or an additional spacer, it may be necessary to use ProRox products in connection with other insulation products. These may include, for example:

- CMS Calcium-Magnesium-Silicate fibers for high-temperature insulations
- Cellular glass as a spacer or as a support

In any case, it is important that the product properties and processing instructions are taken into consideration during the application of these products. Further product information can be found in the various standards and regulations, such as DIN 4140, CINI, VDI 2055 and various other ASTM standards for example.

3.2.2 Cladding materials

3.2.2.1 Application selector for claddings

Cladding material	Fire hazardous environment	Corrosive environment	Maximum surface (cladding) temperature		
			< 120°F (50°C)	< 140°F (60°C)	> 140°F (60°C)
Aluminum	-	-			+
Alu-zinc steel	-	-			+
Galvanized steel	+	-			+
Stainless steel					
Aluminized steel	+	+			+
Painted steel or aluminum	-	-		+	
Glass-fiber reinforced polyester	-	+			190°F (90°C)
Mastics	-	-			175°F (80°C)
Foils	-	-	+		

- not recommendable

+ suitable in general

The selection of material should be geared to each installation and/or environment.

3.2.2.2 Product properties and standards

Cladding material	Density (kg/m ³)	Linear expansion coefficient 10 ⁻⁶ K ⁻¹	Emissivity	Type of material	Standard(s)
Aluminium, bright	2700	23.8	0.05	Al Mg2 Mn 0,8 EN AW 5049	DIN EN 485-2
Aluminium, oxydised	2700	23.8	0.13	Al MG 3 EN AW 5745 AL 99,5 EN AW 1050	CINI 3.1.01 DIN EN 12258-1 DIN EN 13195-1
Galvanised steel, bright	7800 - 7900	11.0	0.26	DX 51 D	CINI 3.1.03, DIN EN 10327
Galvanised steel, oxidised	7800 - 7900	11.0	0.44		
Stainless steel	7700 - 8100	16.0	0.15	1.4301, 1.451, 14571	CINI 3.1.05, EDIN EN 10028-7, EN 10088-3
Alu-zinc steel, bright	-	-	0.16		
Alu-zinc steel, oxidised	-	-	0.18		
Aluminised steel	7800 - 7900	11.0	-	DX 51 D	CINI 3.1.02, DIN EN 10327
Painted steel	-	-	0.90		see data sheet of the manufacturer
Glass fibre reinforced polyester	-	-	0.90		see data sheet of the manufacturer or CINI 3.2.11

3.2.2.3 Thermal elongation of steel (in mm/m) according to DIN 4140 (Table 1)

Type of steel	Temperature difference Δt in K				
	100	200	300	400	500
Carbon steel	1.3	2.6	4.1	5.6	7.2
16 Mo 3 Alloyed steel	1.1	2.4	3.8	5.4	7.0
1.4301/1.4828 Stainless steel	1.6	3.3	5.1	7.0	9.0

3.2 Product properties insulation and cladding materials

3.2.2 Cladding materials

3.2.2.4 Thermal coefficients for metals based on ASME B31.3 (Table C-3)

Mean coefficient of linear thermal expansion between 700 F and indicated temperature, $\mu\text{in./in. } ^\circ\text{F}$

Temp. $^\circ\text{F}$	Material	
	Carbon Steel Carbon-Moly-Low-Chrome (Through 3Cr-Mo)	Austenitic Stainless Steel (18 Cr-8Ni)
25	5.96	9.03
50	6.01	9.07
70	6.07	9.11
100	6.13	9.16
150	6.25	9.25
200	6.38	9.34
250	6.49	9.41
300	6.60	9.47
350	6.71	9.53
400	6.82	9.59
450	6.92	9.65
500	7.02	9.70
550	7.12	9.76
600	7.23	9.82
650	7.33	9.87
700	7.44	9.92
750	7.54	9.99
800	7.65	10.05
850	7.75	10.11
900	7.84	10.16
950	7.91	10.23
1000	7.97	10.29
1050	8.05	10.34
1100	8.12	10.39
1150	8.16	10.44
1200	8.19	10.48

3.2.2.5 Thickness metal cladding in accordance with CINI

External diameter insulation (mm)	Sheet thickness in mm				
	Aluminum (CINI 3.1.01)	Aluminized steel (CINI 3.1.02)	Alu-zinc steel (CINI 3.1.03)	Galvanized steel (CINI 3.1.04)	Stainless steel (CINI 3.1.05)
< 140	0.6	0.56	0.5	0.5	0.5
130 - 300	0.8	0.8	0.8	0.8	0.8
> 300	1.0	0.8	0.8	0.8	0.8

NOTE: Metric values above are from CINI standard. For US units refer to table on page 39.

3.2.2.6 Thickness metal cladding in accordance with DIN 4140

External diameter insulation (mm)	Minimum sheet thickness			Overlap	
	Galvanized. Aluminized. Alu-zinc and painted steel	Stainless steel E DIN EN 10028-7 and DIN EN 10088-3	Aluminum	Longitudinal joint	Circumferential joint
up to 400	0.5	0.5	0.6	30	50
400 to 800	0.6	0.5	0.8	40	
800 to 1200	0.7	0.6	0.8	50	
1200 to 2000	0.8	0.6	1.0		
2000 to 6000	1.0	0.8	1.0		
> 6000	1.0	0.8	1.2		

^a Smaller sheet thicknesses are also possible in consultation with the customer.

^b With regard to pipes, the circumferential joint overlap can be omitted if the circumferential joints are joined by swage and counter swage. In the case of cladding with a large surface area and high wind loads, structural verifications may be required. In that instance, only those binding agents permitted by the building authorities may be used. The DIN 1055-4 applies in respect of the loading assumptions.

3.2 Product properties insulation and cladding materials

3.2.2 Cladding materials

3.2.2.7 Thickness of metal cladding in accordance with BS 5970

Type of area	Protected mild steel		Aluminum		Stainless steel	
	Flat mm	Profiled mm	Flat mm	Profiled mm	Flat mm	Profiled mm
Large flat areas over flexible insulation	1.2	0.8	1.6	0.9	1.0	0.6
Smaller flat areas over flexible insulation, or large areas over pre-formed boards/slabs (including large curved surfaces)	1.0	0.8	1.2	0.9	0.8	0.5
Removable insulated manhole and door covers	1.6	-	1.6	-	1.0	-
Flange and valve boxes	As metal on adjacent pipe					
Pipes with an insulated diameter of more than 450 mm	1.0	-	1.2	-	0.8	-
Pipes with an insulated diameter of 150 mm to 450 mm	0.8	-	0.9	-	0.6	-
Pipes with an insulated diameter of less than 150 mm ^a	0.6	-	0.7	-	0.5	-
<i>Recommended thickness for reinforcing plates and where foot traffic is likely</i>						
For flat surfaces, large curved areas and pipes with an insulated diameter of 450 mm or more	1.6	-	1.6	-	1.0	-
For pipes with an insulated diameter of less than 450 mm	1.0	-	1.2	-	0.8	-
<i>Recommended thickness where no mechanical damage is likely</i>						
For pipes with an insulated diameter of less than 1000 mm	0.3	-	0.3	-	0.3	-
For pipes with an insulated diameter of more than 1000 mm	0.4	-	0.4	-	0.4	-

^a For insulation diameters of 150 mm or less, the thickness of reeded aluminum should be not less than 0.25 mm. For insulation diameters in excess of 150 mm, it should be 0.4 mm or greater.

3. Tables

3.3 Usage tables

3.3.1 Construction materials

Material	Density		Thermal conductivity		Specific heat capacity		Linear expansion	
	lb / ft ³	kg/m ³	BTU.in / (ft ² .hr.°F) at 75 °F	W/(mK) at 20°C	BTU / (lb °F)	kJ/ (kg K)	coefficient 10 ⁻⁶ R ⁻¹	coefficient 10 ⁻⁶ K ⁻¹
Aluminum	169	2700	1532	221	0.220	0.92	13.33	23.8
Concrete	150	2400	14.6	2.1	0.22 - 0.26	0.92 - 1.09	6.16 - 6.72	11.0 - 12.0
Bitumen (Solid)	66	1050	1.18	0.17	0.41 - 0.46	1.72 - 1.93	112	200.0
Bronze, red brass	512	8200	423	61	0.088	0.37	9.8	17.5
Cast iron	490 - 443	7100 - 7300	291 - 437	42 - 63	0.129	0.54	5.82	10.4
Wrought (cast) iron	487	7800	465	67	0.110	0.46	6.55	11.7
Copper	559	8960	2725	393	0.096	0.40	9.24	16.5
Wet soil	100 - 125	1600 - 2000	8.3 - 20.8	1.2 - 3.0	0.478	2.0	-	-
Dry soil	87 - 100	1400 - 1600	2.8 - 4.2	0.4 - 0.6	0.201	0.84	-	-
Stainless steel	481 - 506	7700 - 8100	69 - 319	10 - 46	0.119	0.50	8.96	16.0
Iron	490	7850	319 - 361	46 - 52	0.115	0.48	6.16	11.0

3.3 Usage tables

3.3.2 Fluids which are commonly used in process industry

Group	Material	Density		Specific heat capacity	
		lb/ft ³	kg/m ³	BTU/(lb F) at 70°F	kJ/(kg K) at 20°C
General	Water	62.5	1000	1.001	4.19
Alcohols	Ethanol	44.5	714	0.559	2.34
	Methanol	49.5	792	0.596	2.495
Food	Beer	64	1030	0.900	3.77
Milk	Milk	64	1030	0.941	3.94
	Olive oil	57.5	920	0.471	1.97
Fuels	Petrol	38.5 to 49	620 - 780	0.482	2.02
	Diesel	52	830	0.461	1.93
	Fuel oil (HEL)	53	850	0.449	1.88
	Fuel oil (HS)	61	980	0.411	1.72
	Petroleum	49	790	0.525	2.20
Oils	Silicone oil	59	940		
	Machine oil	57	910	0.399	1.67
Acids	Hydrochloric acid (10%)	67	1070		-
	Hydrochloric acid (30%)	72	1150	0.869	3.64
	Nitric acid (10 %)	65.5	1050		-
	Nitric acid (<90%)	93.5	1500	0.411	1.72
	Sulfuric acid (10%)	67	1070		
	Sulfuric acid (50%)	87.5	1400		
	Sulfuric acid (100%)	115	1840	0.253	1.06
Bases	Ammonia (30%)	38	609	1.132	4.74
	Sodium hydroxide (50%)	95	1524		
Various	Benzol	55	879	0.413	1.73
	Dichlormethane	83.5	1336	0.277	1.16
	Toluene	54	867	0.411	1.72
	Bitumen (fluid)	68 to 94	1100 - 1500	0.499 to 0.549	2.09 - 2.3

3.3.3 Gases which are commonly used in process industry

Gas	Density		Specific heat capacity	
	at 1 bar lb/f ³	at 1 bar kg/m ³	BTU/(lb F) at 70°F	kJ/(kg K) at 20°C
Acetylene	0.067	1.070	0.403	1.687
Ammonia	0.044	0.710	0.500	2.093
Chlorine	0.184	2.950	0.114	0.477
Ethane	0.077	1.240	0.419	1.754
Ethylene	0.072	1.150	0.371	1.553
Carbon dioxide	0.111	1.780	0.202	0.846
Carbon monoxide	0.072	1.150	0.248	1.038
Air	0.074	1.190	0.241	1.007
Methane	0.041	0.660	0.532	2.227
Propane	0.115	1.850	0.399	1.671
Oxygen	0.082	1.310	0.218	0.913
Nitrogen	0.072	1.150	0.248	1.038
Hydrogen	0.051	0.820	3.425	14.34

3.3.4 Conversion factors in relation to the heat of combustion

Fuel	Heat of combustion		Conversion Factor		Conversion factor	
	MBTU/1000lb	TJ/Gg	lb CO ₂ /MBTU	tCO ₂ / TJ	lb CO ₂ /lb fuel	kg CO ₂ /kg fuel
Oil	18.2	42.3	170	73.3	3.1	3.1
Liquified gas	19.0	44.2	149	64.1	28.3	28.3
Petrol	19.0	44.3	161	69.2	3.1	3.1
Kerosene	18.8	43.8	167	71.8	3.1	3.1
Diesel	18.5	43.0	172	74.0	3.2	3.2
Ethane	19.9	46.4	143	61.6	2.9	2.9
Petroleum cokes	14.0	32.5	227	97.5	3.2	3.2
Black coal	12.1	28.2	220	94.5	2.7	2.7
Brown coal	5.1	11.9	235	101.1	1.2	1.2
Gas cokes	12.1	28.2	249	107.0	3	3.0
Gas	20.6	48.0	130	56.1	2.7	2.7

3.3 Usage tables

3.3.5 Specific enthalpy super heated steam in kJ/kg

Pressure in bar	Steam temperature in °C											
	150	200	250	300	350	400	450	500	600	700	800	
1	2776.1	2874.8	2973.9	3073.9	3175.3	3278	3382.3	3488.2	3705	3928.8	4159.7	
5		2854.9	2960.1	3063.7	3167.4	3271.7	3377.2	3483.9	3701.9	3926.5	4157.8	
10		2827.4	2941.9	3050.6	3157.3	3263.8	3370.7	3478.6	3698.1	3923.6	4155.5	
20			2901.6	3022.7	3136.6	3247.5	3357.5	3467.7	3690.2	3917.6	4150.9	
30			2854.8	2922.6	3114.8	3230.7	3344.1	3456.6	3682.3	3911.7	4146.3	
40				2959.7	3091.8	3213.4	3330.4	3445.4	3674.3	3905.7	4141.7	
50				2923.5	3067.7	3195.5	3316.3	3433.9	3666.2	3899.7	4137	
60				2883.2	3042.2	3177	3301.9	3422.3	3658.1	3893.6	4132.3	
70				2837.6	3015.1	3157.9	3287.3	3410.5	3649.8	3887.5	4127.6	
80				2784.6	2986.3	3138	3272.2	3398.5	3641.5	3881.4	4122.9	
90					2955.5	3117.5	3256.9	3386.4	3633.2	3875.2	4118.2	
100					2922.2	3096.1	3241.1	3374	3624.7	3869	4113.5	
150					2691.3	2974.7	3156.6	3309.3	3581.5	3837.6	4089.6	
200						2816.9	3060.8	3239.4	3536.7	3805.5	4065.4	
250						2578.1	2950.6	3164.2	3490.4	3773	4041.1	
300						2150.7	2822.3	3083.5	3443.1	3740.1	4016.7	
350							1988.3	2672.9	2997.3	3394.7	3706.9	3992.2
400							1930.8	2513.2	2906.7	3345.8	3673.8	3967.8
450							1897.3	2377.7	2814.2	3296.6	3640.7	3943.6
500							1874.1	2284.7	2724.2	3247.7	3607.8	3919.5
600							1843.0	2180.0	2571.9	3152.3	3543.5	3872.3
700							1822.8	2123.6	2466.9	3063.8	3481.9	3826.7
800							1808.7	2087.9	2397.7	2985.4	3424.2	3783.3
900							1798.4	2063.2	2350.3	2918.7	3371.1	3742.4
1000							1790.9	2045.1	2316.2	2863.4	3323.1	3704.3

3.3.6 Density super heated steam kg/m³

Pressure in bar	Steam temperature in °C										
	150	200	250	300	350	400	450	500	600	700	800
1	0.52	0.46	0.42	0.38	0.35	0.32	0.30	0.28	0.25	0.22	0.20
5		2.35	2.11	1.91	1.75	1.62	1.51	1.41	1.24	1.11	1.01
10		4.86	4.30	3.88	3.54	3.26	3.03	1.82	2.49	2.23	2.02
20			8.98	7.97	7.22	6.61	6.12	5.69	5.01	4.48	4.05
30			14.17	12.33	11.05	10.07	9.27	8.61	7.55	6.74	6.09
40				17.00	15.05	13.62	12.50	11.57	10.12	9.01	8.14
50				22.07	19.26	17.30	15.80	14.59	12.71	11.30	10.19
60				27.66	23.69	21.10	19.18	17.65	15.33	13.60	12.25
70				33.94	28.38	25.05	22.65	20.78	17.97	15.91	14.32
80				41.23	33.39	29.14	26.20	23.96	20.64	18.24	16.39
90					38.78	33.41	29.86	27.20	23.34	20.58	18.47
100					44.61	37.87	33.61	30.50	26.07	22.94	20.56
150					87.19	63.89	51.20	48.08	40.15	34.94	31.12
200						100.54	78.73	67.71	55.04	47.32	41.87
250						166.63	109.09	89.90	70.79	60.08	52.80
300						358.05	148.45	115.26	87.48	73.23	63.92
350						474.89	201.63	144.43	105.15	86.78	75.21
400						523.67	270.91	177.97	123.81	100.71	86.68
450						554.78	343.37	215.87	143.44	115.01	98.31
500						577.99	402.28	256.95	163.99	129.64	110.09
600						612.45	479.87	338.44	207.20	159.77	134.02
700						638.30	528.62	405.76	251.73	190.65	158.30
800						659.27	563.69	456.99	295.45	221.74	182.72
900						677.05	591.14	496.53	336.53	252.48	207.03
1000						692.58	613.80	528.21	373.93	282.36	231.03

3.3 Usage tables

3.3.7.1a Dew point table (Imperial units)

Air temperature	Maximum water content grain/ft ³	Maximum cooling (°F) of air temperature (to avoid condensation) at a humidity of													
		30%	35%	40%	45%	50%	55%	60%	65%	70%	75%	80%	85%	90%	95%
-22	0.15	20.0	17.6	15.5	13.5	11.9	10.3	8.8	7.6	6.3	5.0	4.0	2.9	2.0	1.1
-13	0.24	20.7	18.2	16.0	14.0	12.2	10.6	9.2	7.7	6.5	5.2	4.1	3.1	2.0	1.1
-4	0.39	21.6	18.7	16.4	14.4	12.6	10.8	9.4	8.1	6.7	5.2	4.1	3.1	2.0	1.1
5	0.61	22.1	19.4	17.3	14.9	13.1	11.5	9.7	8.3	6.8	5.6	4.5	3.2	2.2	1.1
14	0.95	23.2	20.3	17.8	15.7	13.7	11.9	10.3	8.6	7.0	5.8	4.5	3.2	2.2	1.1
23	1.43	24.1	21.1	18.5	16.2	14.2	12.2	10.6	9.0	7.4	5.9	4.7	3.4	2.2	1.1
32	2.10	25.0	22.0	19.3	16.7	14.6	12.8	10.8	9.2	7.6	6.3	4.9	3.4	2.3	1.3
36	2.45	25.7	22.7	19.8	17.5	15.3	13.3	11.5	9.7	8.3	6.8	5.4	4.0	2.7	1.3
39	2.80	26.5	23.4	20.5	18.2	16.0	13.9	12.1	10.4	8.8	7.2	5.6	4.1	2.7	1.3
43	3.19	27.2	24.1	21.2	18.7	16.6	14.6	12.6	11.0	9.2	7.4	5.8	4.1	2.7	1.3
46	3.63	28.1	24.8	22.0	19.4	17.3	15.1	13.1	11.2	9.2	7.6	5.8	4.1	2.7	1.4
50	4.11	28.8	25.6	22.7	20.2	18.0	17.3	13.3	11.3	9.4	7.6	5.9	4.3	2.9	1.4
54	4.68	29.7	26.3	23.4	20.9	18.2	15.8	13.5	11.5	9.5	7.7	5.9	4.3	2.9	1.4
57	5.29	30.4	27.2	24.1	21.1	18.5	16.0	13.7	11.7	9.7	7.7	6.1	4.5	2.9	1.4
61	5.94	31.3	27.9	24.5	21.4	18.7	16.2	14.0	11.9	9.9	7.9	6.3	4.5	3.1	1.4
64	6.73	32.0	28.3	24.8	21.8	19.1	16.6	14.2	12.1	10.1	8.1	6.3	4.5	3.1	1.4
68	7.56	32.6	28.6	25.2	22.1	19.3	16.7	14.4	12.2	10.1	8.3	6.5	4.7	3.1	1.4
72	8.48	33.1	29.0	25.6	22.5	19.6	17.1	14.6	12.4	10.3	8.5	6.5	4.7	3.1	1.4
75	9.53	33.5	29.5	25.9	22.7	20.0	17.3	14.8	12.6	10.4	8.5	6.7	4.9	3.2	1.4
79	10.66	34.0	29.9	26.5	23.0	20.2	17.5	15.1	12.8	10.6	8.6	6.7	4.9	3.2	1.6
82	11.89	34.6	30.4	26.8	23.4	20.5	17.8	15.3	13.0	10.8	8.8	6.8	5.0	3.2	1.6
86	13.24	35.1	30.8	27.2	23.8	20.9	18.2	15.5	13.1	11.0	9.0	6.8	5.0	3.2	1.6
95	17.22	36.4	31.9	28.3	24.7	21.6	18.7	16.2	13.7	11.3	9.2	7.2	5.2	3.4	1.6
104	22.16	37.6	33.1	29.0	25.6	22.3	19.4	16.7	14.2	11.7	9.5	7.4	5.4	3.6	1.6
113	28.19	38.9	34.2	30.1	26.5	23.0	20.2	17.3	14.6	12.2	9.9	7.7	5.6	3.8	1.6
122	35.96	40.1	35.5	31.1	27.4	24.8	20.9	17.8	15.1	12.6	10.3	7.9	5.8	3.8	1.6
131	45.62	41.4	36.4	32.0	28.1	24.7	21.2	18.4	15.5	12.8	10.4	8.1	5.8	3.8	1.6
140	56.90	42.7	37.6	33.1	29.0	25.4	22.0	18.9	16.0	13.1	10.6	8.3	5.9	3.8	1.6
149	70.49	44.1	38.9	34.2	29.9	26.1	22.7	19.4	16.4	13.7	11.0	8.5	6.1	3.8	1.6
158	82.24	45.4	40.0	35.1	30.8	27.0	23.4	20.0	16.9	14.2	11.2	8.6	6.1	3.8	1.6
167	105.75	46.8	41.2	36.2	31.9	27.7	23.9	20.5	17.3	14.4	11.5	8.8	6.3	4.0	1.6
176	123.84	48.2	42.5	37.3	32.8	28.4	24.7	21.1	17.8	14.8	11.9	9.0	6.5	4.0	1.6

3.3.7.1b Dew point table (SI units)

Air temperature	Maximum water content in g/m ³	Maximum cooling of air temperature (to avoid condensation) at a humidity of													
		30%	35%	40%	45%	50%	55%	60%	65%	70%	75%	80%	85%	90%	95%
-30	0.35	11.1	9.8	8.6	7.5	6.6	5.7	4.9	4.2	3.5	2.8	2.2	1.6	1.1	0.6
-25	0.55	11.5	10.1	8.9	7.8	6.8	5.9	5.1	4.3	3.6	2.9	2.3	1.7	1.1	0.6
-20	0.90	12.0	10.4	9.1	8.0	7.0	6.0	5.2	4.5	3.7	2.9	2.3	1.7	1.1	0.6
-15	1.40	12.3	10.8	9.6	8.3	7.3	6.4	5.4	4.6	3.8	3.1	2.5	1.8	1.2	0.6
-10	2.17	12.9	11.3	9.9	8.7	7.6	6.6	5.7	4.8	3.9	3.2	2.5	1.8	1.2	0.6
-5	3.27	13.4	11.7	10.3	9.0	7.9	6.8	5.9	5.0	4.1	3.3	2.6	1.9	1.2	0.6
0	4.8	13.9	12.2	10.7	9.3	8.1	7.1	6.0	5.1	4.2	3.5	2.7	1.9	1.3	0.7
2	5.6	14.3	12.6	11.0	9.7	8.5	7.4	6.4	5.4	4.6	3.8	3.0	2.2	1.5	0.7
4	6.4	14.7	13.0	11.4	10.1	8.9	7.7	6.7	5.8	4.9	4.0	3.1	2.3	1.5	0.7
6	7.3	15.1	13.4	11.8	10.4	9.2	8.1	7.0	6.1	5.1	4.1	3.2	2.3	1.5	0.7
8	8.3	15.6	13.8	12.2	10.8	9.6	8.4	7.3	6.2	5.1	4.2	3.2	2.3	1.5	0.8
10	9.4	16.0	14.2	12.6	11.2	10.0	9.6	7.4	6.3	5.2	4.2	3.3	2.4	1.6	0.8
12	10.7	16.5	14.6	13.0	11.6	10.1	8.8	7.5	6.4	5.3	4.3	3.3	2.4	1.6	0.8
14	12.1	16.9	15.1	13.4	11.7	10.3	8.9	7.6	6.5	5.4	4.3	3.4	2.5	1.6	0.8
16	13.6	17.4	15.5	13.6	11.9	10.4	9.0	7.8	6.6	5.5	4.4	3.5	2.5	1.7	0.8
18	15.4	17.8	15.7	13.8	12.1	10.6	9.2	7.9	6.7	5.6	4.5	3.5	2.5	1.7	0.8
20	17.3	18.1	15.9	14.0	12.3	10.7	9.3	8.0	6.8	5.6	4.6	3.6	2.6	1.7	0.8
22	19.4	18.4	16.1	14.2	12.5	10.9	9.5	8.1	6.9	5.7	4.7	3.6	2.6	1.7	0.8
24	21.8	18.6	16.4	14.4	12.6	11.1	9.6	8.2	7.0	5.8	4.7	3.7	2.7	1.8	0.8
26	24.4	18.9	16.6	14.7	12.8	11.2	9.7	8.4	7.1	5.9	4.8	3.7	2.7	1.8	0.9
28	27.2	19.2	16.9	14.9	13.0	11.4	9.9	8.5	7.2	6.0	4.9	3.8	2.8	1.8	0.9
30	30.3	19.5	17.1	15.1	13.2	11.6	10.1	8.6	7.3	6.1	5.0	3.8	2.8	1.8	0.9
35	39.4	20.2	17.7	15.7	13.7	12.0	10.4	9.0	7.6	6.3	5.1	4.0	2.9	1.9	0.9
40	50.7	20.9	18.4	16.1	14.2	12.4	10.8	9.3	7.9	6.5	5.3	4.1	3.0	2.0	0.9
45	64.5	21.6	19.0	16.7	14.7	12.8	11.2	9.6	8.1	6.8	5.5	4.3	3.1	2.1	0.9
50	82.3	22.3	19.7	17.3	15.2	13.8	11.6	9.9	8.4	7.0	5.7	4.4	3.2	2.1	0.9
55	104.4	23.0	20.2	17.8	15.6	13.7	11.8	10.2	8.6	7.1	5.8	4.5	3.2	2.1	0.9
60	130.2	23.7	20.9	18.4	16.1	14.1	12.2	10.5	8.9	7.3	5.9	4.6	3.3	2.1	0.9
65	161.3	24.5	21.6	19.0	16.6	14.5	12.6	10.8	9.1	7.6	6.1	4.7	3.4	2.1	0.9
70	188.2	25.2	22.2	19.5	17.1	15.0	13.0	11.1	9.4	7.9	6.2	4.8	3.4	2.1	0.9
75	242.0	26.0	22.9	20.1	17.7	15.4	13.3	11.4	9.6	8.0	6.4	4.9	3.5	2.2	0.9
80	283.4	26.8	23.6	20.7	18.2	15.8	13.7	11.7	9.9	8.2	6.6	5.0	3.6	2.2	0.9

3.3 Usage tables

3.3.8 Climate data

3.3.8.1 Average climate data

North America	Min. Temperature (1% Frequency)		Max. Temperature (1% Frequency)		Winter Wind (1% Frequency)		Condensation			
							Dew Point Temp (1% Frequency)		Mean Coincident Temperature	
	°F	°C	°F	°C	MPH	m/s	°F	°C	°F	°C
Acapulco, Guerrero, MX	69	21	92	33	18.6	8.3	79	26	87	31
Bakersfield, CA	35	2	100	38	18.3	8.2	63	17	85	30
Bangor, ME	-2	-19	84	29	23.5	10.5	68	20	75	24
Boston, MA	13	-11	88	31	26.8	12	71	22	79	26
Casper, WY	-1	-18	91	33	32.2	14.4	55	13	66	19
Charleston, SC	30	-1	92	33	20.4	9.1	78	25	83	29
Chicago,IL	4	-16	89	32	24.6	11	73	23	82	28
Denver, CO	6	-15	92	33	26.8	12	59	15	68	20
El Paso, TX	28	-3	98	37	26.4	11.8	65	19	73	23
Fort McMurray, AB	-28	-34	80	27	18.6	8.3	59	15	69	20
Halifax, NS	3	-16	79	26	27.5	12.3	67	20	72	22
Houston, TX	34	1	95	35	17.7	7.9	77	25	82	28
Long Beach, CA	44	6	88	31	17.0	7.6	67	19	75	24
Louisville, KY	16	-9	92	33	21.0	9.4	74	24	83	28
Memphis, TN	23	-5	94	35	20.1	9	76	24	85	29
Mexico City, DF, MX	42	6	82	28	47.2	21.1	57	14	63	17
Miami, FL	52	11	91	33	20.4	9.1	78	25	83	29
New Orleans, LA	34	1	91	33	18.1	8.1	79	26	84	29
Norfolk, VA	26	-3	91	33	24.8	11.1	76	24	82	28
Pittsburgh, PA	10	-12	87	31	23.0	10.3	71	22	78	26
Quebec City, QC	-10	-23	81	27	25.1	11.2	68	20	75	24
Salt Lake City, UT	14	-10	95	35	25.1	11.2	58	14	73	23
San Francisco, CA	41	5	78	26	28.6	12.8	60	16	67	19
London, ON	4	-15	84	29	23.5	10.5	70	21	77	25
Seattle, WA	30	-1	82	28	20.4	9.1	59	15	68	20
St John's, NFLD	8	-13	74	23	35.6	15.9	65	18	69	21
Tucson, AZ	34	1	104	40	21.5	9.6	68	20	77	25
Veracruz, MX	59	15	92	33	45.2	20.2	79	26	86	30
Minot, ND	-14	-26	88	31	28.0	12.5	67	20	77	25
Winnipeg, MB	-21	-30	84	29	28.0	12.5	67	20	76	25

Source ASHRAE Fundamentals

Europe	Temperature (°C)	Humidity (%)
Athens	17.6	66
Berne	8.6	-
Geneva	9.2	-
Amsterdam	9.8	83
Innsbruck	8.4	-
London	9.9	79
Madrid	13.4	67
Moscow	3.6	79
Paris	10.3	77
Rome	15.4	72
Salzburg	8.2	-
Warsaw	7.3	82
Vienna	9.8	77
Zurich	8.2	-

Africa	Annual Temperature (°C)	Min. Temperature (°C)	Max. Temperature (°C)
Algeria, Skikda	17	12	25
Egypt, Cairo	21	16	27
Kenya, Mombasa	26	24	28
Libya	20	12	28
Morocco, Rabat	17	12	22
Nigeria, Port Harcourt	26	25	28
South Africa, Johannesburg	16	11	20
South Africa, Cape Town	17	12	21
Tunisia, Tunis	28	11	27
Zimbabwe, Harare	19	15	21

Artics	Annual Temperature (°C)	Min. Temperature (°C)	Max. Temperature (°C)
Antarctica, Ellsworth	-26	-37	-5
Arctic	-19	-35	-1

3.3 Usage tables

3.3.8.1 Average climate data

Asia	Annual Temperature (°C)	Min. Temperature (°C)	Max. Temperature (°C)
Afghanistan, Kabul	12	2	25
Azerbaijan, baku	13	6	25
Bangladesh	25	18	29
Brunei	27	23	31
China, Beijing	12	-3	26
China, Shanghai	16	4	28
India, Mumbai	27	23	30
India, Dehli	25	14	32
India,	28	24	32
Indonesia, Jakarta	27	23	31
Japan, Tokio	15	8	27
Malaysia, Kuala Lumpur	27	22	32
South Korea, Seoul	12	-2	25
Taiwan, Taipei	22	16	29
Thailand, Bangkok	28	21	30

Middle East	Annual Temperature (°C)	Min. Temperature (°C)	Max. Temperature (°C)
Bahrain	25	-	-
Gaza Strip	19	13	26
Iran, Tehran	17	1	31
Iran, Bandar-E-Abbas	27	17	34
Iraq, Baghdad	22	8	34
Israel, Jerusalem	16	7	23
Jordan, Ammam	17	7	25
Kuwait, Kuwait City	26	12	37
Lebanon, Beiroet	20	12	26
Oman, Muscat	28	21	35
Qatar, Doha	27	17	35
Saudi Arabia, Riyadh	26	14	36
Syria, Damascus	16	6	26
United Arab Emirates, Dubai	27	18	35
Yemen, Aden	29	26	32

Oceania	Annual Temperature (°C)	Min. Temperature (°C)	Max. Temperature (°C)
Australia, Melbourne	14	5	26
Australia, Adelaide	16	7	27
New Zealand, Nelson	12	5	23

South America	Annual Temperature (°C)	Min. Temperature (°C)	Max. Temperature (°C)
Argentina, Buenos Aires	16	10	23
Brazil, Rio de Janeiro	25	22	28
Colombia, Bogota	13	12	13
Ecuador, Tulcan	10	10	11
French Guiana	25	24	26
Guyana	27	22	32
Peru, curzco	12	3	20
Suriname, Paramaribo	27	22	33
Venezuela, Caracas	23	18	27
Venezuela, Barcelona	27	22	31

The Netherlands	Temperature (°C)	Humidity (%)
Amsterdam (Schiphol)	9.8	84
Arnhem (Deelen)	9.4	81
Den Haag	9.9	83
Den Helder	9.6	84
Eindhoven	9.9	81
Enschede	9.3	83
Groningen	9.0	86
Leeuwarden	9.2	85
Maastricht	9.8	82
Rotterdam	10	84
's Hertogenbosch	9.8	82
Soesterberg	9.6	81
Utrecht (De Bilt)	9.8	82
Viissingen	10.4	82

3.3 Usage tables

3.3.8.1 Average climate data

Belgium	Temperature (°C)	Humidity (%)
Antwerpen	9.6	-
Beauvechain	9.2	-
Botrange	5.7	-
Brussel	9.7	81
Chièvres	9.0	-
Dourbes	8.6	-
Elsenborn	5.7	-
Florennes	8.2	-
Gent	9.5	-
Kleine Brogel	9.0	-
Koksijde	9.4	-
Libramont	7.5	-
Spa	7.4	-
St-Hubert	6.8	-
Virton	8.7	-

France	Min. Temperature (°C)	Max. Temperature (°C)	Humidity (%)
Ajaccio	10.0	20.1	-
Bourges	0.8	15.8	-
Bordeaux	8.5	18.1	-
Dijon	6.4	15.1	-
La Rochelle	9.5	16.5	-
Lille	6.5	14.1	-
Lyon	7.5	16.4	-
Nice	12.0	19.2	-
Paris	8.6	15.5	77
Perpignan	11.0	19.8	-
Rennes	7.6	16.0	-
Strasbourg	6.1	14.8	-



Germany	Temperature (°C)	Humidity (%)
Berlin	9.1	77
Braunschweig	8.6	-
Bremerhaven	8.8	-
Dresden	9.3	74
Essen	9.5	82
Erfurt	8.0	-
Frankfurt/M.	10.1	76
Frankfurt a.O.	8.2	-
Giessen	9.0	-
Görlitz	8.3	-
Halle	9.1	76
Hamburg	8.4	80
Magdeburg	9.1	-
Mannheim	10.2	-
Munich	8.1	-
Nuremberg	8.5	-
Plauen	7.2	-
Regensburg	8.1	-
Rostock	7.8	-
Stuttgart	8.6	-
Trier	9.1	-



3.3 Usage tables

3.3.8.2 Wind speed

Beaufort scale	Wind speed (m/s)	Wind speed mph	Definition
0	0 - 0.2	0 - 1	Calm
1	0.3 - 1.5	1 - 3	Light air
2	1.6 - 3.3	4 - 7	Light breeze
3	3.4 - 5.4	8 - 12	Gentle breeze
4	5.5 - 7.9	13 - 17	Moderate breeze
5	8.0 - 10.7	18 - 24	Fresh breeze
6	10.8 - 13.8	25 - 30	Strong breeze
7	13.9 - 17.1	31 - 38	Moderate gale (strong wind)
8	17.2 - 20.7	39 - 46	Fresh gale (strong wind)
9	20.8 - 24.4	47 - 54	Strong gale (strong wind)
10	24.5 - 28.4	55 - 63	Whole gale / storm
11	28.5 - 32.6	64 - 73	Violent storm
0.12	> 32.7	> 74	Hurricane

Generally speaking, the wind speed is also dependent on the height and location (inland, coastal). In order to calculate the insulation thickness, the following wind speeds are generally used:

- Inside: 1.1 mph (0.5 m/s)
- Outside in protected conditions: 2.2 mph (1 m/s)
- Outside: 11 mph (5 m/s)
- Outside in windy conditions (e.g. near to coast): 22 mph (10 m/s)

3.3 Usage tables

3.3.9 Guidelines average velocities in pipe work

Type of fluid / piping	Velocity (m/s)	(ft/s)	
Steam piping	Saturated steam	20 to 35	650 to 1150
	LP(low-pressure) steam	30	1000
	MP(media-pressure) steam	40	1300
	HP(high-pressure) steam	60	2000
(Hot) water supply	Feed	2 to 3	65 to 100
	Return	1	33
Oil	Low viscosity	1.5	50
	High viscosity	0.5	16
District heating	Average	2	65
Central heating (non residential buildings)	Main feed stock	0.5	16

3.3.10 Pipe diameter

Many different standards exist in relation to pipe sizes, the distribution of which varies according to the sector of industry and geographical area. The denotation of the pipe size generally comprises two numbers; one, which indicates the external diameter or nominal diameter, and a further number that indicates the wall thickness.

- In North America and Great Britain, high-pressure pipe systems are generally classified by means of the Nominal Pipe Size (NPS) System in Inches. The pipe sizes are documented in a series of standards. In the USA, these standards include API 5L, ANSI/ASME B36.10M and in Great Britain BS 1600 and BS 1387. As a rule, the pipe wall thickness is the fixed variable and the internal diameter is permitted to vary.
- In Europe, the same internal diameter and wall strengths as used in the Nominal Pipe Size

system are used for high-pressure pipe systems, however they are conveyed in a metric nominal diameter instead in inches as given in the NPS system. For nominal pipe sizes above 14, the nominal diameter (DN) size corresponds to the NPS size multiplied by 25 (not 25.4). These pipes are documented in the EN 10255 standard (formerly DIN 2448 and BS 1387) and in the ISO 65 standard and are often denoted as DIN- or ISO-pipes.

In order to ensure a joint-free laying of the insulation, it is important that you know the actual external diameter of the pipe, as there are an immense number of pipe dimensions.

The following table provides a general overview of common pipe diameters with a comparison between the inches and DN size.

3.3 Usage tables

3.3.10 Pipe diameter

Nominal Pipe Size (NPS in inch)	Nominal diameter (DN/Metric)	Outer diameter (inch)	Outer diameter (mm)
1/8	DN 6	0.406	10.3
1/4	DN 8	0.539	13.7
3/8	DN 10	0.673	17.1
1/2	DN 15	0.840	21.3
3/4	DN 20	1.050	26.7
1	DN 25	1.315	33.4
1 ¼	DN 32	1.660	42.2
1 ½	DN 40	1.900	48.3
2	DN 50	2.375	60.3
2 ½	DN 65	2.875	73
3	DN 80	3.5	88.9
3 ½	DN 90	4	101.6
4	DN 100	4.5	114.3
4 ½	DN 115	5	127
5	DN 125	5.563	141.3
6	DN 150	6.625	168.3
8	DN 200	8.625	219.1
10	DN 250	10.75	273.1
12	DN 300	12.75	323.9
14	DN 350	14	355.6
16	DN 400	16	406.4
18	DN 450	18	457.2
20	DN 500	20	508
22	DN 550	22	558.8
24	DN 600	24	609.6
26	DN 650	26	660.4
28	DN 700	28	711.2
30	DN 750	30	762
32	DN 800	32	812.8
34	DN 850	34	863.6
36	DN 900	36	914

3.3.11 Fire curve: ISO and hydrocarbon

ISO fire curve

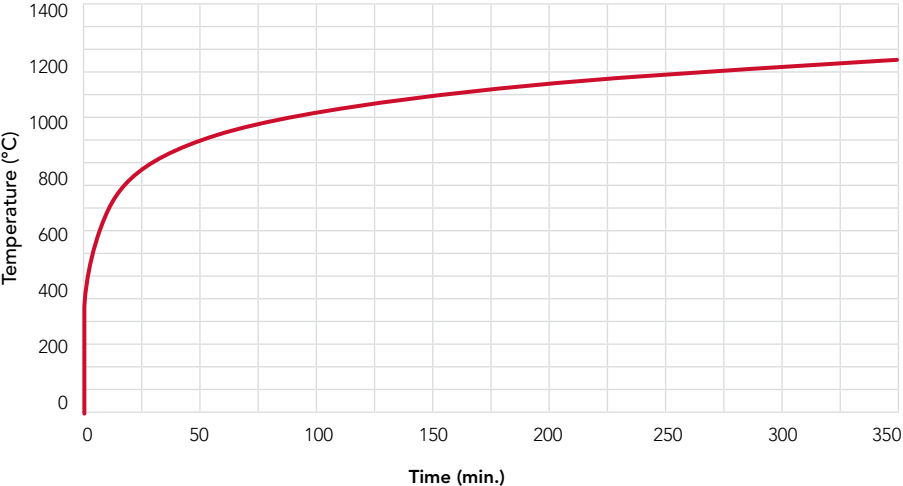

Hydrocarbon fire curve

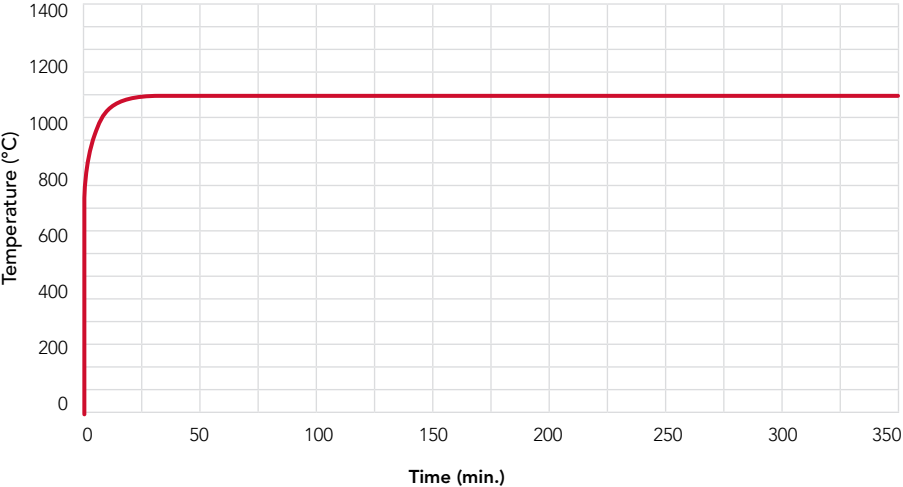



4

Products

ProRox®

Industrial
insulation

ProRox®

High temperature industrial insulation solutions

1 ProRox wired mats for high temperature insulation for pipes



2 ProRox flexible mats and slabs (board) for thermal insulation of vessels and columns



3 ProRox wired mats and slabs (board) for high temperature insulation of crackers and boilers

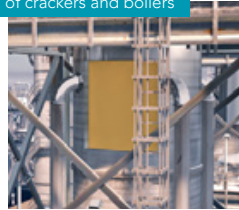

4 ProRox pipe section for thermal and acoustical insulation of pipes



5 ProRox compression resistant slabs (board) for tank roof insulation



6 ProRox flexible mats and slabs (board) for insulation of tank walls



7 ProRox granulate for insulation of cold boxes

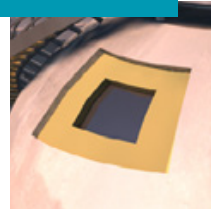

8 ProRox load bearing mats for thermal and acoustical insulation for pipes

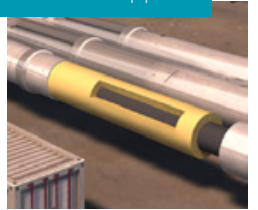

4. Products

Through the ProRox range, ROCKWOOL Technical Insulation offers a wide assortment of high quality stone wool insulation products for sustainable insulation of industrial and power

generation plants. Each product is developed with a specific field of application (e.g. pipework, boilers, vessels, columns and storage tanks) in mind.

ROCKWOOL Technical Insulation products and solutions for industrial applications.

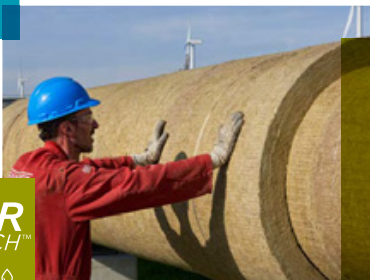

ProRox mandrel wound pipe sections with WR-Tech:
ProRox pipe sections with WR-Tech are high quality and durable insulation materials that are pre-formed and supplied with split and hinged sections for easy snap-on assembly, which are suitable for thermal and acoustic insulation of industrial pipework. The sections are produced with an innovative water repellent binder called WR-Tech to mitigate the risk of corrosion under insulation. ProRox pipe sections with WR-Tech are available in a wide range of diameters and thicknesses. The use of pipe sections ensures optimal insulation.

with **WR TECH™**
PATENT PENDING



ProRox wired mats:
ProRox wired mats are lightly bonded stone wool mat stitched on galvanised wired mesh with galvanised wire. Part of our wired mat range are produced with an innovative water repellent binder, known as WR-Tech, to mitigate the risk of corrosion under insulation (CUI). Wired mats are available in a wide range of densities and thicknesses up to 120 mm. Stainless steel wired mesh and wire are available upon request. Wired mats are suitable for thermal and acoustic insulation of industrial pipework, boiler walls, furnaces and industrial smoke exhaust ducts. The use of ProRox wired mats provides both flexibility and quality of insulation.



ProRox slabs (board):
ProRox stone wool slabs (board) are available in a wide range of densities and thicknesses for thermal and acoustic insulation of flat surfaces. Slabs (board) are offered in both rigid and semi-rigid form (offering more flexibility), and can be used for a variety of purposes, such as fabrication or mechanical load resistance.

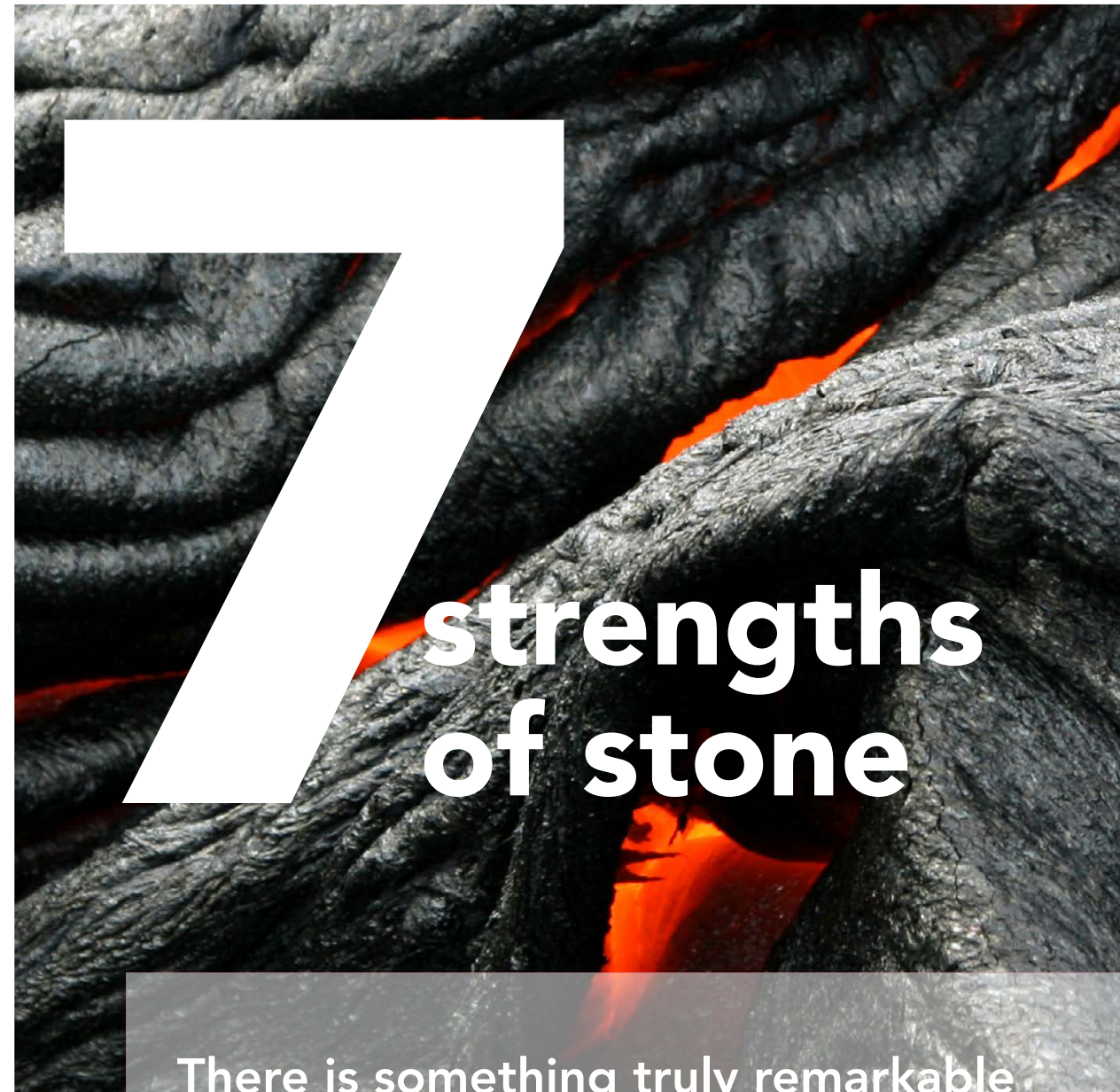

There is something truly remarkable about the natural power of stone



Fire-resilience

Withstands temperatures above 1800°F (1000°C).



Thermal properties

Saves energy and reduces thermal losses to an absolute minimum by maintaining optimum temperatures also during transfer or storage.



Acoustics capabilities

Reduces noise.



Robustness

Longer-lasting performance and robustness with easier installation.



Water properties

When engineered to repel water, stone wool can defend valuable industrial equipment from CUI.



Aesthetics

Matches performance with aesthetics: see our sister brands Rockfon & Rockpanel.



Circularity

Reusable and recyclable material.

ProRox insulation

Our ProRox products combine most of the 7 strengths of stone with one ambitious goal in mind: to minimise the human impact on our surroundings, whilst maximising the safety and wellbeing of all the people interacting with our products.

ROCKWOOL stone wool is made from materials that nature itself produces in abundant quantities, one of the earth's inexhaustible resources - volcanic rock. In addition, stone wool withstands temperatures above 1800°F (1000°C), making it highly fire resilient. This means our ProRox product line improves the fire resistance of any technical installation.

Moreover, thanks to its thermal properties the heat stays in the pipework, tanks, columns, vessels, chimneys and boilers. Energy loss and CO₂ emissions are reduced to the minimum, and people are protected from burns (by thermal exposure or contact with hot surfaces). And talking about protection: stone wool has significant acoustic capabilities, keeping the noise down in any industrial environment.

At the same time, stone wool absorb less water and dries faster and therefore the insulation maintains its optimal performance, mitigating the risk of CUI (corrosion under insulation). Discover all the strengths of stone wool at rti.rockwool.com.

4. Products

4.1 Products: Europe, Middle-East & Africa

The main characteristic of ProRox products is their excellent thermal insulation capacity. Next to this, they of course also comply with the most stringent requirements on fire resistance and acoustic insulation. Below you will get an overview of the

most important ProRox products which are available in Europe, Middle-East and Africa. More information can be found on our website rti.rockwool.com.

Product Group	Product name	Description
Pipe sections	ProRox PS 960	Mandrel wound pipe section with WR-Tech
	ProRox PS 970	Mandrel wound pipe section with WR-Tech
Wired mats	ProRox WM 951	Wired mat with WR-Tech
	ProRox WM 961	Heavy duty wired mat with WR-Tech
	ProRox WM 950	Wired mat
	ProRox WM 960	Heavy duty wired mat
Load bearings mats	ProRox MA 520 ALU	Load bearing mat (wrap)
Slabs	ProRox SL 930	Semi-rigid slab (board)
	ProRox SL 950	Rigid slab (board)
	ProRox SL 960	High temperature slab (board)
	ProRox SL 980	Hard and rigid slab (board)
	ProRox SL 560	Compression resistant slab (board)
Loose fill	ProRox LF 970	Loose fill
Granulate	ProRox GR 903	Granulated loose fill

For more detailed information such as: product performance, certification and standards, see our website: rti.rockwool.com

Pipe sections



Stretch wrapped
(large diameters)



Boxed
(small diameters)

Mats (wrap)

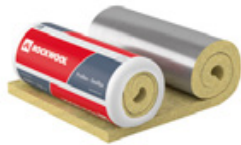

Wired mats



Slabs (board)



General pallet



SL 920 pallet

Granulates & loose wool



4.1 Products: Europe, Middle-East & Africa

ProRox PS 960

Mandrel wound pipe section
with WR-Tech



CE



PATENT
PENDING

Product description

ProRox PS 960 is a mandrel wound stone wool insulation pipe section. The pipe sections are produced with an innovative water repellent binder, known as WR-Tech™, to mitigate the risk of corrosion under insulation (CUI). WR-Tech ensures our stone wool maintains its superior water repellency even at elevated operating temperatures within the CUI range, while preserving its excellent thermal performance in use. Reinforced aluminium foil facing is available upon request.

Application

The highly-durable insulation sections come split and hinged for easy snap-on assembly and are especially suitable for thermal and acoustic insulation of industrial pipework, marine and offshore installations.

ProRox PS 970

Mandrel wound pipe section
with WR-Tech



CE



PATENT
PENDING

Product description

ProRox PS 970 is a mandrel wound stone wool insulation pipe section. The pipe sections are produced with an innovative water repellent binder, known as WR-Tech™, to mitigate the risk of corrosion under insulation (CUI). WR-Tech ensures our stone wool maintains its superior water repellency even at elevated operating temperatures within the CUI range, while preserving its excellent thermal performance in use. Reinforced aluminium foil facing is available upon request.

Application

The highly-durable insulation sections come split and hinged for easy snap-on assembly and are especially suitable for the thermal and acoustic insulation of high-temperature industrial pipework subjected to mechanical loads.

For more detailed information such as: product performance, certification and standards, see our website: rti.rockwool.com

ProRox WM 951

Wired mat
with WR-Tech



CE

PATENT
PENDING



Product description

ProRox WM 951 is a lightly bonded stone wool insulation mat stitched on galvanized wire mesh with galvanized wire. Stainless steel mesh, stainless steel binding wire and/or reinforced aluminium foil facing are available upon request. The wired mats are produced with an innovative water repellent binder, known as WR-Tech™, to mitigate the risk of corrosion under insulation (CUI). WR-Tech ensures our stone wool maintains its superior water repellency even at elevated operating temperatures within the CUI range, while preserving its excellent thermal performance in use.

Application

The wired mat is suitable for the thermal and acoustic insulation of industrial installations exposed to the environment, such as outdoor industrial pipework and equipment at petrochemical plants and refineries.

ProRox WM 961

Wired mat
with WR-Tech



CE

PATENT
PENDING



Product description

ProRox WM 961 is a lightly bonded heavy duty stone wool insulation mat stitched on galvanized wired mesh with galvanized wire. Stainless steel mesh, stainless steel binding wire and/or reinforced aluminium foil facing are available upon request. The wired mats are produced with an innovative water repellent binder, known as WR-Tech™, to mitigate the risk of corrosion under insulation (CUI). WR-Tech ensures our stone wool maintains its superior water repellency even at elevated operating temperatures within the CUI range, while preserving its excellent thermal performance in use.

Application

The wired mat is suitable for the thermal and acoustic insulation of industrial installations exposed to the environment, such as outdoor industrial pipework, reactors and furnaces at petrochemical plants and refineries.

4.1 Products: Europe, Middle-East & Africa

ProRox WM 950

Wired mat



Product description

ProRox WM 950 is a lightly bonded stone wool insulation mat stitched on galvanized wire mesh with galvanized wire. Stainless steel mesh, stainless steel binding wire and/or reinforced aluminium foil facing are available upon request.

Application

The wired mat is suitable for the thermal and acoustic insulation of industrial installations exposed to the environment when high-temperature resistance is demanded, such as industrial pipework, reactors and hot columns at petrochemical plants and refineries.

CE

ProRox WM 960

Wired mat



Product description

ProRox WM 960 is a lightly bonded heavy duty stone wool insulation mat stitched on galvanized wired mesh with galvanized wire. Stainless steel mesh, stainless steel binding wire and/or reinforced aluminium foil facing are available upon request.

Application

The wired mat is especially suitable for the thermal insulation of industrial applications when high-temperature resistance is demanded, such as high-pressure steam pipes, reactors and furnaces.

CE

For more detailed information such as: product performance, certification and standards, see our website: rti.rockwool.com

ProRox MA 520 ALU



CE

Load bearing mat (wrap)

Product description

ProRox MA 520 ALU is a compression-resistant, flexible stone wool insulation mat (wrap) with a predominantly vertical fiber structure coated on one side with a reinforced aluminium foil.

Application

The mat (wrap) is suitable for the thermal and acoustic insulation of industrial applications up to intermediate temperatures, such as large diameter piping, vessels, ducts and equipment.

4.1 Products: Europe, Middle-East & Africa

ProRox SL 930

Semi-rigid slab (board)



Product description

ProRox SL 930 is a semi-rigid stone wool insulation slab (board). Reinforced aluminium foil facing is available upon request.

Application

The slab (board) is suitable for the thermal and acoustic insulation of horizontal and vertical applications requiring a stable insulation product, such as tank walls, vessels and columns.

CE

ProRox SL 950

Rigid slab (board)



Product description

ProRox SL 950 is a rigid stone wool insulation slab (board).

Application

The slab (board) is suitable for the thermal and acoustic insulation of high-temperature industrial applications, such as tank walls, vessels and columns.

CE

For more detailed information such as: product performance, certification and standards, see our website: rti.rockwool.com

ProRox SL 960



CE

High-temperature slab (board)

Product description

ProRox SL 960 is a strong, rigid stone wool insulation slab (board).

Application

The slab (board) is suitable for the thermal and acoustic insulation of high-temperature industrial applications, such as boilers, vessels and columns.

ProRox SL 980



CE

Hard and rigid slab (board)

Product description

ProRox SL 980 is a hard, rigid stone wool insulation slab (board).

Application

The slab (board) is suitable for the thermal and acoustic insulation of constructions where higher demands are made on the temperature resistance and mechanical loads of the insulation.

4.1 Products: Europe, Middle-East & Africa

ProRox SL 560



CE

Compression resistant slab (board)

Product description

ProRox SL 560 is a pressure-resistant rigid stone wool insulation slab (board).

Application

The slab (board) is suitable for the thermal and acoustic insulation of high-temperature industrial applications exposed to foot traffic or constructions subjected to heavy mechanical loads, such as tank roofs.

ProRox LF 970

Loose fill



CE

Product description

ProRox LF 970 is a lightly bonded loose fill, impregnated stone wool insulation product.

Application

This product is especially suitable for the thermal and acoustic insulation of voids, joints and irregularly formed constructions.

ProRox GR 903

Granulated loose fill



CE

Product description

ProRox GR 903 is a stone wool insulation product in granulate form.

Application

The product is especially suitable for the thermal insulation of cold boxes and air separation plants.

4. Products

4.2 Products: North America

The main characteristic of ProRox products is their excellent thermal insulation capacity. Next to this, they of course also comply with the most stringent requirements on fire resistance and acoustic

insulation. Below you will get an overview of the most important ProRox products which are available in North America. More information can be found on our website rti.rockwool.com.

Product Group	Product name	Description
Pipe sections	ProRox PS 960	Mandrel wound pipe section with WR-Tech
	PRoRox PS 980	Mandrel wound pipe section with WR-Tech
Load bearing mats	ProRox MA 960 ^{NA}	Load bearing mats (wrap)
Slabs	ProRox SL 930 ^{NA}	Semi-rigid slab (board)
	ProRox SL 940 ^{NA}	Rigid slab (board)
	ProRox SL 960 ^{NA}	Strong and rigid slab (board)
	ProRox SL 540 ^{NA}	Pressure resistant rigid slab (board)
	ProRox SL 560 ^{NA}	Pressure resistant rigid slab (board)
	ProRox SL 590 ^{NA}	Pressure resistant rigid slab (board)

For more detailed information such as: product performance, certification and standards, see our website: rti.rockwool.com

ProRox PS 960



PATENT
PENDING



Mandrel wound pipe section with WR-Tech

Product description

ProRox PS 960 is a mandrel wound stone wool insulation pipe section. The pipe sections are produced with an innovative water repellent binder, known as WR-Tech™, to mitigate the risk of corrosion under insulation (CUI). WR-Tech ensures our stone wool maintains its superior water repellency even at elevated operating temperatures within the CUI range, while preserving its excellent thermal performance in use.

Application

The highly-durable insulation sections come split and hinged for easy snap-on assembly and are especially suitable for thermal and acoustic insulation of industrial pipework, marine and offshore installations.

ProRox PS 980



PATENT
PENDING



Mandrel wound pipe section with WR-Tech

Product description

ProRox PS 980 is a high compression-resistant mandrel wound stone wool insulation pipe section. The pipe sections are produced with an innovative water repellent binder, known as WR-Tech™, to mitigate the risk of corrosion under insulation (CUI). WR-Tech ensures our stone wool maintains its superior water repellency even at elevated operating temperatures within the CUI range, while preserving its excellent thermal performance in use.

Application

The highly-durable insulation sections come split and hinged for easy snap-on assembly and are especially suitable for the thermal and acoustic insulation of high-temperature industrial pipework subjected to mechanical loads.

4.2 Products: North America

ProRox MA 960^{NA}



Load bearing mats (wrap)

Product description

ProRox MA 960^{NA} is a rolled stone wool insulation mat (wrap) faced as standard with black fibrous scrim. Reinforced aluminium foil facing is available upon request.

Application

The mat (wrap) is suitable for the thermal and acoustic insulation of high-temperature industrial applications subjected to light mechanical loads, such as large diameter piping, vessels, ducts and equipment.

ProRox SL 930^{NA}



Semi-rigid slab (board)

Product description

ProRox SL 930^{NA} is a semi-rigid stone wool insulation slab (board).

Application

The slab (board) is suitable for the thermal and acoustic insulation of horizontal and vertical applications requiring a stable insulation product, such as tank walls, vessels and columns.

For more detailed information such as: product performance, certification and standards, see our website: rti.rockwool.com

ProRox SL 940^{NA}

Rigid slab (board)



Product description

ProRox SL 940^{NA} is a rigid stone wool insulation slab (board).

Application

The slab (board) is suitable for the thermal and acoustic insulation of high-temperature industrial applications, such as tank walls, vessels and columns.

ProRox SL 960^{NA}

Strong and rigid slab (board)



Product description

ProRox SL 960^{NA} is a strong, rigid stone wool insulation slab (board).

Application

The slab (board) is suitable for the thermal and acoustic insulation of high-temperature industrial applications subjected to light mechanical loads, such as tanks, boilers, vessels and columns.

4.2 Products: North America

ProRox SL 540^{NA}



Pressure resistant rigid slab (board)

Product description

ProRox SL 540^{NA} is a pressure-resistant rigid stone wool insulation slab (board).

Application

The slab (board) is suitable for the thermal and acoustic insulation of high-temperature industrial applications subjected to light mechanical loads, such as tanks and columns.

ProRox SL 560^{NA}



Pressure resistant rigid slab (board)

Product description

ProRox SL 560^{NA} is a pressure-resistant rigid stone wool insulation slab (board).

Application

The slab (board) is suitable for the thermal and acoustic insulation of high-temperature industrial applications subjected to moderate mechanical loads, such as tanks and columns.

For more detailed information such as: product performance, certification and standards, see our website: rti.rockwool.com

ProRox SL 590^{NA}



Pressure resistant rigid slab (board)

Product description

ProRox SL 590^{NA} is a pressure-resistant rigid stone wool insulation slab (board).

Application

The slab (board) is suitable for the thermal and acoustic insulation of high-temperature industrial applications exposed to foot traffic or constructions subjected to heavy mechanical loads, such as tank roofs.

ROCKWOOL Technical Insulation

ROCKWOOL Technical Insulation is part of the ROCKWOOL Group and is offering advanced technical insulation solutions for the process industry as well as marine & offshore.

At the ROCKWOOL Group, we are committed to enriching the lives of everyone who comes into contact with our solutions. Our expertise is perfectly suited to tackle many of today's biggest sustainability and development challenges, from energy consumption and noise pollution to fire resilience, water scarcity and flooding. Our range of products reflects the diversity of the world's needs, while supporting our stakeholders in reducing their own carbon footprint.

Stone wool is a versatile material and forms the basis of all our businesses. With approx. 11,700 passionate colleagues in 39 countries, we are the world leader in stone wool solutions, from building insulation to acoustic ceilings, external cladding systems to horticultural solutions, engineered fibres for industrial use to insulation for the process industry and marine & offshore.

All explanations correspond to our current range of knowledge and are therefore up-to-date. The examples of use outlined in this document serve only to provide a better description and do not take special circumstances of specific cases into account. ROCKWOOL Technical Insulation places great value upon continuous development of products, to the extent that we too continuously work to improve our products without prior notice. We therefore recommend that you use the most recent edition of our publications, as our wealth of experience and knowledge is always growing. Should you require related information for your specific application or have any technical queries, please contact our sales department or visit our website rti.rockwool.com.

ROCKWOOL Technical Insulation

ROXUL INC.
8024 Esquesing Line,
Milton, ON L9T 6W3,
Canada
Tel. 1 800 265 68788
rti.rockwool.com

ROCKWOOL BV
Delfstoffenweg 2
6045 JH Roermond
The Netherlands
Tel. +31 (0) 475 35 36 18
Fax +31 (0) 475 35 36 01
E-mail: info-rti@rockwool.nl
rti.rockwool.com



ROCKWOOL® Technical Insulation, ROCKWOOL®, SeaRox® and ProRox® are registered trademarks of ROCKWOOL International A/S and cannot be used without a prior written consent. ROCKWOOL Technical Insulation reserves the right to change the information in this brochure without prior notice.